

EMI/EMC FILTER

RoHS

TB6-B SERIES



Features

- 3-Phase filters(Potted with epoxy resin)
- Good shield effect by using metal case
- Excellent filtering characteristics for both differential mode and common mode
- Safety: cCSAus, SEMKO+ENEC(Except for TB6-B300***), KC, CE/
TB6-B***LASH only: cCSAus, SEMKO+ENEC, CE

Applications

- Battery, ESS equipments
- Electric vehicle charger
- Industrial equipment such as CNC machine, inverter, converter, telecommunication equipment, FA equipment, elevator, etc.

Specifications

Model	Rated Voltage	Rated Current	Voltage Drop	Operating Temperature
TB6-B006NBDC	254/440 (KC, SEMKO+ENEC, CE), 277/480 (cCSAus) (50/60Hz)	6A	1.0 V	-25°C ~ +100°C Including temperature rise Derating Curve
TB6-B010NBDC		10A		
TB6-B016NBDC		16A		
TB6-B020NBDC		20A		
TB6-B030NBDC		30A		
TB6-B040As		40A		
TB6-B060LAs		60A		
TB6-B080LAs		80A		
TB6-B100LAs		100A		
TB6-B150LAs		150A		
TB6-B200LBs		200A		
TB6-B250LBs		250A		
TB6-B300LBs		300A		
TB6-B400LBs		400A		

※ Many variations in X and Y capacitor value are available with approvals.
 TB6-B*****s : Used for CNC Machines
 TB6-B010~B030N(L)BDC : *Used for Servo Driver System
 For the details, consult with local agent.

Note : Test Voltage: 3000VDC for 1 minute, line to ground
 Insulation Resistance: 300MΩ minimum at 100VDC, line to ground
 Weight: 1.3Kg for TB6-B006**/B010**/B016**/B020**/B030**
 2.2Kg for TB6-B040A*
 4.5Kg for TB6-B060LA*/B080LA*
 4.3Kg for TB6-B100LA*
 8.2/8.5Kg for TB6-B200LB*/B250LB*
 12.2Kg for TB6-B400LB*

Model Number Construction

TB6	B	060	LA	S
Series name : 3 Phase, 3Line Filter	Input/Output B:Terminal Block	Rated Current 060 = 60 A 080 = 80 A 100 = 100 A 150 = 150 A	Circuit Stage LA = 1 Stage (Permeability of Core : 7K) LB = 2 Stage (Permeability of Core : 7K) NB = 2 Stage Permeability of Core : 10K)	Suffix S= Standard 1= X-Capacitor 3.3uF, Y-Capacitor 10,000pF DC= X-Capacitor 2.2uF, Y-Capacitor 10,000pF

Shapes and Dimensions

TB6-B006N(L)B**~TB6-B030NB**

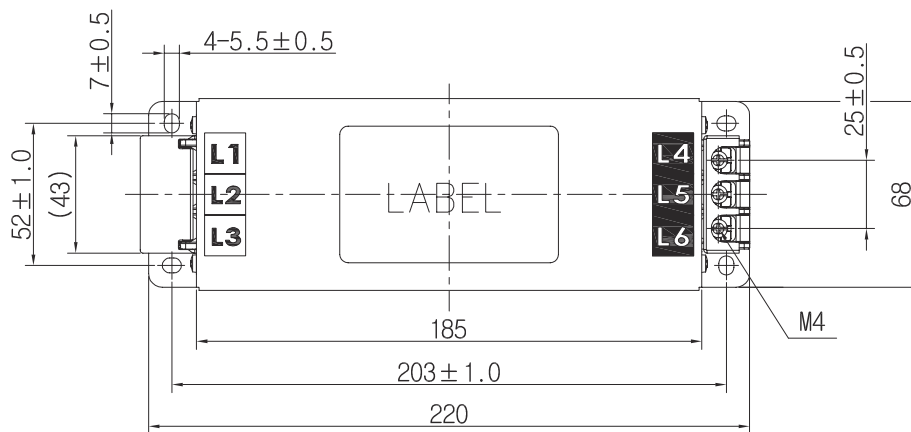

- * Unit : mm
- * General tolerance : ±3.0
- * Metal Case

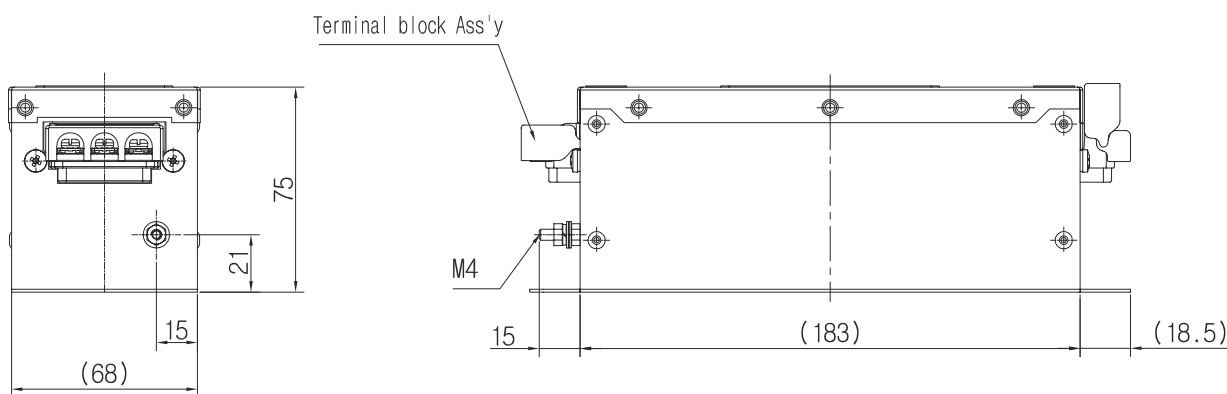

TB6-B040LA*

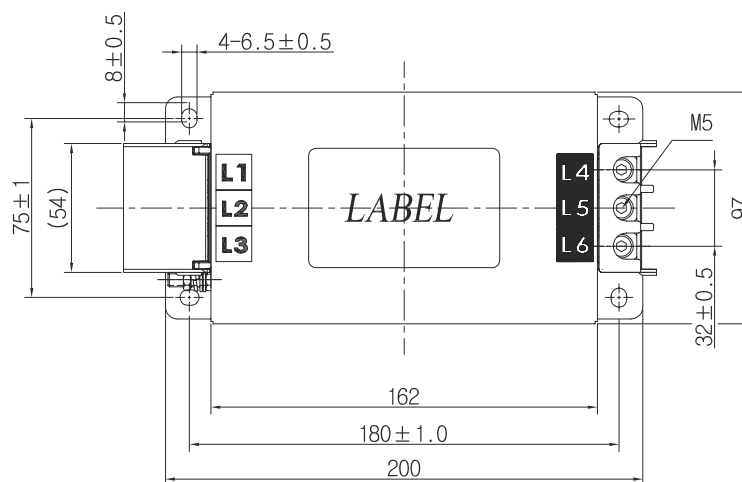

- * Unit : mm
- * General tolerance : ±3.0
- * Metal Case

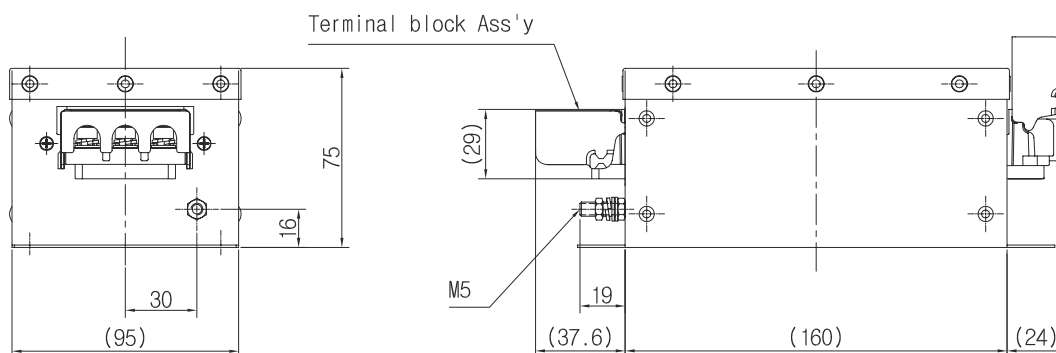

Shapes and Dimensions

TB6-B060LA* & TB6-B080LA*

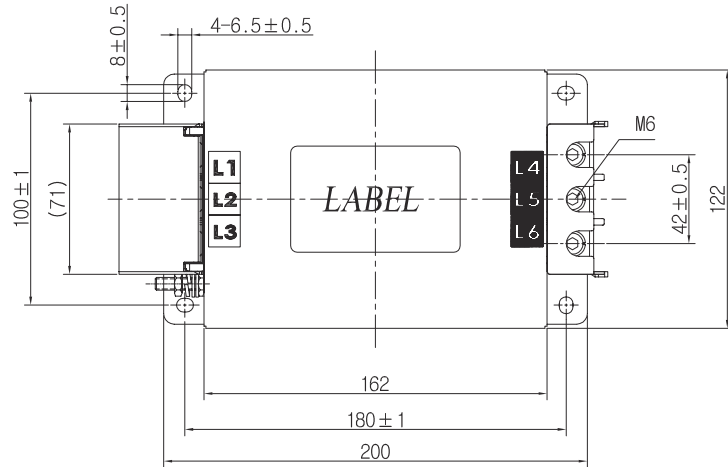

- * Unit : mm
- * General tolerance : ± 3.0
- * Metal Case

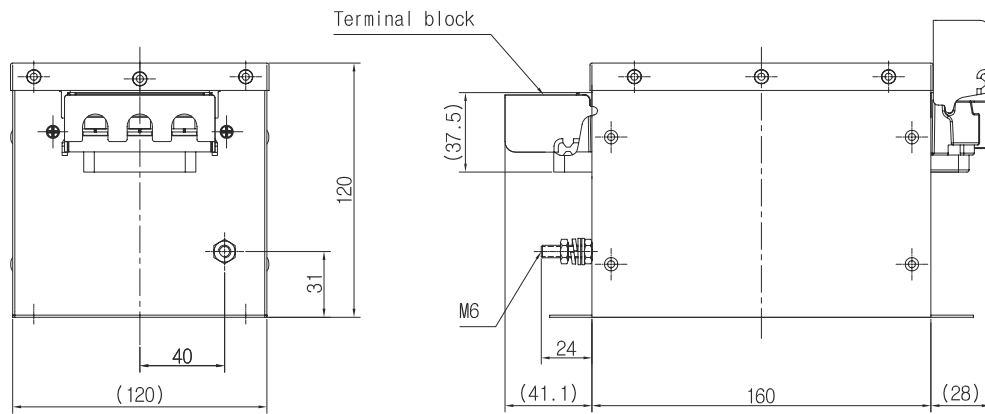

TB6-B100LA*

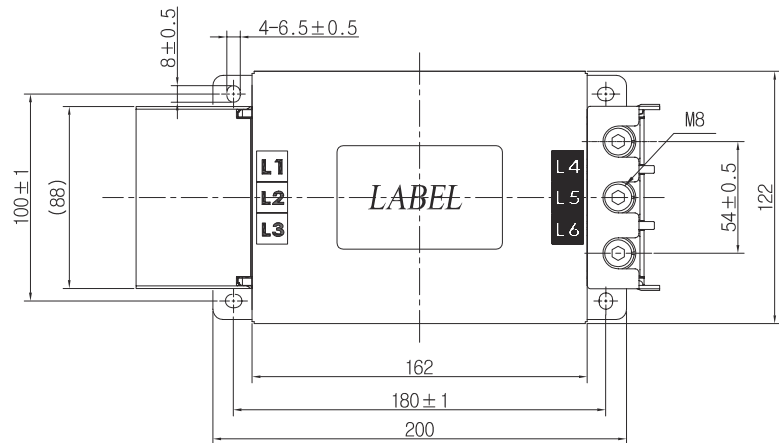

- * Unit : mm
- * General tolerance : ± 3.0
- * Metal Case

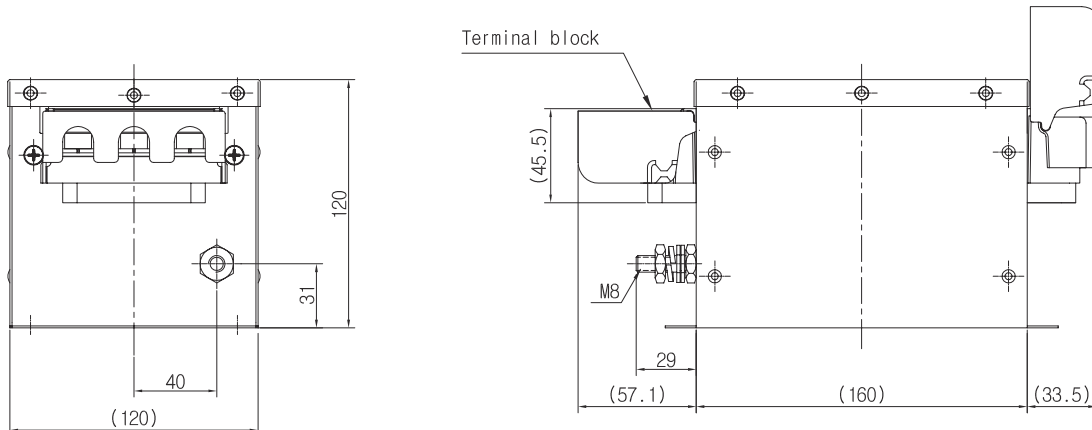

Shapes and Dimensions

TB6-B150LA*

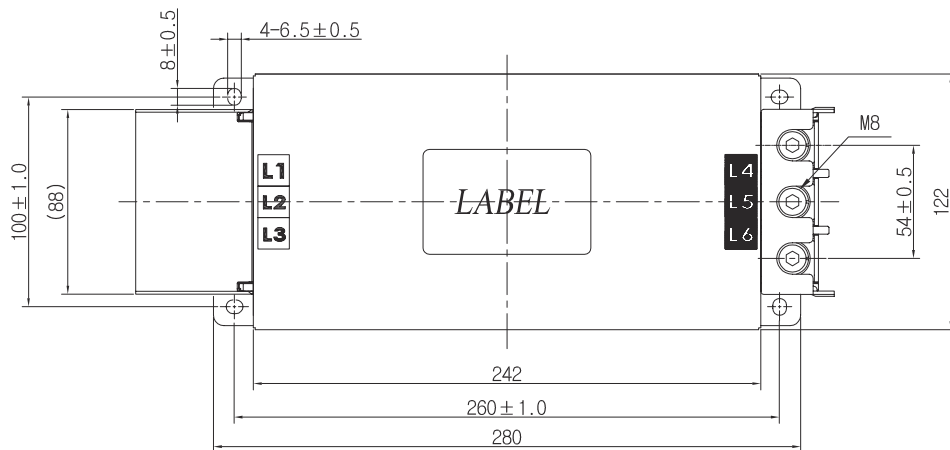

- * Unit : mm
- * General tolerance : ± 3.0
- * Metal Case

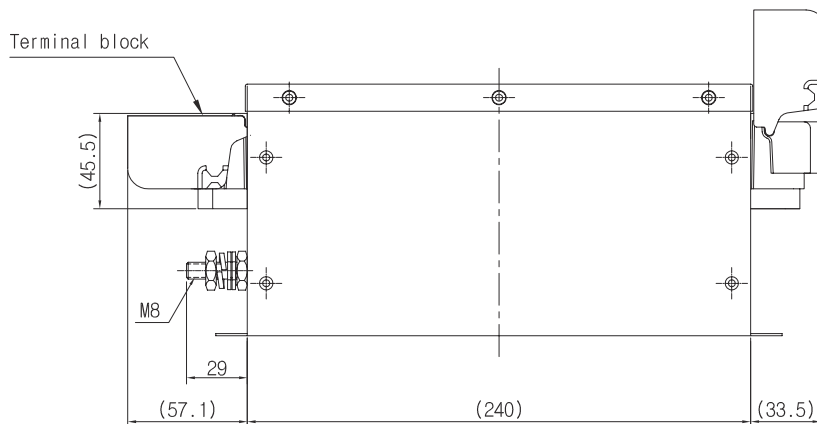
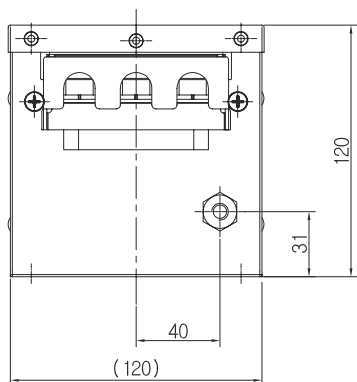

TB6-B200LB* & TB6-B250LB*

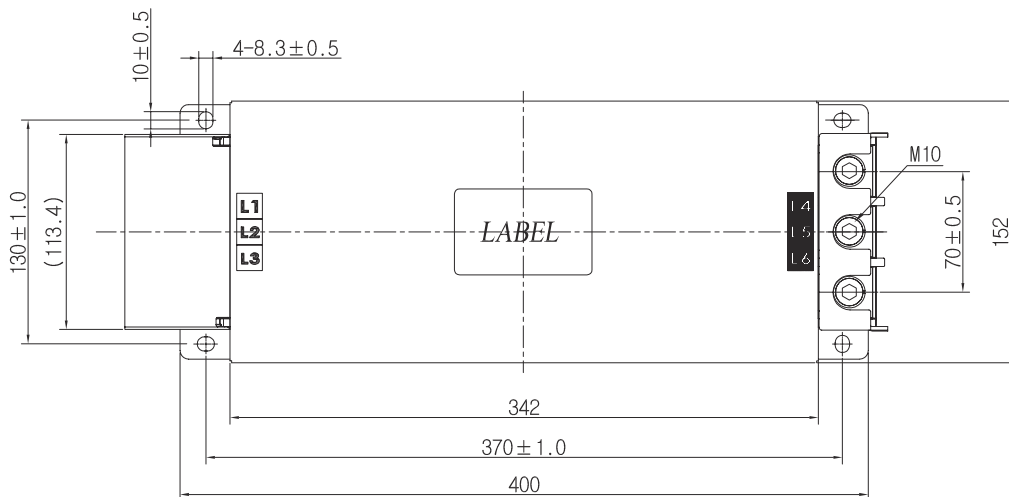

- * Unit : mm
- * General tolerance : ± 3.0
- * Metal Case

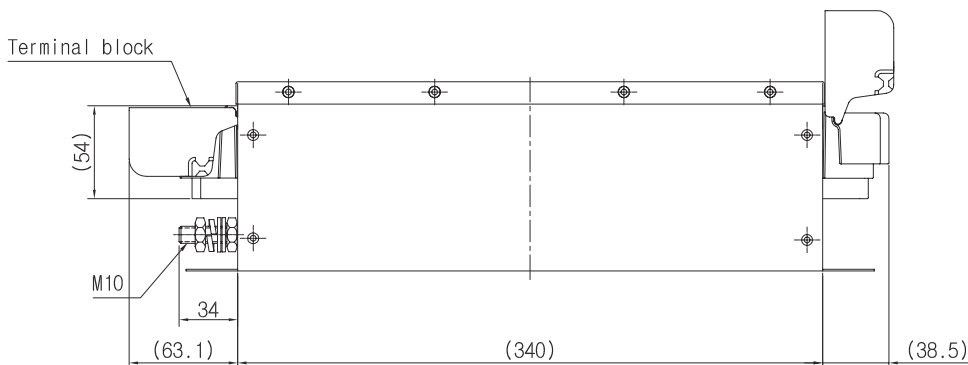
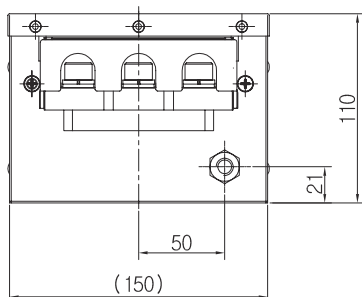

Shapes and Dimensions

TB6-B400LB*

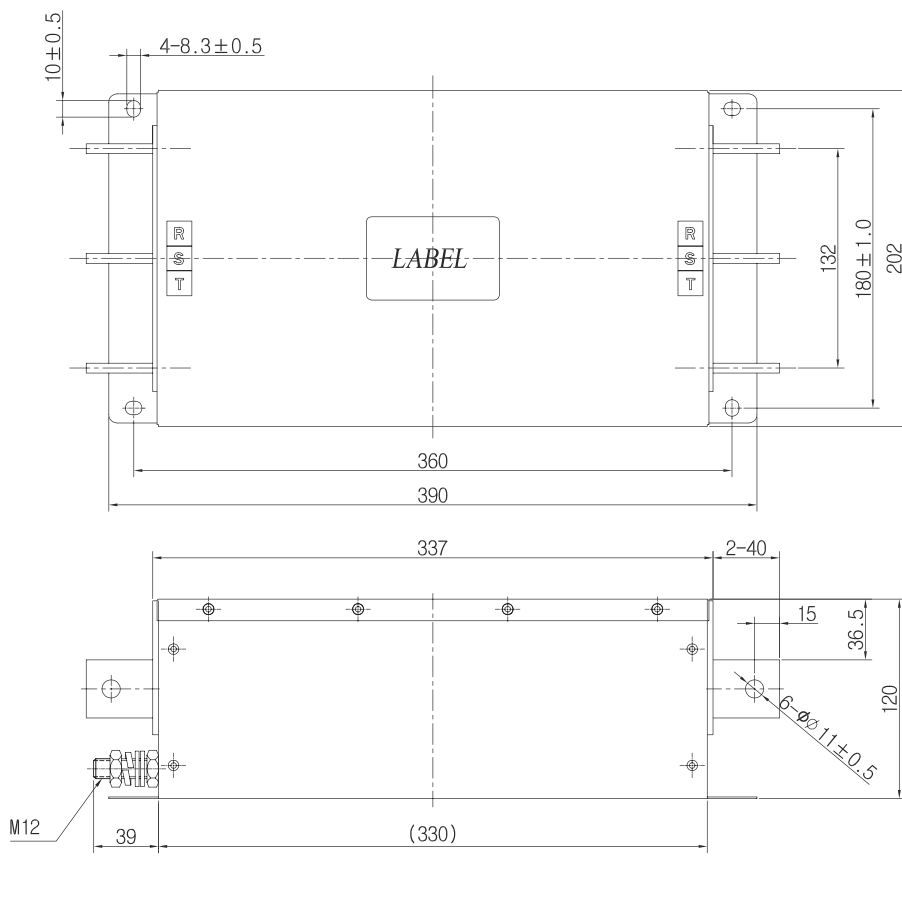

- * Unit : mm
- * General tolerance : ± 5.0
- * Metal Case

Attenuation Measuring Method

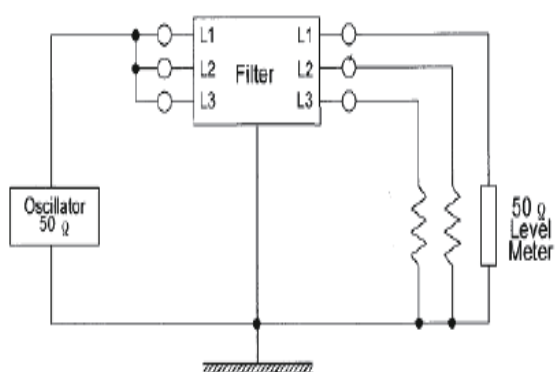

Common mode

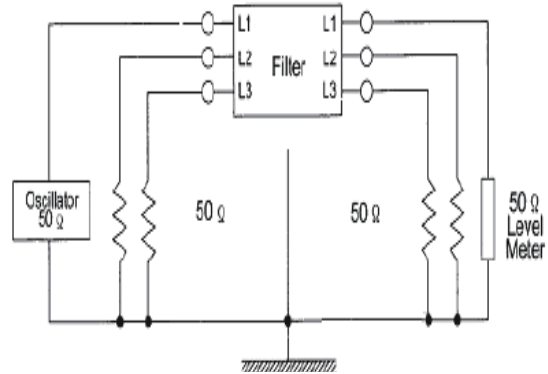

Differential mode

Circuit Diagram

TB6-B006NBDC~TB6-B030NBDC

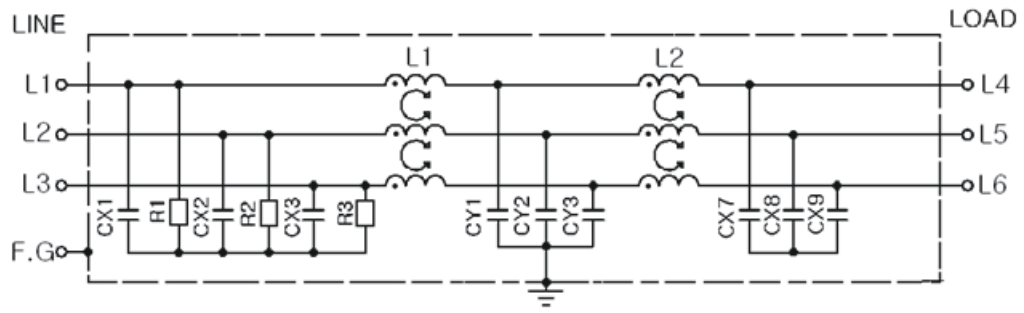

TB6-B040A*

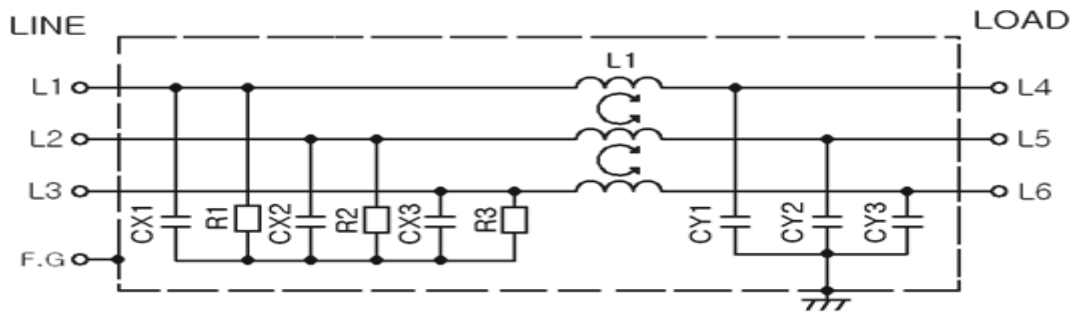

TB6-B060LA** ~ TB6-B150LA**

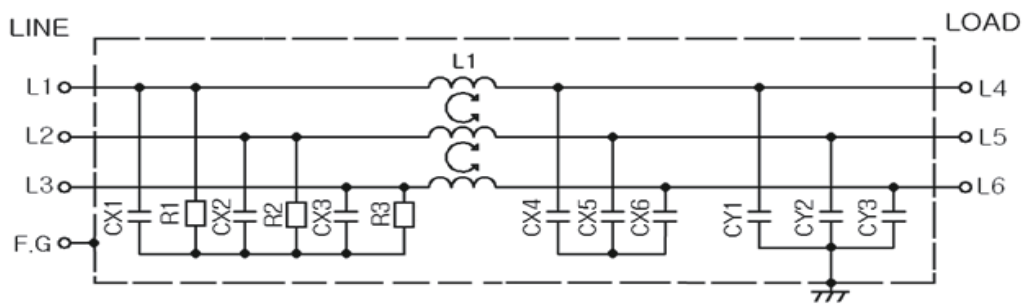

TB6-B200LB* ~ TB6-B400LB*

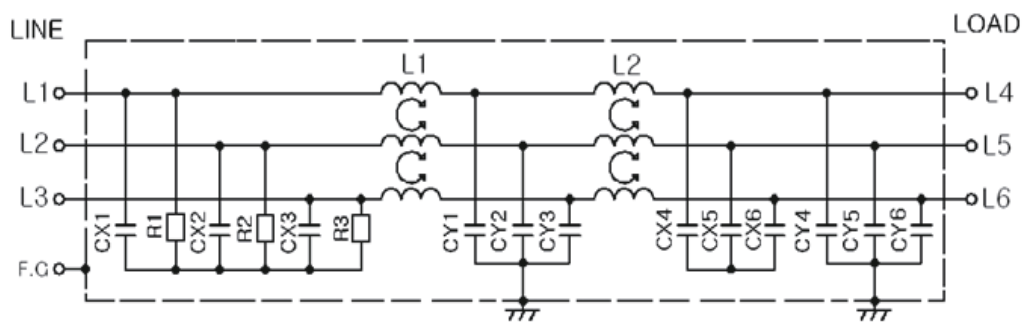

Attenuation Characteristics

Common mode (—)

Differential mode (—)

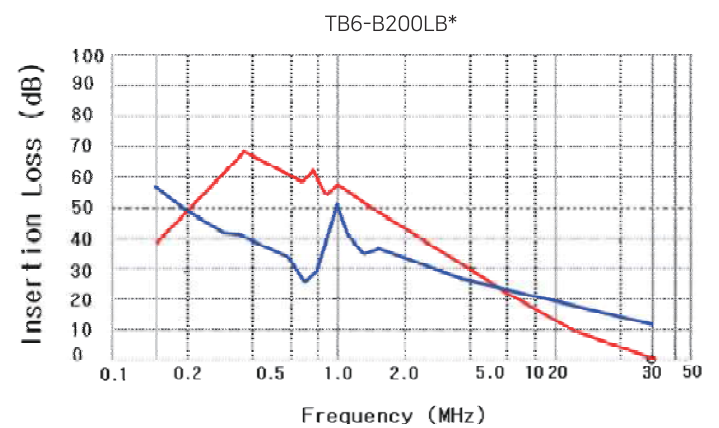
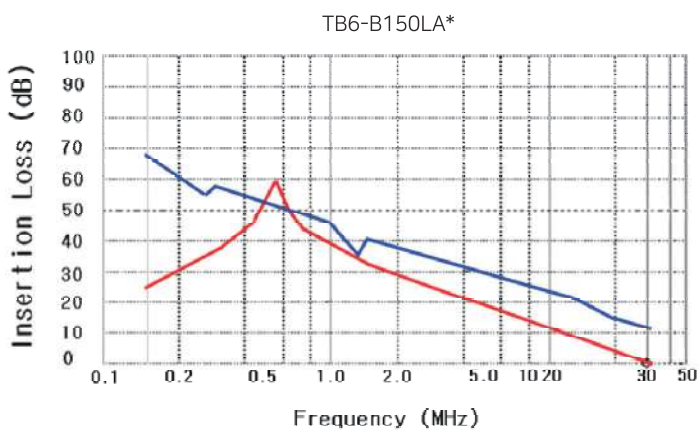
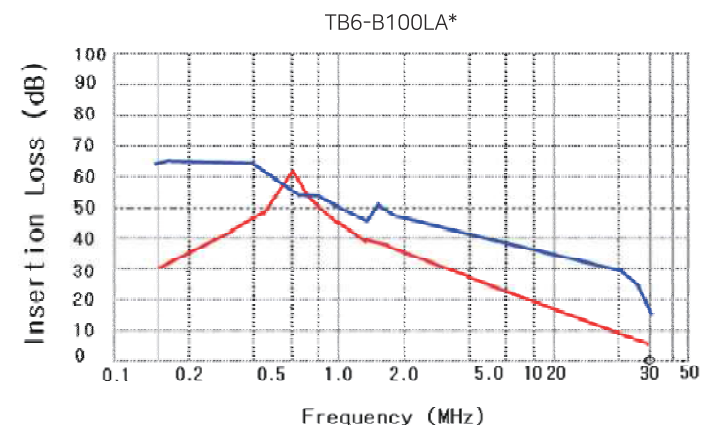
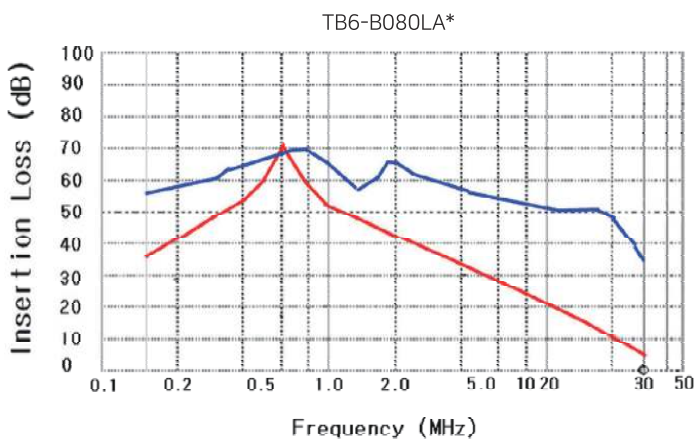
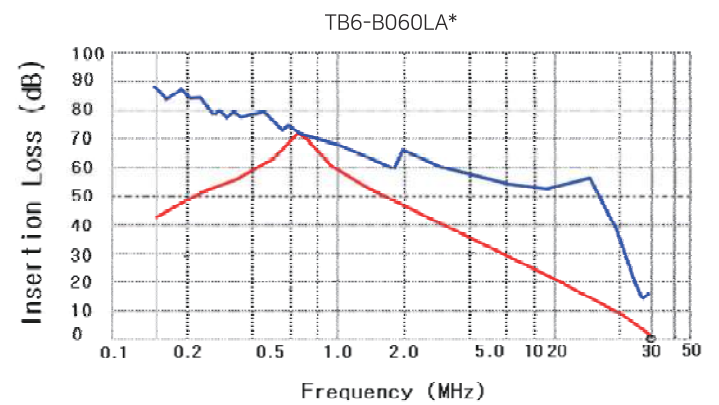
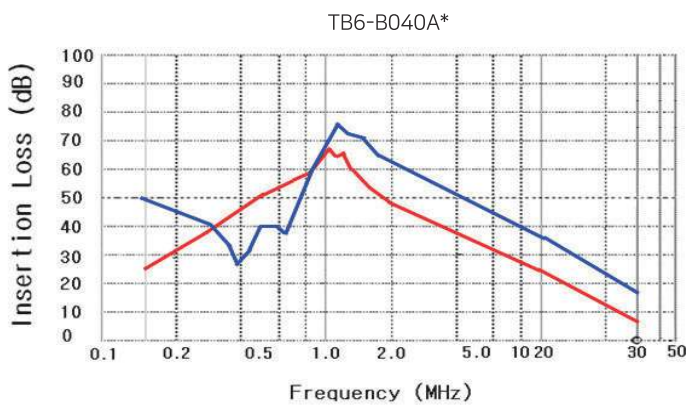
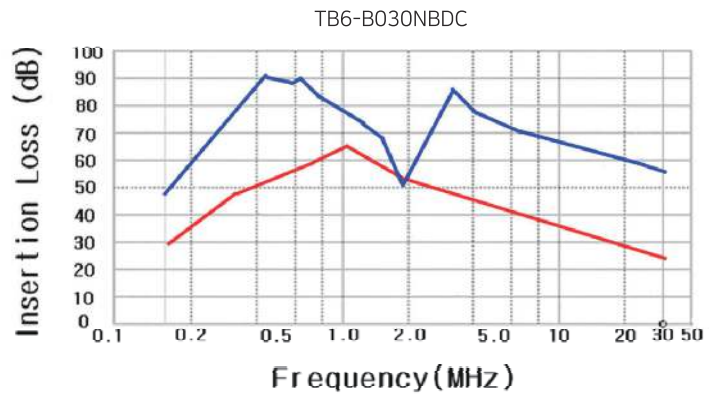
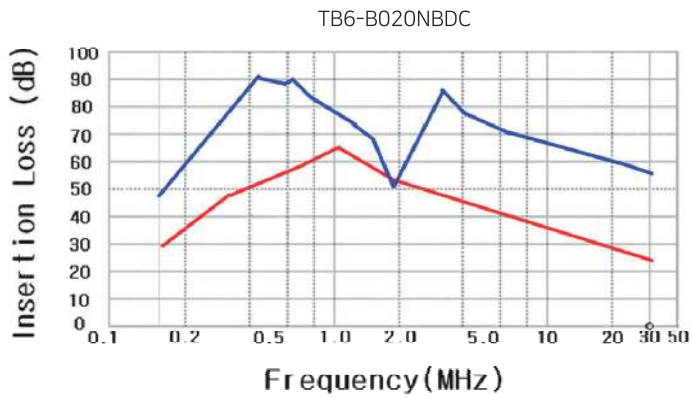

Attenuation Characteristics

Common mode (—)

Differential mode (—)

TB6-B250LB*

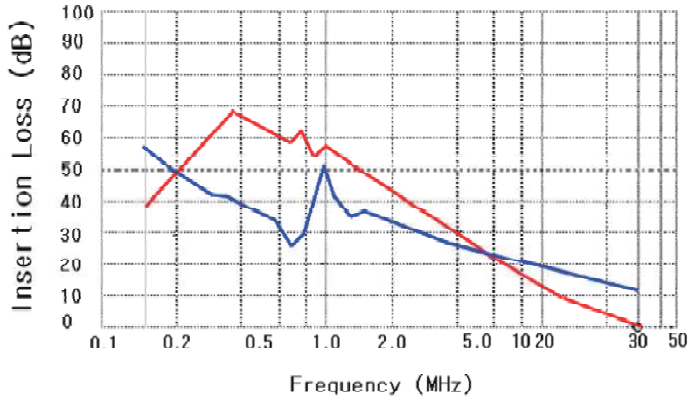

TB6-B400LB*

