

NHD-C12832A1Z-FSB-FBW-3V3

COG (Chip-On-Glass) Liquid Crystal Display Module

NHD-	Newhaven Display
C12832-	128 x 32 Pixels
A1Z-	Model
F-	Transflective
SB-	Side Blue LED Backlight
F-	FSTN Positive
B-	6:00 Optimal View
W-	Wide Temp
3V3-	3Vdd, 3V Backlight
	RoHS Compliant

Newhaven Display International, Inc.

2661 Galvin Ct.

Elgin IL, 60124

Ph: 847-844-8795

Fax: 847-844-8796

www.newhavendisplay.com

nhtech@newhavendisplay.com

nhsales@newhavendisplay.com

Document Revision History

Revision	Date	Description	Changed by
0	11/12/08	Initial Release	-
1	9/27/10	User guide reformat	BE
2	5/7/13	Electrical and Optical characteristics updated. Pin description, wiring diagram, mechanical drawing page and example initialization program updated.	JN
3	1/25/17	Mechanical Drawing, Electrical & Optical Char. Updated	SB
4	7/5/19	Added PCB Footprint Drawing	AS
5	1/30/19	Glass Panel Updated	SB
6	6/17/20	Updated 2D Mechanical Drawing & Quality Information	AS

Functions and Features

- 128 x 32 pixels
- 4-line SPI MPU interfaces
- Built-in ST7565R controller
- +3.0V power supply
- 1/33 duty cycle; 1/6 bias
- RoHS Compliant

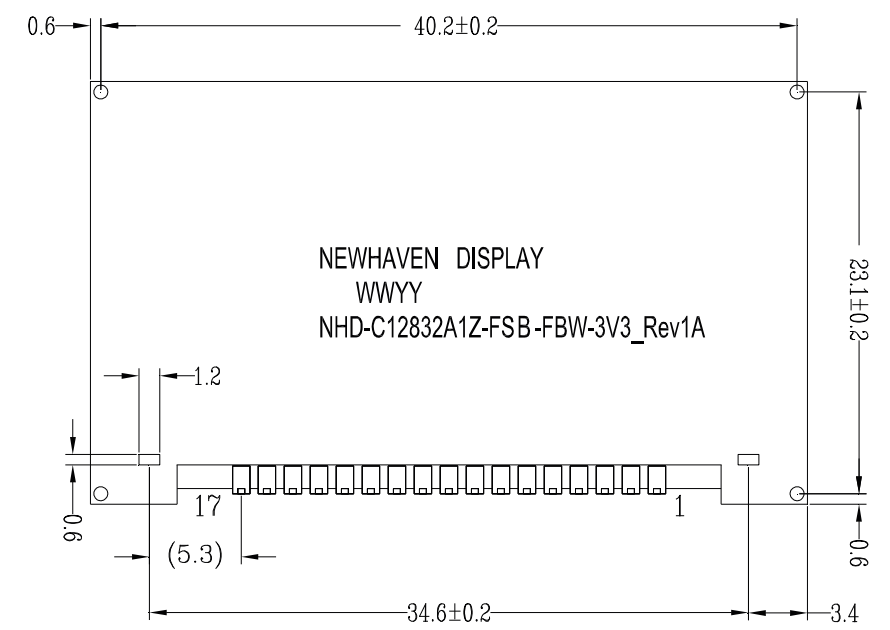
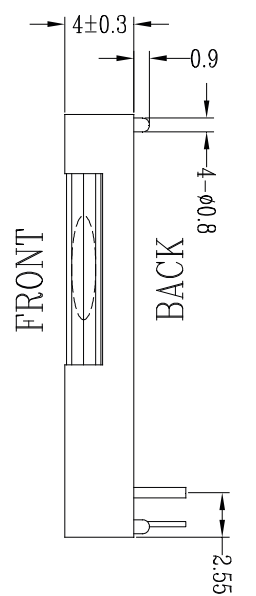
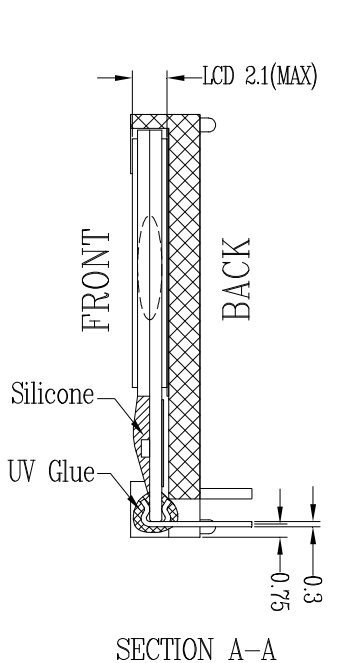
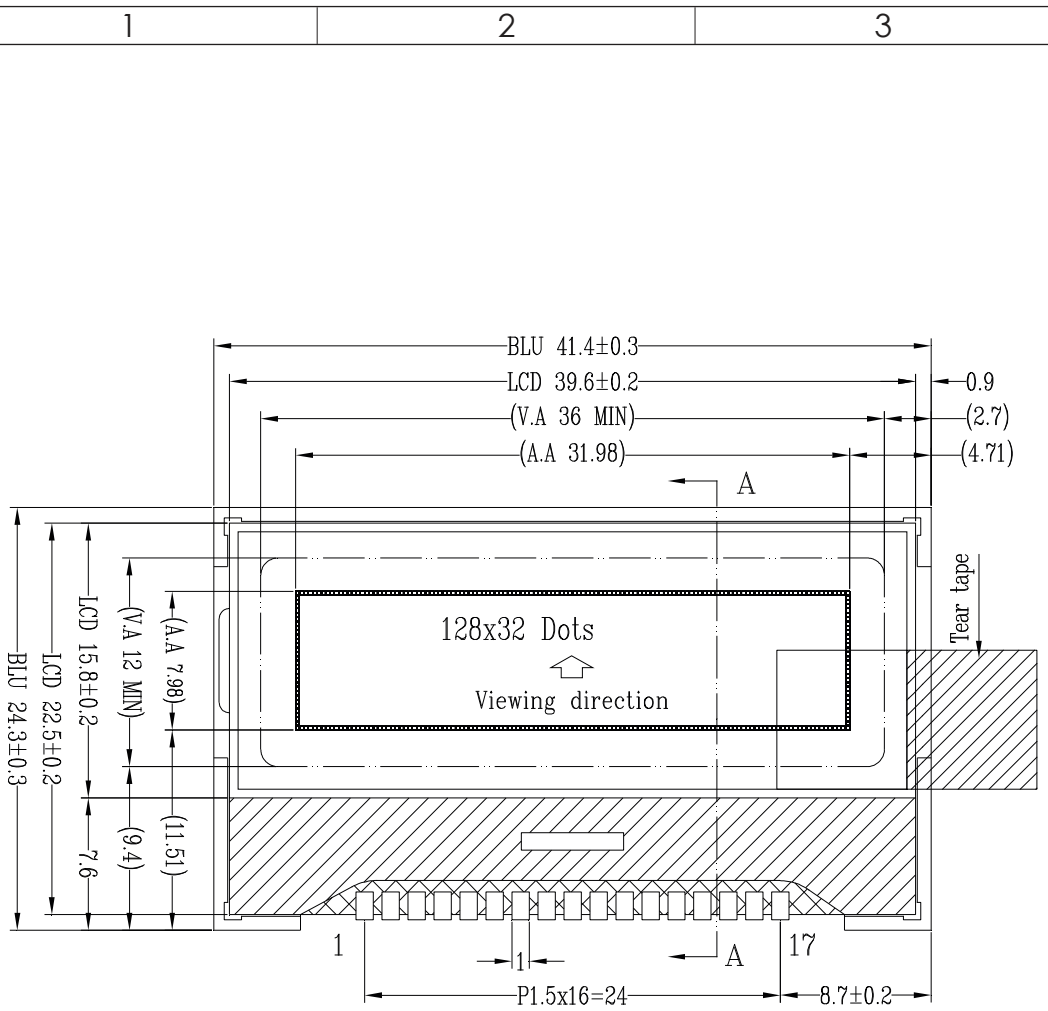

NEWHAVEN DISPLAY
WVYY
NHD-C12832A1Z-FSB-FBW-3V3_Rev1A

Pin Assignment	
NO.	Symbol
1	V0
2	V1
3	V2
4	V3
5	V4
6	C2-
7	C2+
8	C1+
9	C1-
10	VOUT
11	VSS
12	VDD
13	SI
14	SCL
15	A0
16	/RES
17	CS1B

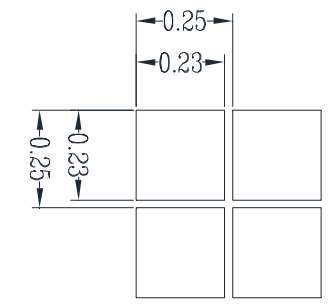
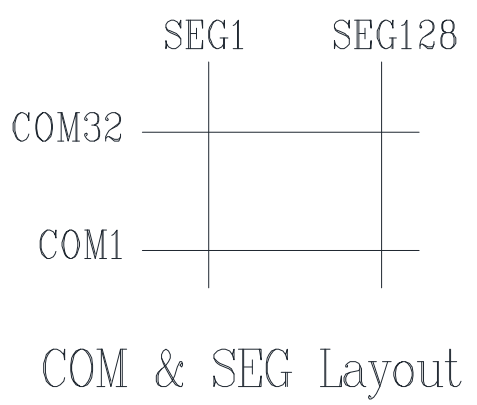
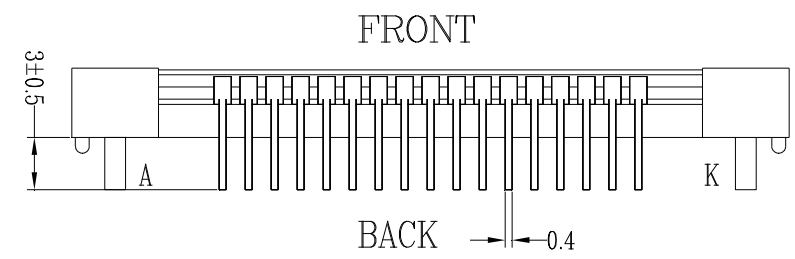

- Notes:**
1. Driver: 1/33 Duty, 1/6 Bias
 2. Voltage: 3.0V V_{DD}, 6V V_{LCD}
 3. Display Type: FSTN Positive / Transflective
 4. Optimal View: 6:00
 5. Backlight: Blue LED
 6. Driver IC: ST7565R 4-Wire SPI

STANDARD TOLERANCE: (UNLESS OTHERWISE SPECIFIED)			
LINEAR: ±0.3mm		DRAWING/PART NUMBER: NHD-C12832A1Z-FSB-FBW-3V3	
UNLESS OTHERWISE SPECIFIED: - DIMENSIONS ARE IN MILLIMETERS - THIRD ANGLE PROJECTION		DRAWN BY: A. Shah	APPROVED BY: A. Shah
		DRAWN DATE: 6/17/20	APPROVED DATE: 6/17/20
		DO NOT SCALE DRAWING	
		SHEET 1 OF 1	
THIS DRAWING IS SOLELY THE PROPERTY OF NEWHAVEN DISPLAY INTERNATIONAL, INC. THE INFORMATION IT CONTAINS IS NOT TO BE DISCLOSED, REPRODUCED OR COPIED IN WHOLE OR PART WITHOUT WRITTEN APPROVAL FROM NEWHAVEN DISPLAY.			



SYMBOL	REVISION	DATE

Recommended PCB Footprint

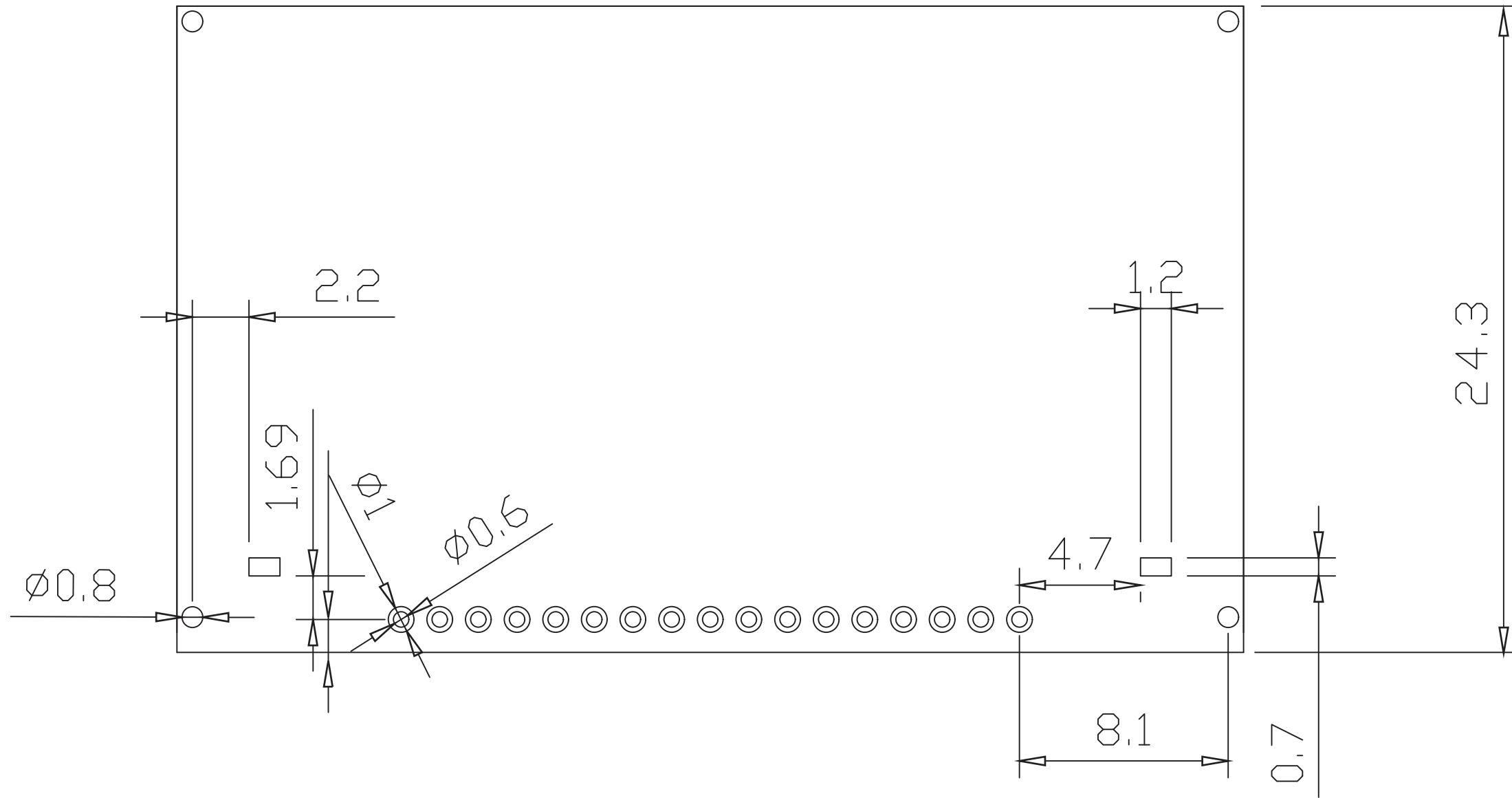
SYMBOL	REVISION	DATE



- Applicable Displays:
- 1) NHD-C12832A1Z-FSW-FBW-3V3
 - 2) NHD-C12832A1Z-NSW-BBW-3V3
 - 3) NHD-C12832A1Z-FSR-FBW-3V3
 - 4) NHD-C12832A1Z-FSB-FBW-3V3

STANDARD TOLERANCE: (UNLESS OTHERWISE SPECIFIED)		 NEWHAVEN DISPLAY INTERNATIONAL		
LINEAR: ±0.3mm				DRAWING/PART NUMBER: NHD-C12832A1Z-Footprint
UNLESS OTHERWISE SPECIFIED: - DIMENSIONS ARE IN MILLIMETERS - THIRD ANGLE PROJECTION 		DRAWN BY: S. Baxi	APPROVED BY: S. Baxi	SIZE: A3
		DRAWN DATE: 9/19/19	APPROVED DATE: 9/19/19	SCALE: NS
		DO NOT SCALE DRAWING		SHEET 1 OF 1
THIS DRAWING IS SOLELY THE PROPERTY OF NEWHAVEN DISPLAY INTERNATIONAL, INC. THE INFORMATION IT CONTAINS IS NOT TO BE DISCLOSED, REPRODUCED OR COPIED IN WHOLE OR PART WITHOUT WRITTEN APPROVAL FROM NEWHAVEN DISPLAY.				

Pin Description and Wiring Diagram

Pin No.	Symbol	External Connection	Function Description
1	V ₀	Power Supply	0.1μF – 1μF Capacitor to V _{SS}
2	V ₁	Power Supply	0.1μF – 1μF Capacitor to V _{SS}
3	V ₂	Power Supply	0.1μF – 1μF Capacitor to V _{SS}
4	V ₃	Power Supply	0.1μF – 1μF Capacitor to V _{SS}
5	V ₄	Power Supply	0.1μF – 1μF Capacitor to V _{SS}
6	C2-	Power Supply	Connect 1μF – 2.2μF Capacitor to C2+ (pin 7)
7	C2+	Power Supply	Connect 1μF – 2.2μF Capacitor to C2- (pin 6)
8	C1+	Power Supply	Connect 1μF – 2.2μF Capacitor to C1- (pin 9)
9	C1-	Power Supply	Connect 1μF – 2.2μF Capacitor to C1+ (pin 8)
10	V _{OUT}	Power Supply	Connect 1μF – 2.2μF Capacitor to V _{SS} (pin 11)
11	V _{SS}	Power Supply	Ground
12	V _{DD}	Power Supply	Supply Voltage for LCD and Logic (+3V)
13	SI	MPU	Serial Data
14	SCL	MPU	Serial Clock
15	A0	MPU	Register Select. A0=0: Instruction, A0=1: Data
16	/RST	MPU	Active LOW Reset signal
17	/CS1	MPU	Active LOW Chip Select signal
A	LED+	Power Supply	Backlight Anode(+3V)
K	LED-	Power Supply	Backlight Cathode (Ground)

Recommended LCD connector: 1.5mm pitch pins, solder directly into PCB

Backlight connector: 1.2mm Wide pins, solder directly into PCB **Mates with:** ---

Recommended Breakout Board: [NHD-PCB12832A1Z](#)

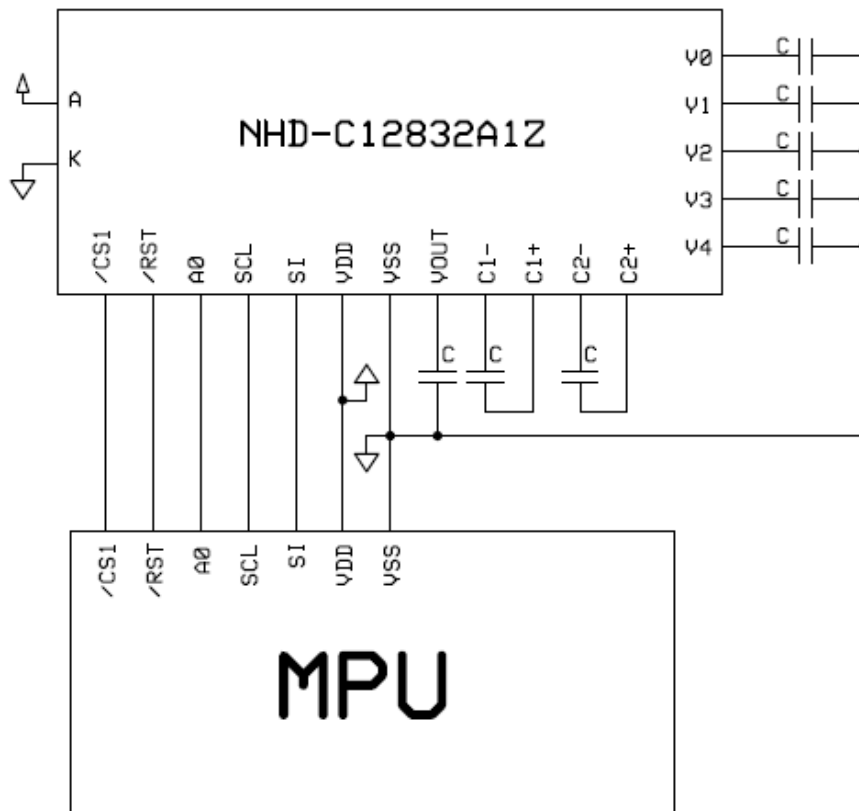

Electrical Characteristics

Item	Symbol	Condition	Min.	Typ.	Max.	Unit
Operating Temperature Range	T _{OP}	Absolute Max	-20	-	+70	°C
Storage Temperature Range	T _{ST}	Absolute Max	-30	-	+80	°C
Supply Voltage	V _{DD}	-	2.7	3.0	3.3	V
Supply Current	I _{DD}	V _{DD} =3.0V T _{OP} = 25°C	0.1	0.4	1.0	mA
Supply for LCD (contrast)	V _{LCD}		5.8	6.0	6.2	V
"H" Level input	V _{IH}	-	0.8 * V _{DD}	-	V _{DD}	V
"L" Level input	V _{IL}	-	V _{SS}	-	0.2 * V _{DD}	V
"H" Level output	V _{OH}	-	0.8 * V _{DD}	-	V _{DD}	V
"L" Level output	V _{OL}	-	V _{SS}	-	0.2 * V _{DD}	V
Backlight supply voltage	V _{LED}	-	2.9	3.0	3.1	V
Backlight supply current	I _{LED}	V _{LED} =3.0V	10	30	36	mA

Optical Characteristics

Item	Symbol	Condition	Min.	Typ.	Max.	Unit
Optimal Viewing Angles	Top	CR ≥ 2	-	20	-	°
	Bottom		-	40	-	°
	Left		-	40	-	°
	Right		-	40	-	°
Contrast Ratio	CR	-	2	6	-	-
Response Time	Rise	T _{OP} = 25°C	-	200	250	ms
	Fall		-	250	320	ms

Controller Information

Built-in ST7565R controller.

Please download specification at http://www.newhavendisplay.com/app_notes/ST7565R.pdf

Timing Characteristics

The 4-line SPI Interface

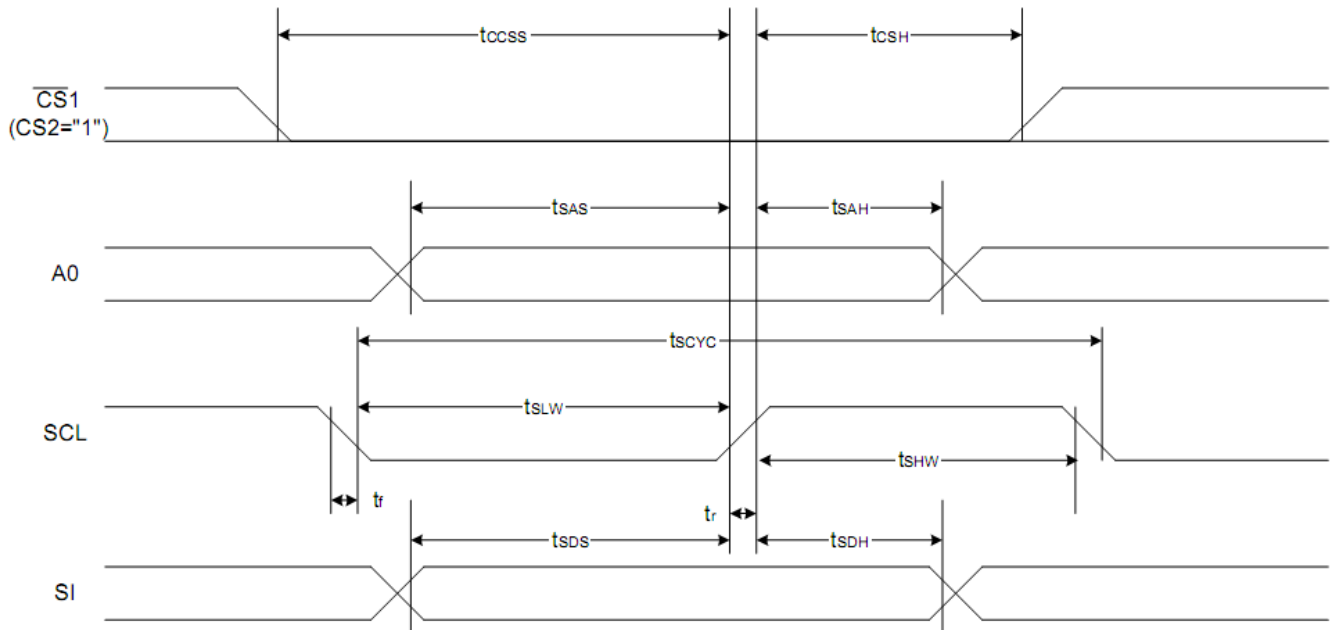

Item	Signal	Symbol	Condition	Rating		Units
				Min.	Max.	
4-line SPI Clock Period	SCL	T_{scyc}		50	—	ns
SCL "H" pulse width		T_{shw}		25	—	
SCL "L" pulse width		T_{SLW}		25	—	
Address setup time	A0	T_{sas}		20	—	
Address hold time		T_{sah}		10	—	
Data setup time	SI	T_{sds}		20	—	
Data hold time		T_{SDH}		10	—	
CS-SCL time	CS	T_{css}		20	—	
CS-SCL time		T_{csh}		40	—	

*1 The input signal rise and fall time (t_r , t_f) are specified at 15 ns or less.

*2 All timing is specified using 20% and 80% of V_{DD} as the standard.

Reset Timing

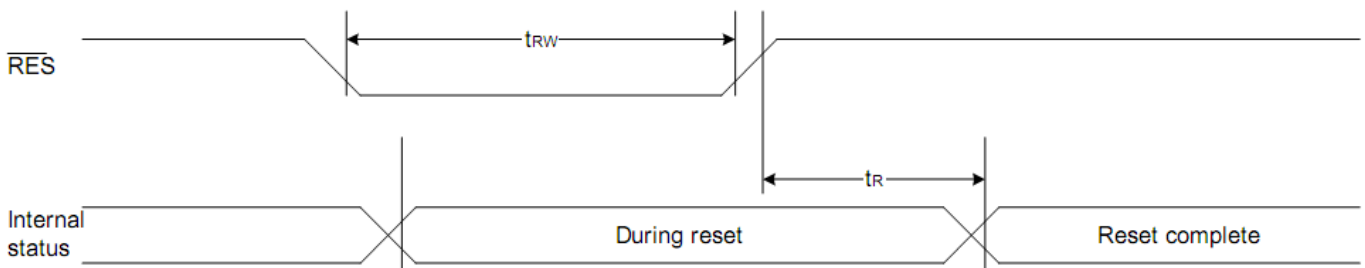

Table of Commands

Command	Command Code									Function				
	A0	/RD	/WR	D7	D6	D5	D4	D3	D2		D1	D0		
(1) Display ON/OFF	0	1	0	1	0	1	0	1	1	1	0	1	LCD display ON/OFF 0: OFF, 1: ON	
(2) Display start line set	0	1	0	0	1	Display start address					0	1	Sets the display RAM display start line address	
(3) Page address set	0	1	0	1	0	1	1	Page address				0	1	Sets the display RAM page address
(4) Column address set upper bit	0	1	0	0	0	0	1	Most significant column address				0	1	Sets the most significant 4 bits of the display RAM column address.
Column address set lower bit				0	0	0	0	Least significant column address				0	1	Sets the least significant 4 bits of the display RAM column address.
(5) Status read	0	0	1	Status				0	0	0	0	0	Reads the status data	
(6) Display data write	1	1	0	Write data							0	1	Writes to the display RAM	
(7) Display data read	1	0	1	Read data							0	1	Reads from the display RAM	
(8) ADC select	0	1	0	1	0	1	0	0	0	0	0	0	1	Sets the display RAM address SEG output correspondence 0: normal, 1: reverse
(9) Display normal/reverse	0	1	0	1	0	1	0	0	1	1	0	0	1	Sets the LCD display normal/ reverse 0: normal, 1: reverse
(10) Display all points ON/OFF	0	1	0	1	0	1	0	0	1	0	0	0	1	Display all points 0: normal display 1: all points ON
(11) LCD bias set	0	1	0	1	0	1	0	0	0	1	0	0	1	Sets the LCD drive voltage bias ratio 0: 1/9 bias, 1: 1/7 bias (ST7565R)
(12) Read-modify-write	0	1	0	1	1	1	0	0	0	0	0	0	0	Column address increment At write: +1 At read: 0
(13) End	0	1	0	1	1	1	0	1	1	1	0	0	0	Clear read/modify/write
(14) Reset	0	1	0	1	1	1	0	0	0	0	1	0	0	Internal reset
(15) Common output mode select	0	1	0	1	1	0	0	0	*	*	*	0	1	Select COM output scan direction 0: normal direction 1: reverse direction
(16) Power control set	0	1	0	0	0	1	0	1	Operating mode			0	1	Select internal power supply operating mode
(17) V ₀ voltage regulator internal resistor ratio set	0	1	0	0	0	1	0	0	Resistor ratio			0	1	Select internal resistor ratio(Rb/Ra) mode
(18) Electronic volume mode set	0	1	0	1	0	0	0	0	0	0	0	0	1	Set the V ₀ output voltage electronic volume register
Electronic volume register set				0	0	Electronic volume value					0	1		
(19) Sleep mode set	0	1	0	1	0	1	0	1	1	0	0	0	1	0: Sleep mode, 1: Normal mode
(20) Booster ratio set	0	1	0	1	1	1	1	1	0	0	0	0	0	select booster ratio 00: 2x,3x,4x 01: 5x 11: 6x
(21) NOP	0	1	0	1	1	1	0	0	0	0	1	1	1	Command for non-operation
(22) Test	0	1	0	1	1	1	1	*	*	*	*	*	*	Command for IC test. Do not use this command

Example Initialization Program

```
void data_out(unsigned char i) //Data Output Serial Interface
{
    unsigned int n;
    CS = 0;
    A0 = 1;
    for(n=0; n<8; n++){
        i <<=1;
        SCL = 0;
        P1 = i;
        delay(2);
        SCL = 1;
    }
    CS = 1;
}

void comm_out(unsigned char j) //Command Output Serial Interface
{
    unsigned int n;
    CS = 0;
    A0 = 0;
    for(n=0; n<8; n++){
        j <<=1;
        SCL = 0;
        P1 = j;
        delay(2);
        SCL = 1;
    }
    CS = 1;
}

/*****
*      Initialization For controller      *
*****/

void init_LCD()
{
    comm_out(0xA0);
    comm_out(0xAE);
    comm_out(0xC0);
    comm_out(0xA2);
    comm_out(0x2F);
    comm_out(0x21);
    comm_out(0x81);
    comm_out(0x3F);
}

/*****/
```

Quality Information

Test Item	Content of Test	Test Condition	Note
High Temperature storage	Endurance test applying the high storage temperature for a long time.	+80°C, 96hrs	2
Low Temperature storage	Endurance test applying the low storage temperature for a long time.	-30°C, 96hrs	1,2
High Temperature Operation	Endurance test applying the electric stress (voltage & current) and the high thermal stress for a long time.	+70°C, 96hrs	2
Low Temperature Operation	Endurance test applying the electric stress (voltage & current) and the low thermal stress for a long time.	-20°C, 96hrs	1,2
High Temperature / Humidity Operation	Endurance test applying the electric stress (voltage & current) and the high thermal with high humidity stress for a long time.	+40°C, 90% RH, 96hrs	1,2
Thermal Shock resistance	Endurance test applying the electric stress (voltage & current) during a cycle of low and high thermal stress.	-20°C, 30min -> 70°C, 60min = 1 cycle For 20 cycles	
Vibration test	Endurance test applying vibration to simulate transportation and use.	10-50Hz, 5G amplitude. 30min in each of 3 directions X, Y, Z	3
Static electricity test	Endurance test applying electric static discharge.	Air: ±8kV 150pF/330Ω, 5 Times	
		Contact: ±4kV 150pF/330Ω, 5 Times	

Note 1: No condensation to be observed.

Note 2: Conducted after 4 hours of storage at 25°C, 0%RH.

Note 3: Test performed on product itself, not inside a container.

Precautions for using LCDs/LCMs

See Precautions at www.newhavendisplay.com/specs/precautions.pdf

Warranty Information and Terms & Conditions

http://www.newhavendisplay.com/index.php?main_page=terms