

# TMC262 40V BOB Description

Document Revision V1.10 • 2021-Feb-01

## Module Top View

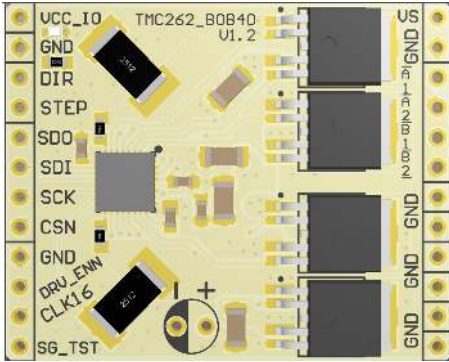

## Features and additional Resources

- TMC262-LA stepper predriver & 40V power stage
- Supply voltage 9-36V (40V limit with the onboard FETs)
- $I_{phase,RMS}$  up to 2.8A
- Config via SPI, control via step/direction
- >24V use with optional lowESR ELCO, ca. 150uF
- Board width 1.5", board height 1.2"
- 2x12 pin 0.1" header rows for pins/connectors
- Link to [additional information and IC data sheet](#)
- Link to [evaluation kit](#)

## Pin List

Left	Signal	Right	Signal
1	VCC_IO (3.3V or 5V)	13	VS (9-36V)
2	GND	14	GND
3	DIR	15	A1
4	STEP	16	A2
5	SDO (data out)	17	B1
6	SDI (data in)	18	B2
7	SCK (up to 6MHz with external CLK)	19	GND
8	CSN (active low)	20	GND
9	GND	21	GND
10	DRV_ENN (active low)	22	GND
11	CLK16 (pull to GND for internal CLK)	23	GND
12	SG_TST (see datasheet)	24	GND

## Bill of Materials

Pcs.	MPN	Value	Footprint	Description
1	MC0603B224K160CT	220nF,16V,10%	0603	Cap, Multicomp
1	MC0603X474K160CT	470nF,16V,10%	0603	Cap, Multicomp
1	MC0603B104K160CT	100nF,16V,10%	0603	Cap, Multicomp
1	MC0603F104M500CT	100nF,50V,20%	0603	Cap, Multicomp
4	GRM31CC8YA106KA12L	10uF,35V,10%	1206	Cap, Murata
1	LTST-C191TBKT-5A	20mA,2.8V,465nm	0603	LED, Lite-On
1	TMC262-LA	TMC262-LA	QFN32,5x5,0,5	PreDriver, TRINAMIC
2	TLR3A20WR075FTDG	0.075R,2W,1%	2512	Res, TE Connectivity
2	MCWR06X10R0FTL	10R,1%	0603	Res, Multicomp
1	MC0063W060311K	1k	0603	Res, Multicomp
4	FDD8424H	FDD8424H	SOT114P991X239-6N	FET,Fairchild Semi

## BOB Schematics

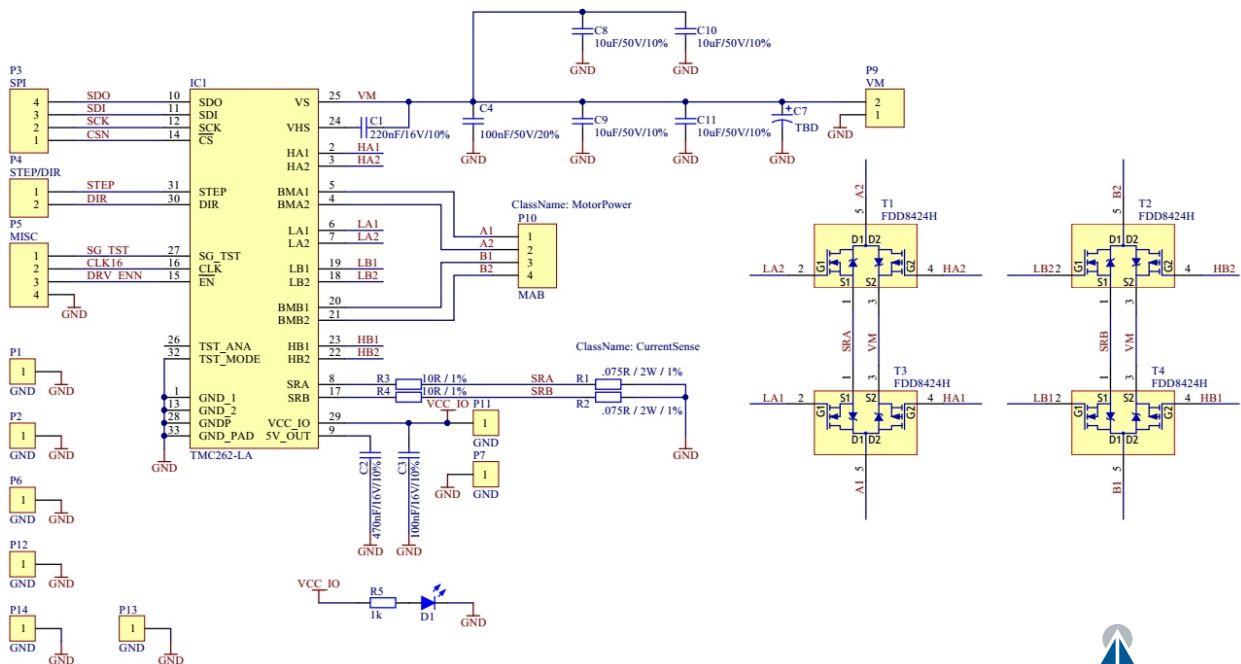

©2021 TRINAMIC Motion Control GmbH & Co. KG, Hamburg, Germany  
 Download newest version at: [www.trinamic.com](http://www.trinamic.com)

