

PRODUCT DATASHEET



SCA11H

Doc. No. 1323 Rev. 2

Table of Contents

1	Target Applications	3
2	Features, functions and benefits	3
2.1	Interfaces	3
2.1.1	Magnetic switch	3
2.1.2	LED-indicators	3
2.1.3	Power supply	3
2.1.4	Firmware	3
3	Product codes	4
4	Hardware Specification	4
4.1	Dimensions	4
4.2	Waterproofness	4
4.3	Housing materials	4
4.4	Block diagram	5
4.5	Absolute Maximum Ratings	5
4.6	Operating Conditions	5
4.7	Functional Characteristics	5
4.8	Electrical Characteristics	6
4.8.1	Electrical characteristics for BCG detection	6
4.8.2	RF Characteristics for IEEE802.11b - 2.4GHz	6
4.8.3	RF Characteristics for IEEE802.11g - 2.4GHz	6
4.8.4	RF Characteristics for IEEE802.11n - 2.4GHz	7
5	Reliability	7
6	AC Adapter	8
7	Packaging and Labeling	8
7.1	Packaging	8
7.1.1	Inner Box (325x260x108 mm ³)	8
7.1.2	Outer Box (340x278x500 mm ³)	9
7.2	Product labeling	9
8	Storage Conditions	9
9	Handling Condition	10
10	Cleaning	10
11	Operational Environment Conditions	10
12	Note	10
13	Document Change Control	11

1 Target Applications

- Hospitals, elderly care, assisted living
- Heart and respiration rate detection
- Cardiac output estimation
- Bed occupancy
- Stress and relaxation index
- Sleep quality monitoring

2 Features, functions and benefits

- Contactless measurement enables continuous monitoring without disturbing the patient
- Embedded heart and respiration rate signal processing with 1 Hz output rate
- IEEE802.11b/g/n WLAN with easy web page configuration
- Remote OTA FW upgrade capability

Supported functions are described in Section 2. Hardware detail specifications are defined in Section 4.

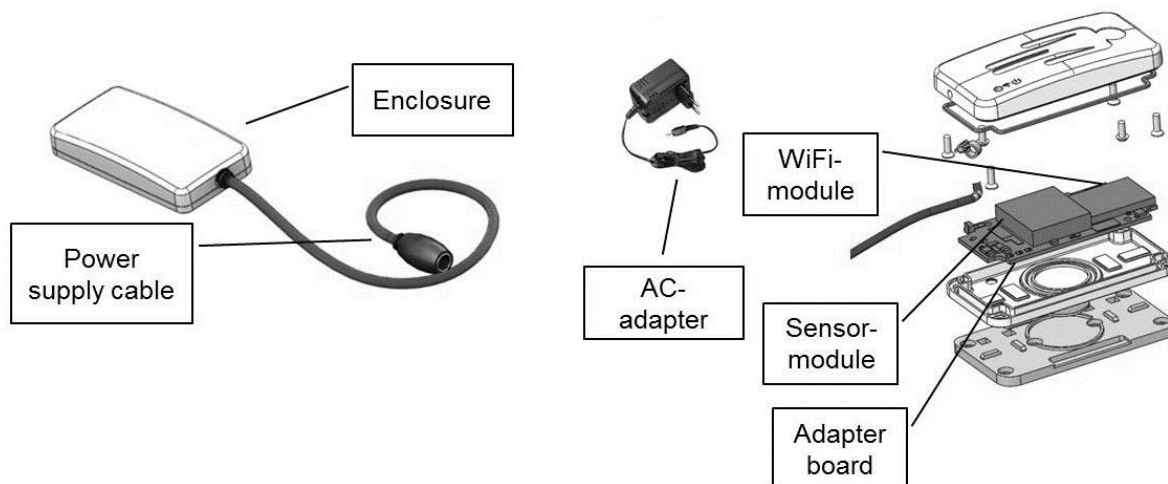

Figure 1 SCA11H assembly

2.1 Interfaces

2.1.1 Magnetic switch

Magnetic switch is used to control whether the device boots up to configuration or normal mode. Usage of the switch will be discussed in the Installation Guide.

2.1.2 LED-indicators

Two green and one yellow LED indicate the operation of the product. Operation details are discussed in the Installation Guide.

2.1.3 Power supply





9 V switching power supply with 2.1/5.5 mm plug is used.

2.1.4 Firmware

Please refer to Installation Guide for firmware features.

3 Product codes

Table 1

Product code	Quantity	SW version	Note www.iec.ch/worldplugs	
SCA11H-A01-Sample SCA11H-A01-036	1 36	1 1	AC-adapter type A US, Canada, Mexico and Japan...	
SCA11H-P01-Sample SCA11H-P01-036	1 36	1 1	AC-adapter type A China	
SCA11H-C01-Sample SCA11H-C01-036	1 36	1 1	AC-adapter type C Europe, South America and Asia...	
SCA11H-G01-Sample SCA11H-G01-036	1 36	1 1	AC-adapter type G UK, Ireland, Malta, Malaysia, Singapore...	

4 Hardware Specification

4.1 Dimensions

The enclosure size is 83.7 x 40.7 x 17.6 mm³.

4.2 Waterproofness

Designed for IP55 according to IEC 60529.

4.3 Housing materials

Table 2

Item	Color	Finishing	Material
Top cover	white	texture + polishing	ABS/PC C6600 8R8D063
Bottom panel	black	texture + polishing	ABS PA757
Adaptor plate	black	texture	ABS PA757
V-sealing	black		SSK95100
Power cable	white		50+/5P PVC
Magnet counter plate	silver	Galvanization	S235
Magnet	silver	NiCuNi	Nd-Fe-B/Sintered Nd-Fe-B
Button Head Screw	silver		SUS302
Countersunk Screw	silver		SUS302
Strain relief	Black		SSK95100

4.4 Block diagram

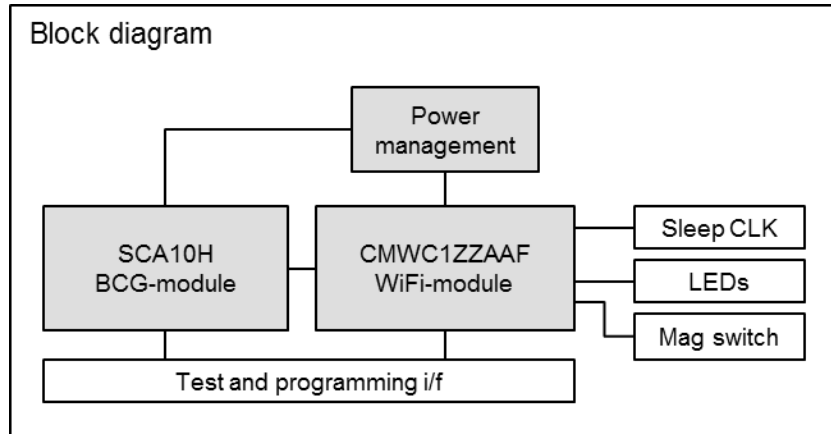

Figure 2 SCA11H block diagram

4.5 Absolute Maximum Ratings

Table 3

Item	Min	Max	Unit
DC Input voltage	-0.3	11	V
Input current	-	1	A
Storage temperature	-40	60	°C
Storage humidity	5	95	%RH

4.6 Operating Conditions

Table 4 Operating conditions

Item	Min	Typ.	Max	Unit
DC Input voltage	8.5	9.0	9.5	V
Current consumption	Local communication 1/s update rate		60	mA
	Local communication raw data transmission		65	mA
	Cloud communication 1/50s update rate		60	mA
Operating temperature	10	-	55	°C
Operating Humidity	10	-	90	%RH

4.7 Functional Characteristics

Table 5 Functional specification parameters

Parameter	Min	Typ	Max	Unit
Pulse detection range	40		120	BPM
Steady state pulse rate for test input ⁽¹⁾	48		52	BPM

⁽¹⁾ See SCA10H datasheet 1322 for details.

4.8 Electrical Characteristics

4.8.1 Electrical characteristics for BCG detection

Table 6

Item	Min	Typ.	Max	Unit
Acceleration raw data noise level ⁽¹⁾		1.3		LSB RMS
Acceleration sensor sensitivity ⁽²⁾		427		LSB/g
Acceleration sensor's step response gain ⁽³⁾	1			

⁽¹⁾ RMS-noise within the application bandwidth measured on stone table in raw data mode without any external vibration or noise.

⁽²⁾ Sensitivity measurement by tilting the module in test mode

⁽³⁾ Gain between BCG- and inclination channels when sensor's self-test is activated

4.8.2 RF Characteristics for IEEE802.11b - 2.4GHz

Table 7 ⁽¹⁾

Condition: 25 °C, 11 Mbps mode unless otherwise specified, measured at antenna feedpoint.

Item	Contents		
Specification	IEEE802.11b-2.4GHz		
Mode	DSSS / CCK		
Channel frequency (spacing)	2412 to 2472 MHz (5MHz)		
Data rate	1, 2, 5.5, 11Mbps		
Frequency tolerance	-25	25	ppm
Transmitter	Min.	Max.	unit
Power Levels	-	18	dBm
Spectrum Mask			
(a) 1st side lobes	-	-30	dBr
(b) 2nd side lobes	-	-50	dBr
RF Carrier Suppression	15	-	dB
Modulation Accuracy	-	35	%
Receiver	Min.	Max.	Unit
Minimum Input Level (FER< 8%)	-	-76	dBm
Maximum Input Level (FER < 8%)	-10	-	dBm
Adjacent Channel Rejection (FER< 8%)	35	-	dB

¹⁾ For reference only

4.8.3 RF Characteristics for IEEE802.11g - 2.4GHz

Table 8 ⁽¹⁾

Condition: 25 °C, 54 Mbps mode unless otherwise specified, measured at antenna feedpoint.

Item	Contents		
Specification	IEEE802.11g-2.4GHz		
Mode	OFDM		
Channel frequency (spacing)	2412 to 2472 MHz (5MHz)		
Data rate	6, 9, 12, 18, 24, 36, 48, 54Mbps		
Frequency tolerance	-20	20	ppm
Transmitter	Min.	Max.	unit
Power Levels	-	14	dBm
Spectrum Mask			
(a) at fc +/- 11MHz	-	-20	dBr

Item	Contents		
(b) at fc +/- 20MHz	-	-28	dBr
(c) at fc > +/-30MHz	-	-40	dBr
Constellation Error	-	-25	dB
Receiver	Min.	Max.	Unit
Minimum Input Level (PER < 10%)	-	-65	dBm
Maximum Input Level (PER < 10%)	-30	-	dBm
Adjacent Channel Rejection (FER< 10%)	-1	-	dB

¹⁾ For reference only

4.8.4 RF Characteristics for IEEE802.11n - 2.4GHz

Table 9 ⁽¹⁾

Condition: 25 °C, 65 Mbps (MCS7 – HT 20MHz) mode unless otherwise specified, measured at antenna feed point.

Item	Contents		
Specification	IEEE802.11n-2.4GHz		
Mode	OFDM		
Channel frequency (spacing)	2412 to 2472 MHz (5MHz)		
Data rate	6.5, 13, 19.5, 26, 39, 52, 58.5, 65Mbps		
Frequency tolerance	-25	25	ppm
Transmitter	Min.	Max.	unit
Power Levels	-	14	dBm
	Spectrum Mask		
(a) at fc +/- 11MHz	-	-20	dBr
(b) at fc +/- 20MHz	-	-28	dBr
(c) at fc > +/-30MHz	-	-45	dBr
Constellation Error	-	-28	dB
Receiver	Min.	Max.	Unit
Minimum Input Level (PER < 10%)	-	-64	dBm
Maximum Input Level (PER < 10%)	-20	-	dBm
Adjacent Channel Rejection (FER< 10%)	-2	-	dB

¹⁾ For reference only

5 Reliability

SCA11H has been verified against the following test conditions:

Table 10 Test items and conditions

Test item	Test condition
1. Temperature humidity bake (THB)	- 95RH/55°C - 9V biased - 300h - N=5
2. Low temperature storage life (LTSL)	- -40°C - 300 h - N=5
3. High temperature storage life (HTSL)	- +60°C - 150 h - N=5

Test item	Test condition
4. Temperature cycling test (TCY)	- 0°C...+55°C - 30 min dwell time - 200 cycles (c) - N=5
5. Mixed gas test	- IEC60068-2-60 method 2 - 14 days - N=3
6. Vibration test	- 10<f<55Hz, log sweep, amplitude=1.5 mm - 30 min/axis, total 1.5 hrs - N=3
7. Drop test	- 2 directional drops on each 6 sides (=12 drops) on concrete - Drop height 0.75 m - N=3
8. ESD (HBM)	- Air discharge ±6 kV - Contact discharge ±3 kV - N=3
9. Water and dust proofness (IP55)	- 6.3 mm nozzle, 3 m distance, 12.5 l/min, 30 kPa water pressure - N=3 - IEC 60529 dust, 0.1 - 0.3 kPa underpressure, 2 h - N=3

6 AC Adapter

For detailed information, please refer to AC adapter product specification 1629.

7 Packaging and Labeling

7.1 Packaging

7.1.1 Inner Box (325x260x108 mm³)

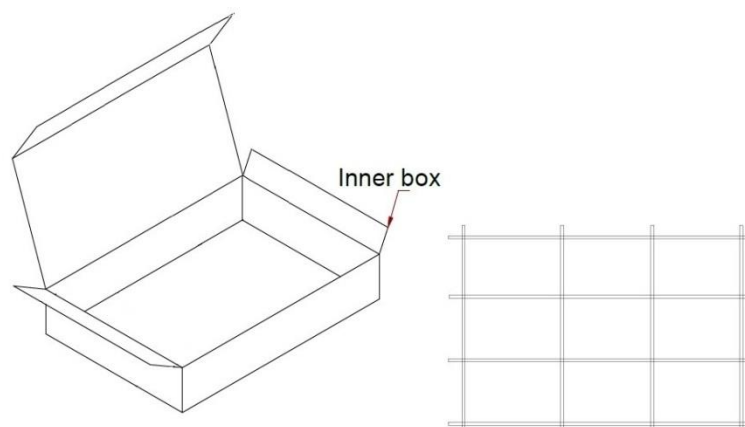

Figure 3 Inner box 9 pcs

7.1.2 Outer Box (340x278x500 mm³)

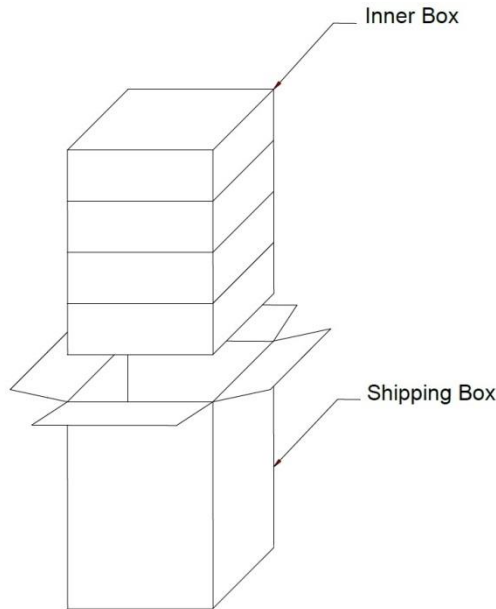

Figure 4 Outer box 36 pcs

7.2 Product labeling

Product label (Figure 5) is placed on the bottom panel of the sensor node. The size is approx. 32.5 x 32.5 mm²

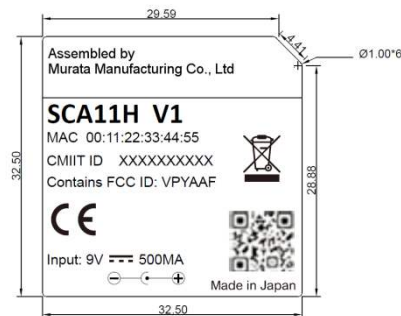

Figure 5 Product label

8 Storage Conditions

- The product shall be stored without opening the packing.
- The outer boxes including the products and gift boxes shall not be stored outdoor.
- The product shall not be stored in the place where the product may become corroded e.g. due to corrosive gas (Cl₂, NH₃, SO₂, Nox, etc.).
- Any excess mechanical shock shall not be applied in order not to damage the packing materials and product itself.

9 Handling Condition

Be careful in handling or transporting products because excessive stress or mechanical shock may damage products.

Warranty is void if device is opened.

10 Cleaning

See instructions in Installation Guide.

11 Operational Environment Conditions

Products are designed to work for electronic products under normal environmental conditions (ambient temperature, humidity and pressure). Therefore, products have no problems to be used under the similar conditions to the above-mentioned. However, if products are used under the following circumstances, it may damage products and leakage of electricity and abnormal temperature may occur.

- In an atmosphere containing corrosive gas (Cl₂, NH₃, SO_x, NO_x etc.).
- In an atmosphere containing combustible and volatile gases.

If there are possibilities for products to be used under the preceding clause, consult with Murata before actual use.

12 Note

Please make sure that our product SCA11H has been evaluated and confirmed against your specifications. Please also note that our product SCA11H has not been qualified for medical or similar use where it might directly or indirectly cause damage to the third party's life, body or property.

All the items and parameters in this product specification have been prescribed on the premise that our product is used for the purpose, under the condition and in the environment agreed upon between you and us. You are requested not to use our product deviating from such agreement.

We consider it is not appropriate to include other terms and conditions for transaction warranty in your product specifications, drawings or other technical documents. Therefore, even if your original part of this product specification includes such terms and conditions as warranty clause, product liability clause, or intellectual property infringement liability clause, we are not able to accept such terms and conditions in our product specification unless they are based on the governmental regulation and we have agreed in a separate contract. We would like you to discuss them when negotiating the contract.

13 Document Change Control

Rev.	Date	Change Description
1	01-Sep-15	Document moved to new control system and template, table 2, 4 and 10 updated, section 4.2 updated, reference in 4.7 updated, section 6 updated.
2	04-Dec-15	Updated table 10. Updated product codes. Updated section 9.