

Technical Data Coin-type Manganese Dioxide Lithium Battery

Type: CR1616

Made in China

2022.Ver1.0

TOSHIBA LIFESTYLE PRODUCTS & SERVICES CORPORATION

Ratings

Battery system		Coin-type Manganese Dioxide Lithium Battery
Item		
Battery type		CR1616
Nominal Voltage		3.0V
Standard Capacity [Condition]		50 mAh [on continuous discharge under 30kΩ load to 2.0V end-point at 20deg.C]
Terminals	Cap Terminals	SUS + Ni plate
	Base Terminals	SUS + Ni plate
Outer dimensions	Diameter	φ16.0(0/-0.3)mm
	Overall height	1.6(0/-0.2)mm
Usable temperature range		-20 ~ 65deg.C
Storage temperature range		

This is only for reference. (not guaranteed.) The information contained herein may be changed without prior notice.

CR1616 Discharge Characteristics

Test condition : cotinuous discharge, Initial, 20deg.C

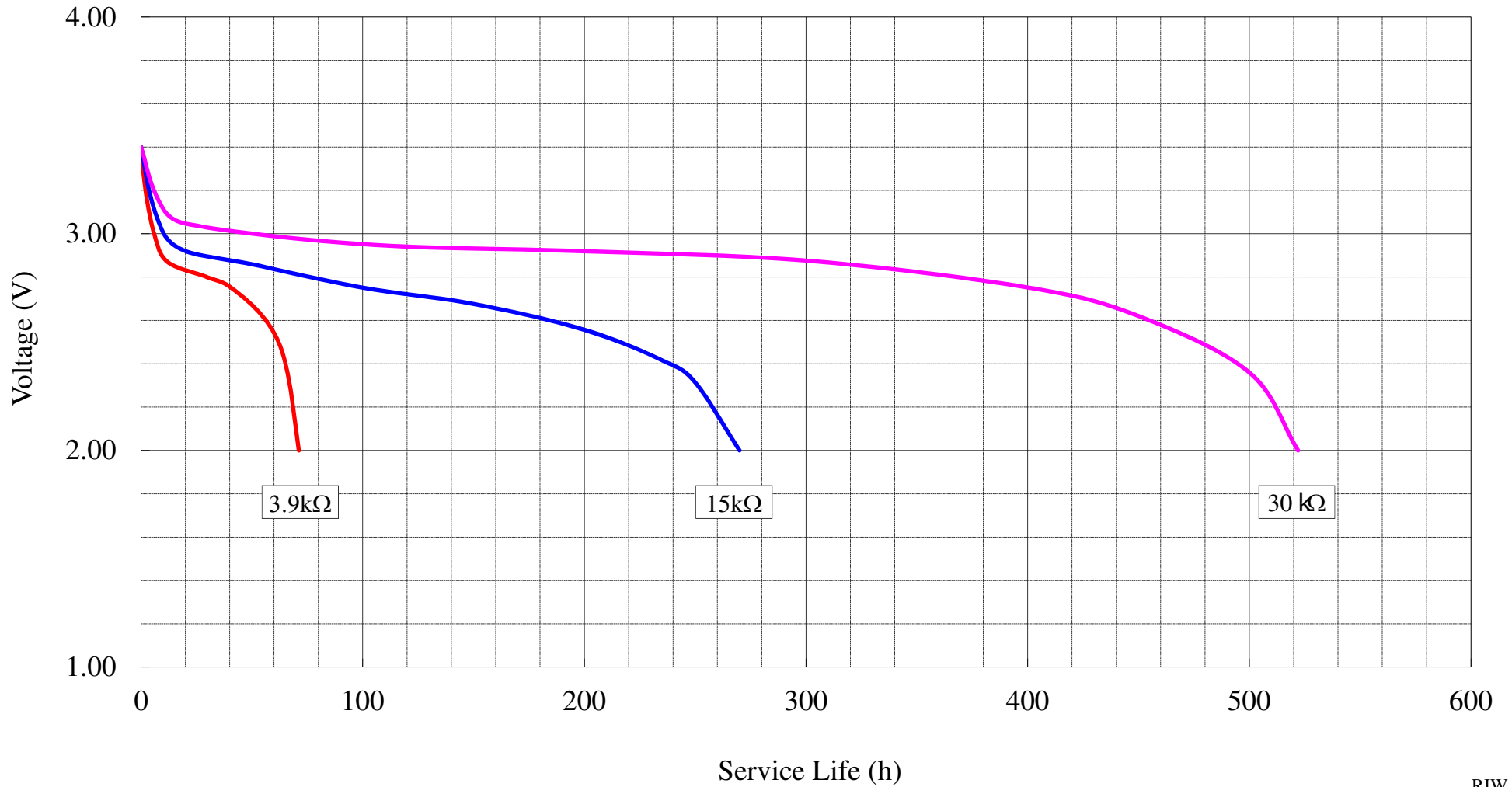

RIW

This is only for reference. (not guaranteed.) The information contained herein may be changed without prior notice.

Proprietary materials of TOSHIBA LIFESTYLE PRODUCTS & SERVICES CORPORATION

CR1616 Discharge Characteristics

Test condition: 30kΩ continuous discharge, Initial

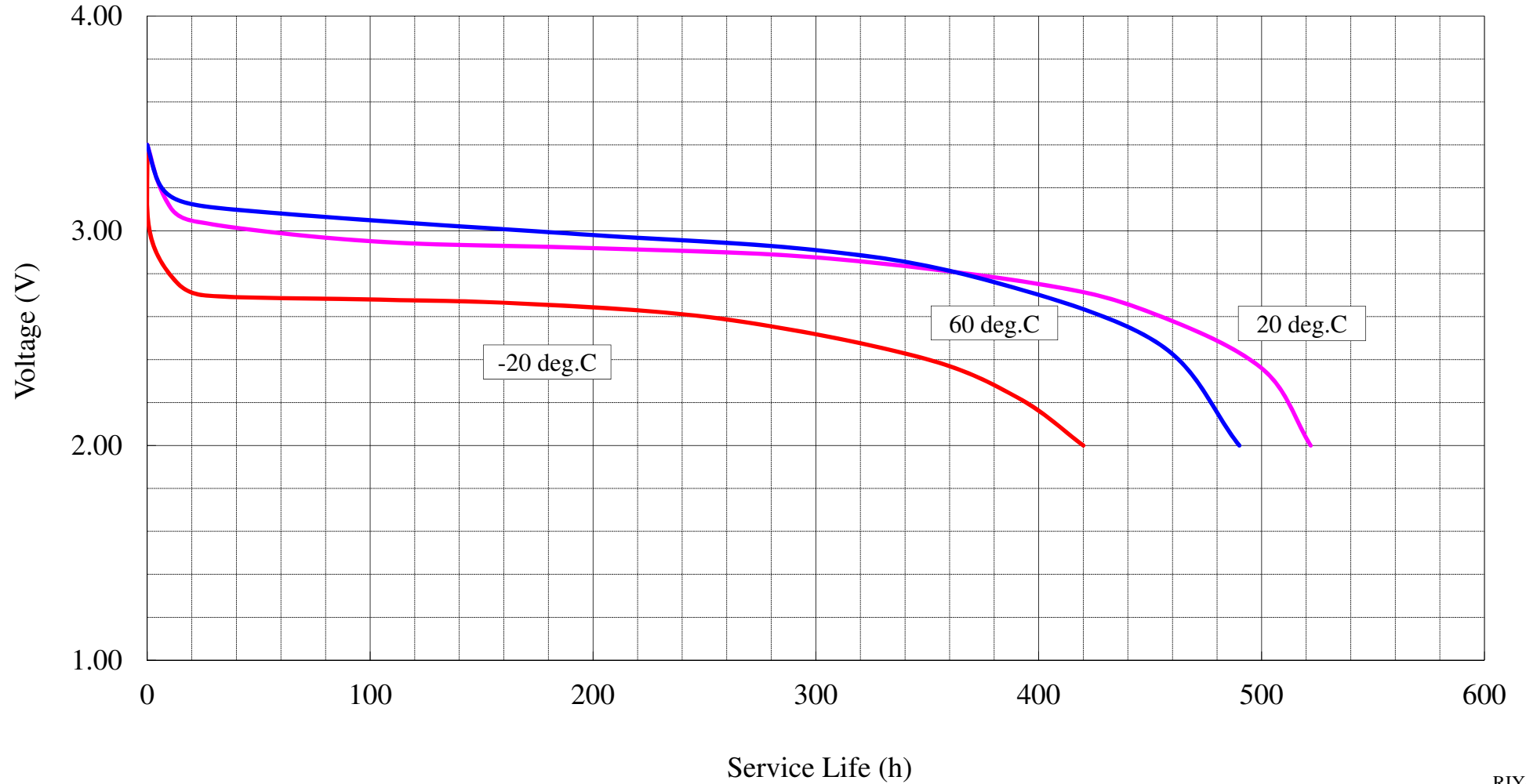

This is only for reference. (not guaranteed.) The information contained herein may be changed without prior notice.

Proprietary materials of TOSHIBA LIFESTYLE PRODUCTS & SERVICES CORPORATION

CR1616 Load Resistance vs Capacity

Test condition : Initial, 20deg.C

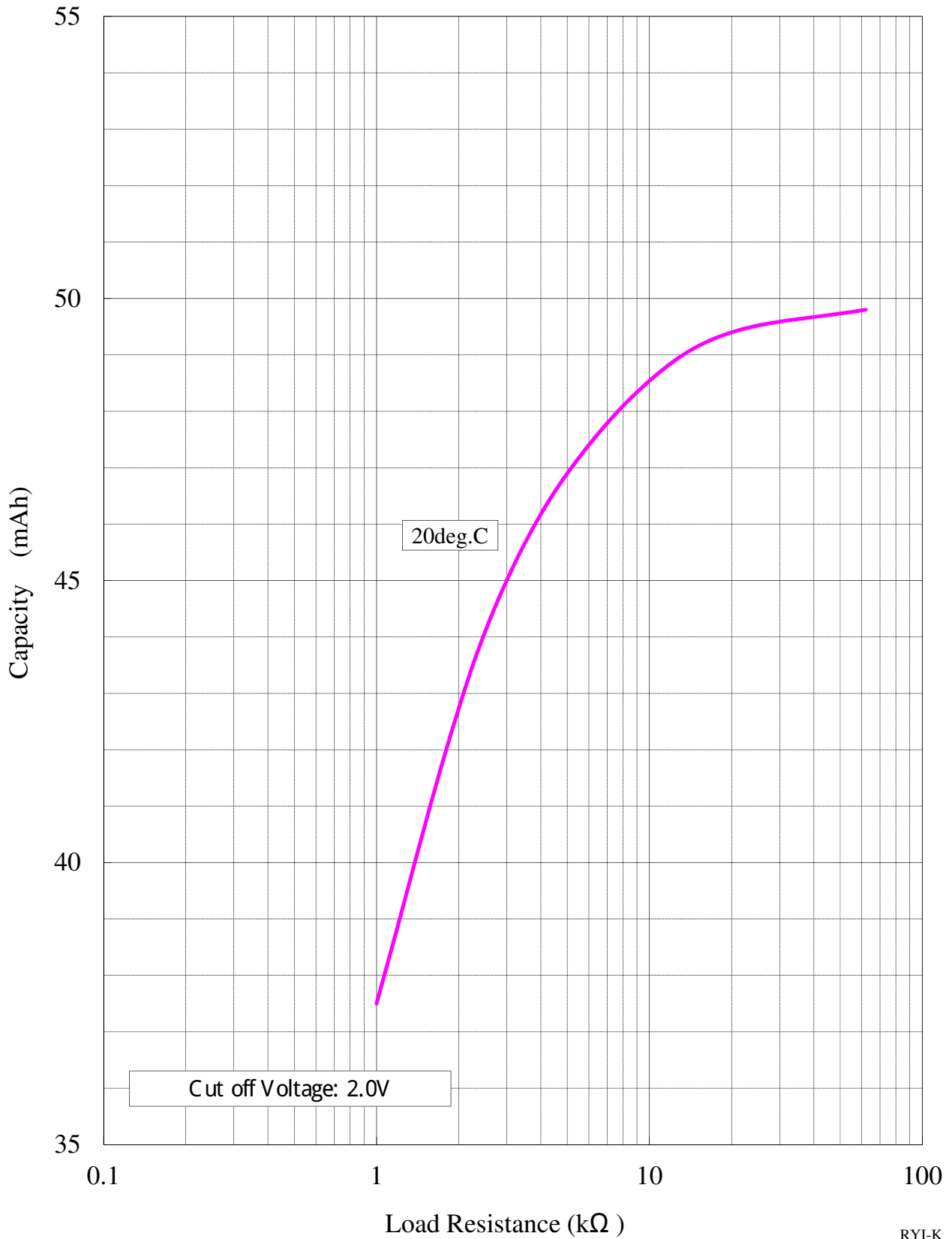

RYI-K

This is only for reference. (not guaranteed.) The information contained herein may be changed without prior notice.

Proprietary materials of TOSHIBA LIFESTYLE PRODUCTS & SERVICES CORPORATION

CR1616 Safety Evaluation Test

	n	Conditions	Requirements
Vibration test	5	Amplitude: 1.0mm Frequency: 10 to 55 to 10Hz Sweep: 1minute Period: 2h per each direction of X and Y axes, 4h in total	Open-circuit voltage is to be kept same as initial value. No abnormal appearance and no substandard dimensions are to be observed.
Weighing test	5	Weight of 19.8N(2kgf) is laid for 1 hour and 9.8N(1kgf) for 24 hours respectively on all over negative side of cells.	Open-circuit voltage is to be kept same as initial value. No abnormal appearance and no substandard dimensions are to be observed.
Drop test	5	Number of drops: 10 times Height: 75cm Floor: Concrete Direction: Free	Open-circuit voltage is to be kept same as initial value. No abnormal appearance and no substandard dimensions are to be observed.
Heat test	5	Cells are kept stored for 24hrs. Temperature: 80+/-2deg.C Humidity: 70%RH or less.	Open-circuit voltage is to be kept same as initial value. No abnormal appearance and no substandard dimensions are to be observed.
Temperature cycle	5	Temperature : -10deg.C ↔ 60deg.C (4h/Cycle, 6cycle/day,20Day)	Open-circuit voltage is to be kept same as initial value. No abnormal appearance and no substandard dimensions are to be observed.
Short-circuit test	5	Cells are Short-circuited for 48 hours.	No burst, No fire

CR1616 Leakage Performance

Test items		Electrolyte Leakage (%)			
		20days	40days	60days	90days
Test condition	Storage period				
		20days	40days	60days	90days
Storage at high temperature and high humidity	45deg.C-70%RH	0	0	0	0
	60deg.C-90%RH	0	0	-	-
Temperature cycle	Temperature : -10deg.C ⇔ 60deg.C (4h/Cycle, 6cycle/day,20Day)	0	-	-	-

This is only for reference. (not guaranteed.) The information contained herein may be changed without prior notice.

CR1616 Outline Drawing

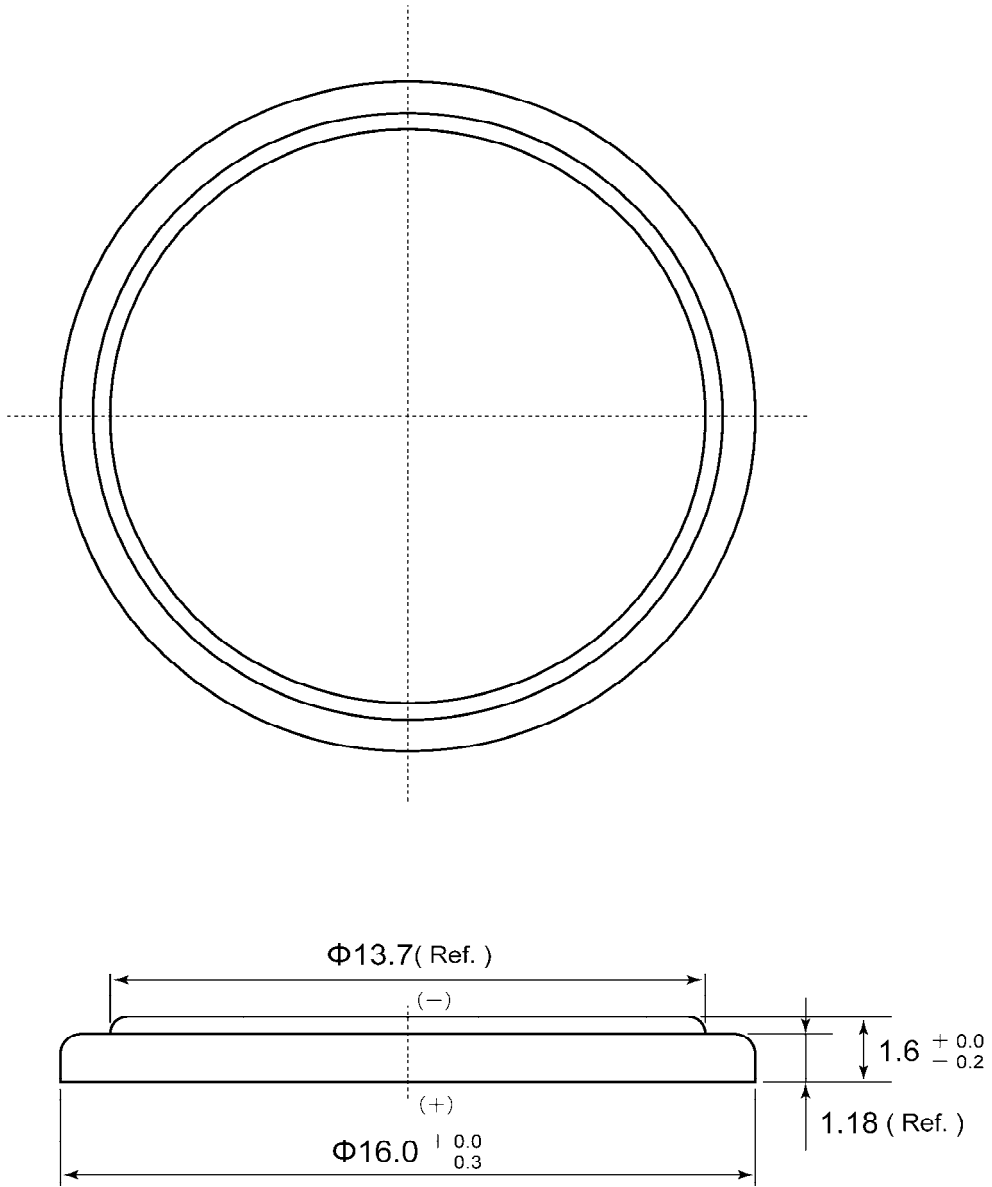

Unit: mm

This is only for reference. (not guaranteed.) The information contained herein may be changed without prior notice.

Proprietary materials of TOSHIBA LIFESTYLE PRODUCTS & SERVICES CORPORATION