

General Description

The AOZ8101 is a transient voltage suppressor array designed to protect high speed data lines from Electro Static Discharge (ESD) and lightning.

This device incorporates two surge rated, low capacitance steering diodes and a Transient Voltage Suppressor (TVS) in a single package. During transient conditions, the steering diodes direct the transient to either the positive side of the power supply line or to ground. They may be used to meet the ESD immunity requirements of IEC 61000-4-2, Level 4 ($\pm 15\text{kV}$ air, $\pm 8\text{kV}$ contact discharge).

The AOZ8101 comes in RoHS compliant SOT-23-3 package and is rated over a -40°C to $+85^{\circ}\text{C}$ ambient temperature range.

Features

- ESD protection for high-speed data lines:
 - IEC 61000-4-2, level 4 (ESD) immunity test
 - $\pm 30\text{kV}$ (air discharge) and $\pm 30\text{kV}$ (contact discharge)
 - IEC 61000-4-5 (Lightning) 8A (8/20 μs)
 - Human Body Model (HBM) $\pm 30\text{kV}$
- Array of surge rated diodes with internal TVS diode
- Protects two I/O lines
- Low capacitance between I/O lines: 0.7pF
- Low clamping voltage
- Low operating voltage: 5.0V

Applications

- Monitors and flat panel displays
- Set-top box
- USB 2.0 power and data line protection
- Video graphics cards
- Notebook computers



Typical Application

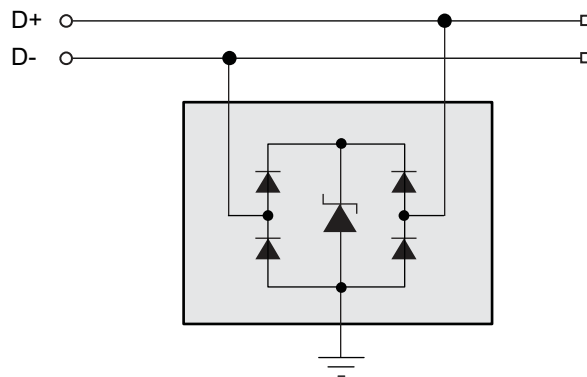

Figure 1. USB Ports

Ordering Information

Part Number	Ambient Temperature Range	Package	Environmental
AOZ8101CI	-40°C to +85°C	SOT-23-3	Green Product



AOS Green Products use reduced levels of Halogens, and are also RoHS compliant.
Please visit www.aosmd.com/web/media/AOSGreenPolicy.pdf for additional information.

Pin Configuration

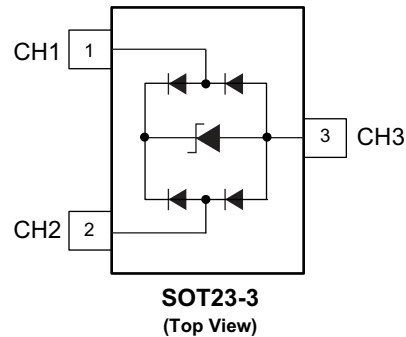

Absolute Maximum Ratings

Exceeding the Absolute Maximum ratings may damage the device.

Parameter	Rating
Peak Pulse Current (I_{PP}), $t_P = 8/20\mu s$	8A
Storage Temperature (T_S)	-65°C to +150°C
ESD Rating per IEC61000-4-2, contact ⁽¹⁾	±30kV
ESD Rating per IEC61000-4-2, air ⁽¹⁾	±30kV
ESD Rating per Human Body Model ⁽²⁾	±30kV

Notes:

- IEC 61000-4-2 discharge with $C_{Discharge} = 150pF$, $R_{Discharge} = 330\Omega$.
- Human Body Discharge per MIL-STD-883, Method 3015 $C_{Discharge} = 100pF$, $R_{Discharge} = 1.5k\Omega$.

Maximum Operating Ratings

Parameter	Rating
Junction Temperature (T_J)	-40°C to +125°C

Electrical Characteristics

$T_A = 25^\circ\text{C}$ unless otherwise specified. Specifications in **BOLD** indicate a temperature range of -40°C to $+85^\circ\text{C}$.

Symbol	Parameter	Conditions	Min.	Typ.	Max.	Units
V_{RWM}	Reverse Working Voltage	Between VP and VN ⁽³⁾			5.5	V
V_{BR}	Reverse Breakdown Voltage	$I_T = 100\mu\text{A}$, between VP and VN ⁽⁴⁾	6.6			V
I_R	Reverse Leakage Current	$V_{RWM} = 5\text{V}$, between VP and VN			1	μA
V_F	Diode Forward Voltage	$I_F = 15\text{mA}$	0.70	0.85	1	V
V_{CL}	Channel Clamp Voltage Positive Transients Negative Transient	$I_{PP} = 8\text{A}$, $t_p = 100\text{ns}$, any I/O pin to Ground ⁽⁵⁾		2.4 -2.6		V V
	Channel Clamp Voltage Positive Transients Negative Transient	$I_{PP} = 16\text{A}$, $t_p = 100\text{ns}$, any I/O pin to Ground ⁽⁵⁾		3.1 -3.6		V V
C_j	Channel Input Capacitance	$V_R = 0\text{V}$, $f = 1\text{MHz}$, between I/O pins ⁽⁶⁾		0.7		pF
		$V_R = 0\text{V}$, $f = 1\text{MHz}$, any I/O pin to Ground ⁽⁶⁾		1.3		pF
R_{DYN}	Dynamic Resistance	$I_{TLP} = 8\text{A}$ to 16A		0.15		Ω

Notes:

- The working peak reverse voltage, V_{RWM} , should be equal to or greater than the DC or continuous peak operating voltage level.
- V_{BR} is measured at the pulse test current I_T .
- Measurements performed using a 100ns Transmission Line Pulse (TLP) system.
- Measure performed with no external capacitor on V_P .

Typical Operating Characteristics

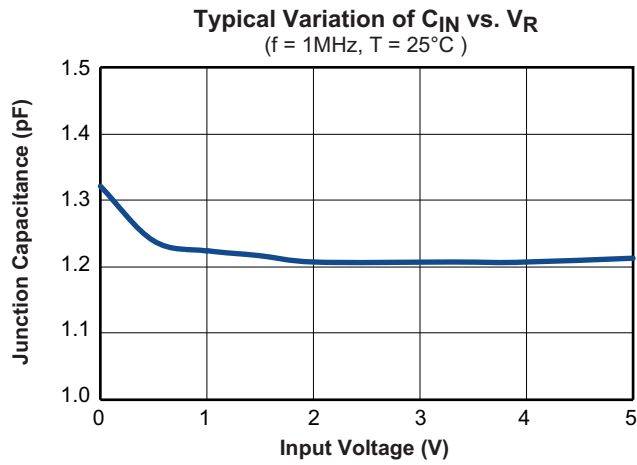
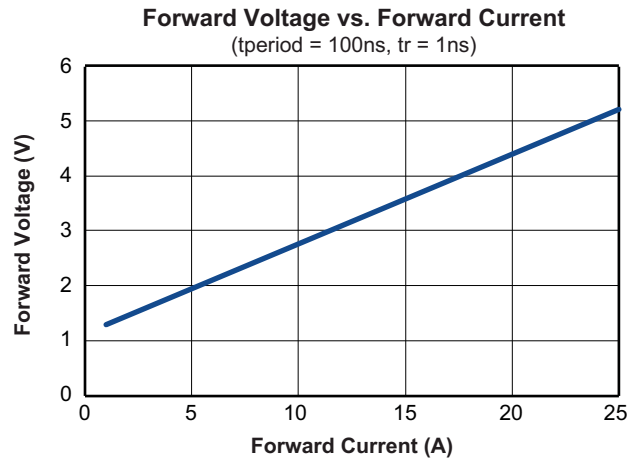
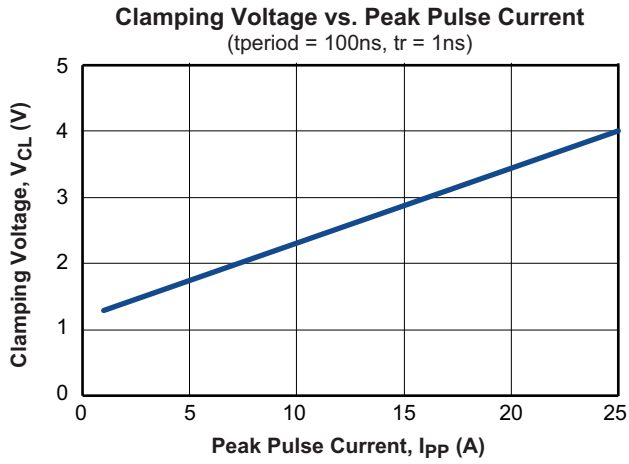

Application Information

The AOZ8101 TVS is design to protect two data lines from fast damaging transient over-voltage by clamping it to a reference. When the transient on a protected data line exceed the reference voltage the steering diode is forward bias thus, conducting the harmful ESD transient away from the sensitive circuitry under protection.

PCB Layout Guidelines

Printed circuit board layout is the key to achieving the highest level of surge immunity on power and data lines. The location of the protection devices on the PCB is the simplest and most important design rule to follow. The AOZ8101 devices should be located as close as possible to the noise source. The placement of the AOZ8101 devices should be used on all data and power lines that enter or exit the PCB at the I/O connector. In most systems, surge pulses occur on data and power lines that enter the PCB through the I/O connector. Placing the AOZ8101 devices as close as possible to the noise source ensures that a surge voltage will be clamped before the pulse can be coupled into adjacent PCB traces. In addition, the PCB should use the shortest possible traces. A short trace length equates to low impedance, which ensures that the surge energy will be dissipated by the AOZ8101 device. Long signal traces will act as antennas to receive energy from fields that are produced by the ESD pulse. By keeping line lengths as short as possible, the efficiency of the line to act as an antenna for ESD related fields is reduced. Minimize interconnecting line lengths by placing devices with the most interconnect as close together as possible. The protection circuits should shunt the surge voltage to either the reference or chassis ground. Shunting the surge voltage directly to the IC's signal ground can cause ground bounce. The clamping performance of TVS diodes on a single ground PCB can be improved by minimizing the impedance with relatively short and wide ground traces. The PCB layout and IC package parasitic inductances can cause significant overshoot to the TVS's

clamping voltage. The inductance of the PCB can be reduced by using short trace lengths and multiple layers with separate ground and power planes. One effective method to minimize loop problems is to incorporate a ground plane in the PCB design. The AOZ8101 ultra-low capacitance TVS is designed to protect two high speed data transmission lines from transient over-voltages by clamping them to a fixed reference. The low inductance and construction minimizes voltage overshoot during high current surges. When the voltage on the protected line exceeds the reference voltage the internal steering diodes are forward biased, conducting the transient current away from the sensitive circuitry.

Good circuit board layout is critical for the suppression of ESD induced transients. The following guidelines are recommended:

1. Place the TVS near the IO terminals or connectors to restrict transient coupling.
2. Fill unused portions of the PCB with ground plane.
3. Minimize the path length between the TVS and the protected line.
4. Minimize all conductive loops including power and ground loops.
5. The ESD transient return path to ground should be kept as short as possible.
6. Never run critical signals near board edges.
7. Use ground planes whenever possible.
8. Avoid running critical signal traces (clocks, resets, etc.) near PCB edges.
9. Separate chassis ground traces from components and signal traces by at least 4mm.
10. Keep the chassis ground trace length-to-width ratio <5:1 to minimize inductance.
11. Protect all external connections with TVS diodes.

Package Dimensions, SOT23-3L

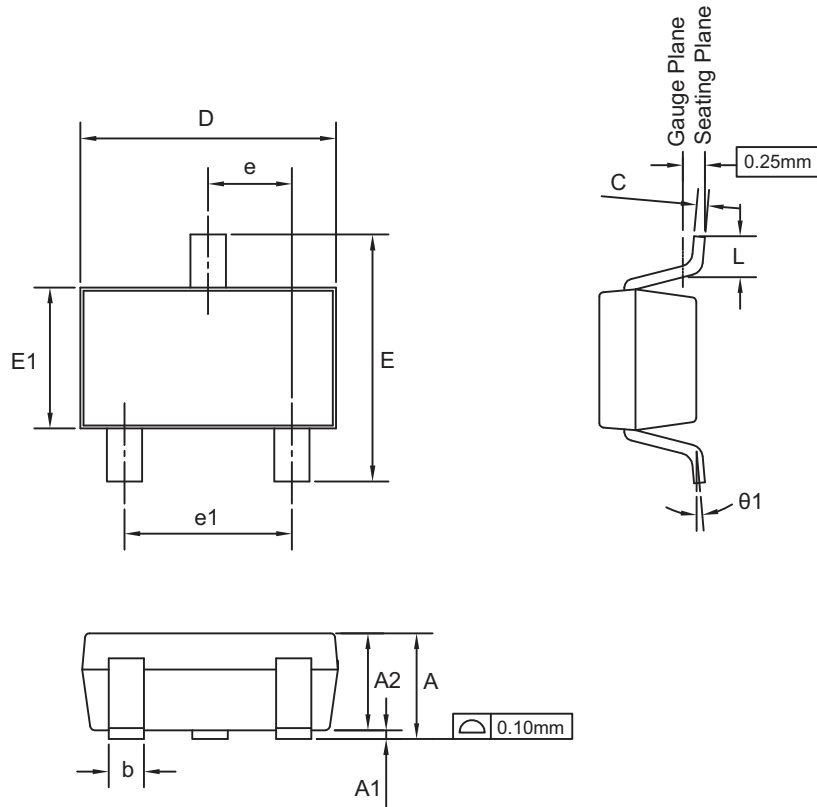

RECOMMENDED LAND PATTERN

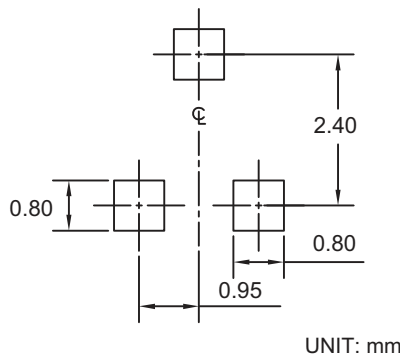

Dimensions in millimeters

Symbols	Min.	Nom.	Max.
A	0.85	—	1.25
A1	0.00	—	0.13
A2	0.70	1.00	1.15
b	0.30	0.40	0.50
c	0.08	0.13	0.20
D	2.80	2.90	3.10
E	2.60	2.80	3.00
E1	1.40	1.60	1.80
e	0.95 BSC		
e1	1.90 BSC		
L	0.30	—	0.60
θ1	0°	5°	8°

Dimensions in inches

Symbols	Min.	Nom.	Max.
A	0.033	—	0.049
A1	0.000	—	0.005
A2	0.028	0.039	0.045
b	0.012	0.016	0.020
c	0.003	0.005	0.008
D	0.110	0.114	0.122
E	0.102	0.110	0.118
E1	0.055	0.063	0.071
e	0.037 BSC		
e1	0.075 BSC		
L	0.012	—	0.024
θ1	0°	5°	8°

Notes:

1. Package body sizes exclude mold flash or gate burrs. Mold flash at the non-lead sides should be less than 5mils each.
2. Tolerance ±0.100mm (4mils) unless otherwise specified.
3. Dimension L is measured in gauge plane.
4. Controlling dimension is millimeter, converted inch dimensions are not necessarily exact.
5. All dimensions are in millimeters.

Tape and Reel Dimensions, SOT23-3L

Tape

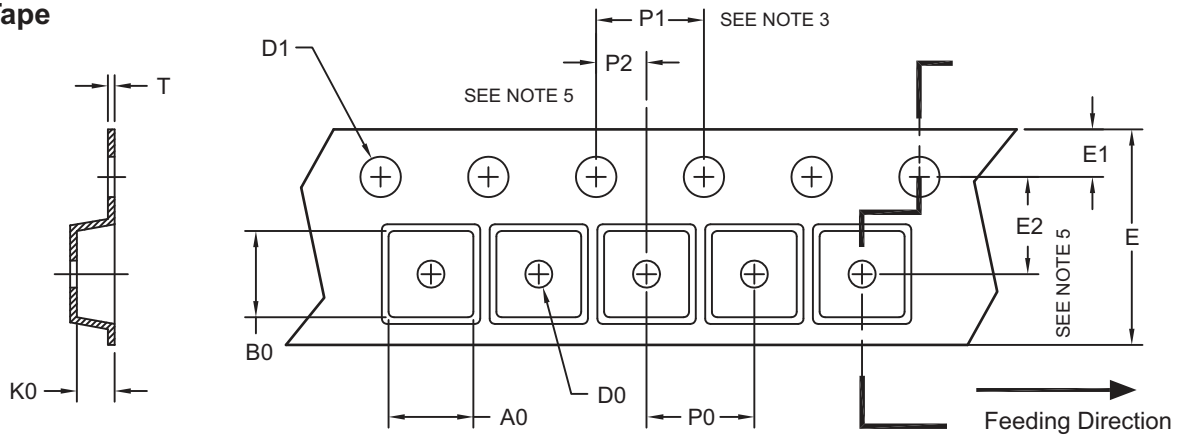

Unit: mm

Package	A0	B0	K0	D0	D1	E	E1	E2	P0	P1	P2	T
SOT23 (8mm)	3.15 ±0.10	3.20 ±0.10	1.40 ±0.10	1.50 MIN.	1.50 ±0.10	8.00 ±0.30	1.75 ±0.10	3.50 ±0.05	4.00 ±0.10	4.00 ±0.10	2.00 ±0.05	0.15 ~ 0.30

Reel

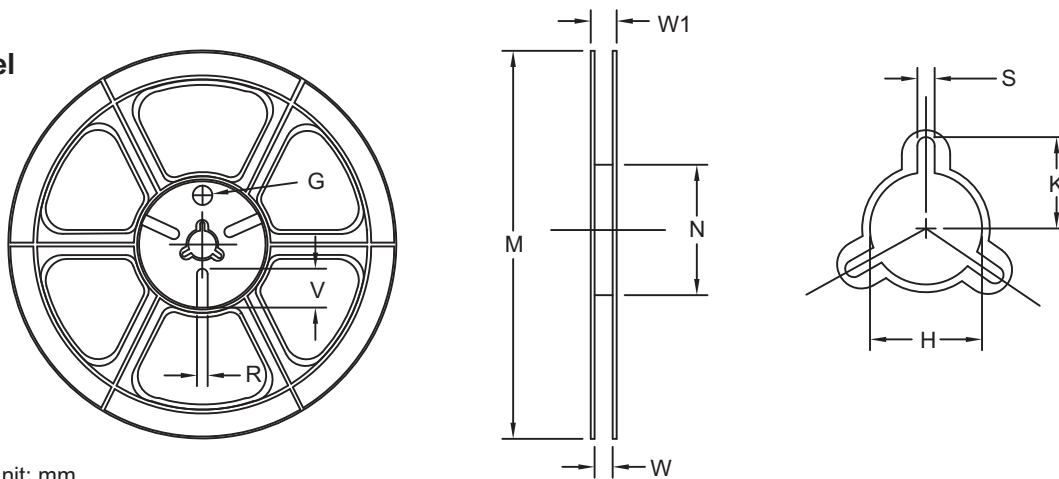

Unit: mm

Tape Size	Reel Size	M	N	W	W1	H	K	S	G	R	V
8mm	ø180	ø180.00 ±0.50	ø60.50	9.00 ±0.30	11.00 ±1.00	13.00 +0.50 / -0.20	10.60	2.00 ±0.50	ø9.00	5.00	18.00

Leader/Trailer and Orientation

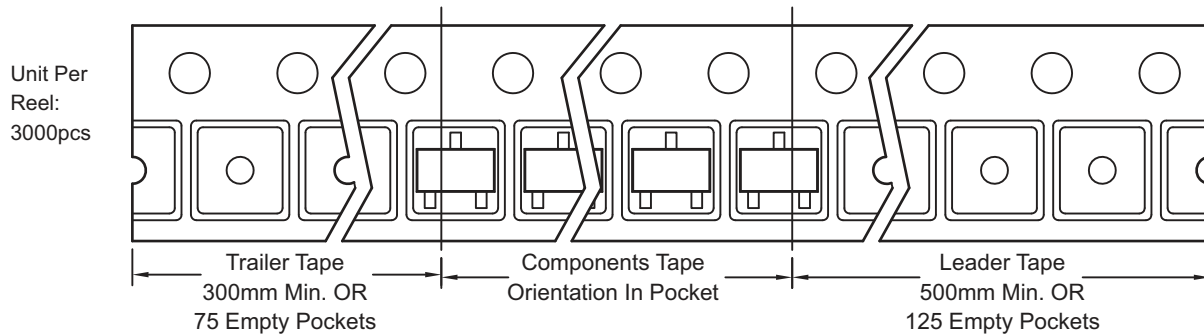

Unit Per
Reel:
3000pcs

Part Marking

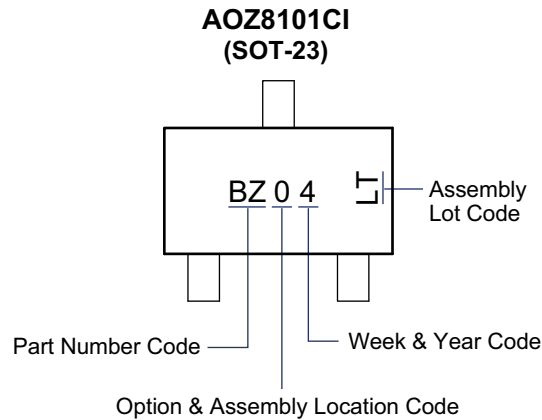

LEGAL DISCLAIMER

Alpha and Omega Semiconductor makes no representations or warranties with respect to the accuracy or completeness of the information provided herein and takes no liabilities for the consequences of use of such information or any product described herein. Alpha and Omega Semiconductor reserves the right to make changes to such information at any time without further notice. This document does not constitute the grant of any intellectual property rights or representation of non-infringement of any third party’s intellectual property rights.

LIFE SUPPORT POLICY

ALPHA AND OMEGA SEMICONDUCTOR PRODUCTS ARE NOT AUTHORIZED FOR USE AS CRITICAL COMPONENTS IN LIFE SUPPORT DEVICES OR SYSTEMS.

As used herein:

- | | |
|---|---|
| <p>1. Life support devices or systems are devices or systems which, (a) are intended for surgical implant into the body or (b) support or sustain life, and (c) whose failure to perform when properly used in accordance with instructions for use provided in the labeling, can be reasonably expected to result in a significant injury of the user.</p> | <p>2. A critical component in any component of a life support, device, or system whose failure to perform can be reasonably expected to cause the failure of the life support device or system, or to affect its safety or effectiveness.</p> |
|---|---|