

Over	Up to and including	Tolerance
0	1000	±20
1000	3000	±30
3000	5000	±40
5000	10000	±50
10000	15000	±100
15000	20000	±150
20000		±L/100

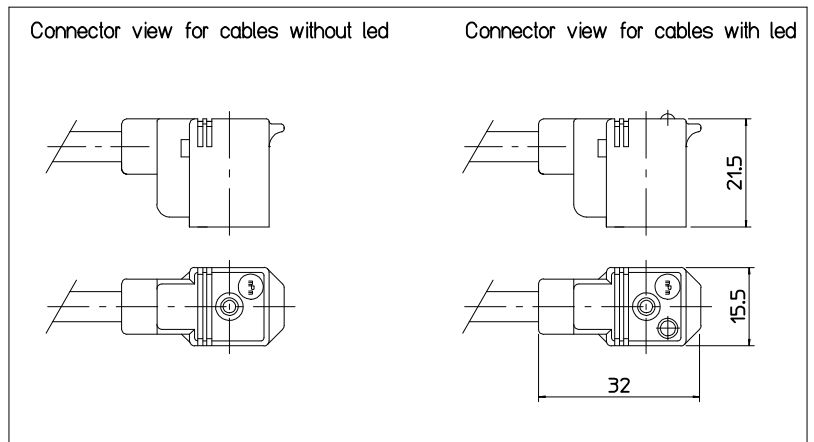

PART No MATRIX - PN KEY

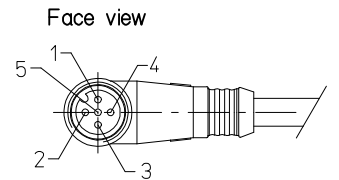
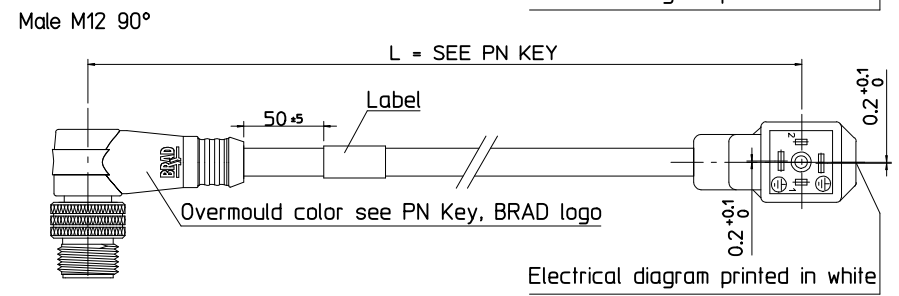
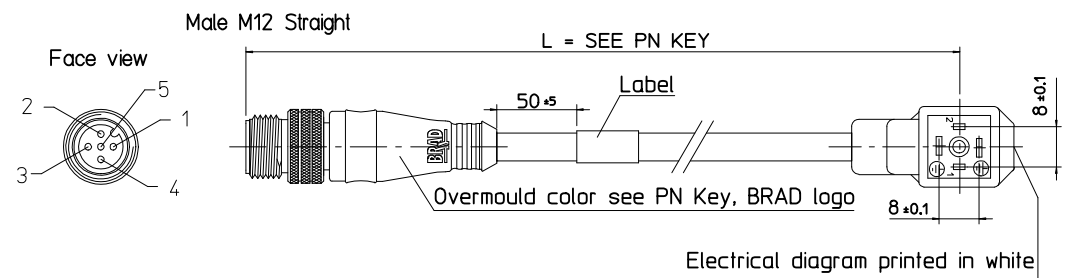
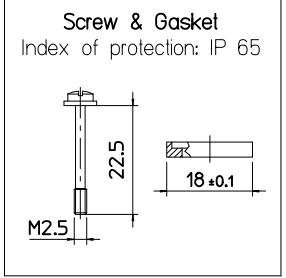
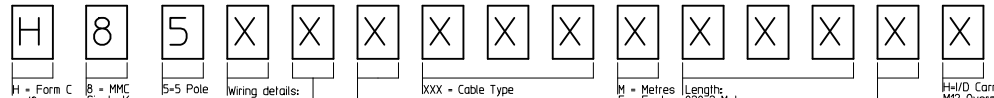

- H = Form C (8mm contact spacing)
- 8 = MMC Single Keyway
- 5 = 5-5 Pole
- Wiring details: 0 = Positive Switching (pin 3&4), 1 = Negative Switching (pin 1&4)
- Electrical configuration: 0 = Without LED/Without circuit, A = S0 24V Yellow LED, B = C4 24V Yellow LED, C = S0 110V Yellow LED, D = C4 110V Yellow LED, E = S0 24V Green LED, F = C4 24V Green LED, G = S0 110V Green LED, H = C4 110V Green LED, J = S0 24V Red LED, K = C4 24V Red LED, L = S0 110V Red LED, M = C4 110V Red LED, S = C4 230V Yellow LED
- XXX = Cable Type
- M = Metres, F = Feet
- Lengths: 00-2 Meters, 05-5 Meters, 20-20 Meters
- DIN Earth Position - o'clock & M12 connector body: 0 = Earth H6/H12, MALE Straight, 2 = Earth H6/H12, MALE 90°
- H/D Carrier M12 Overmoulding color: Blank-Black Standard, Y=Yellow, A=Grey
- Coupling Nut Material: Blank-Standard, 1=Stainless Steel, 5=Delrin, 7=Teflon coat

DRAWING UPDATE EC NO: IPG2014-0850 DRWN: JMARSZALEK 2013/11/07 CHKD: MSZWAJKOWSKI 2013/11/07 APPR: MIWASIECZKO 2013/11/08	QUALITY SYMBOLS ▽=0 ▽=0	GENERAL TOLERANCES (UNLESS SPECIFIED)		DIMENSION STYLE MM ONLY		SCALE	DESIGN UNITS	FIRST ANGLE PROJECTION		
						METRIC				
		4 PLACES ± --- ± --- 3 PLACES ± --- ± --- 2 PLACES ± --- ± --- 1 PLACE ± --- ± --- 0 PLACE ± --- ± ---		DRAWN BY: JMARSZALEK CHECKED BY: MSZWAJKOWSKI APPROVED BY: MIWASIECZKO		DATE: 2012/11/09 DATE: 2012/11/09 DATE: 2012/11/09			TITLE: H85XXXXXXXXXX DIN C + CORDSETS M12	
		ANGULAR ± --- ° DRAFT WHERE APPLICABLE MUST REMAIN WITHIN DIMENSIONS		MATERIAL NO. SEE SHEET 3		DOCUMENT NO. SD-121036-004			SHEET NO. 1 OF 3	

Electrical diagrams

Electrical diagram with circuit S0 (zener diode) for:

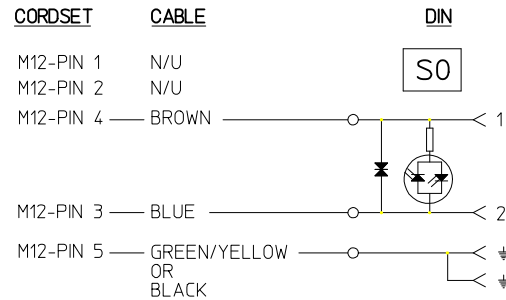

Electrical diagram with circuit C4 (VDR) for:

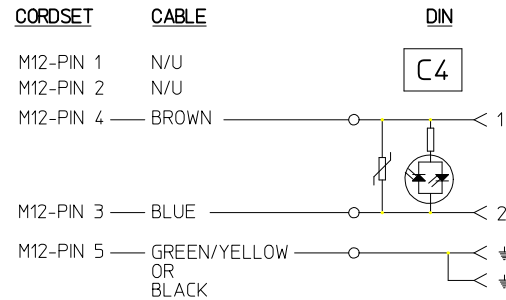

Cable type

Cable Type	Jacket Material	Jacket Color	Wire cross section	Braid
A58	PVC	Black	20AWG	no
B08	PUR	Yellow	18AWG	no
E03	PVC	Black	0.34mm ²	no
E12	PVC	Black	0.5mm ²	no
I12	CEI PVC	Grey	0.5mm ²	no
P12	PUR	Black	0.5mm ²	no
P82	PUR IRR	Orange	0.34mm ²	no
B31	PUR	Black	0.5mm ²	no



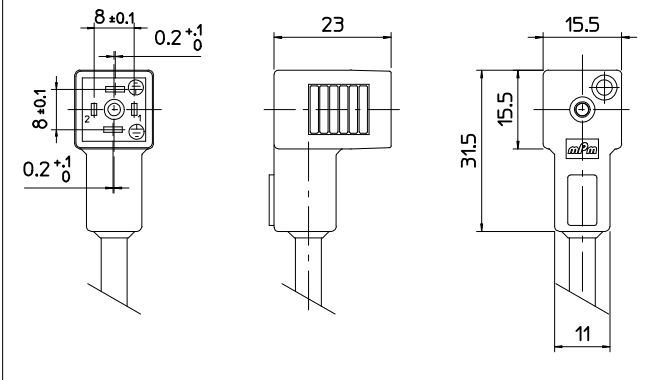

Form shape SMC for PN's with cable B08



DRAWING UPDATE EC NO: IPG2014-0850 DRWN: JMARSZALEK 2013/11/07 CHKD: MSZWAJKOWSKI 2013/11/07 APPR: MIWASIECZKO 2013/11/08	QUALITY SYMBOLS	GENERAL TOLERANCES (UNLESS SPECIFIED)	DIMENSION STYLE	SCALE	DESIGN UNITS	FIRST ANGLE PROJECTION	
	▽=0 ◻=0	mm INCH 4 PLACES ± --- ± --- 3 PLACES ± --- ± --- 2 PLACES ± --- ± --- 1 PLACE ± --- ± --- 0 PLACE ± --- ± ---	MM ONLY	1:1	METRIC		
	DESCRIPTION	ANGULAR ± --- °	DRAWN BY	DATE	TITLE		
	REV	DRAFT WHERE APPLICABLE MUST REMAIN WITHIN DIMENSIONS	JMARSZALEK	2012/11/09	H85XXXXXXXXXX DIN C + CORDSETS M12		
			CHECKED BY	DATE			
		MSZWAJKOWSKI	2012/11/09	DOCUMENT NO. SD-121036-004 SHEET NO. 2 OF 3			
		APPROVED BY	DATE	THIS DRAWING CONTAINS INFORMATION THAT IS PROPRIETARY TO MOLEX INCORPORATED AND SHOULD NOT BE USED WITHOUT WRITTEN PERMISSION			
		MIWASIECZKO	2012/11/09				

PART LIST

Pos.	Molex PN:	Engineering No.:	Pos.	Molex PN:	Engineering No.:	Pos.	Molex PN:	Engineering No.:	Pos.	Molex PN:	Engineering No.:	Pos.	Molex PN:	Engineering No.:
1	1210350169	H85000E12M006	41	1210360515	H850A0A58M050	81			121			161		
2	1210350200	H85002E12M003	42	1210360516	H850A0A58M070	82			122			162		
3	1210350222	H85000E12M003	43	1210360517	H850B0B08M006	83			123			163		
4	1210350223	H85002E12M006	44	1210360518	H850B0B08M010	84			124			164		
5	1210350327	H85000P12M010	45	1210360519	H850B0B08M030	85			125			165		
6	1210350327	H85000P12M010	46	1210360520	H850B0B08M050	86			126			166		
7	1210350328	H85002P12M010	47	1210360521	H850B0P82M010	87			127			167		
8	1210350329	H850A0P12M006	48	1210360562	H850B0P82M003	88			128			168		
9	1210350330	H850C0P12M006	49	1210360563	H850B2E12M006	89			129			169		
10	1210350331	H850A0P12M010	50	1210360564	H850B2E12M010	90			130			170		
11	1210350332	H850C0P12M010	51	1210360620	H850D0112M006	91			131			171		
12	1210350333	H850A0P12M020	52	1210360623	H850B0B08M015	92			132			172		
13	1210350334	H850C0P12M020	53	1210360624	H850B0E12M006	93			133			173		
14	1210350335	H85000P12M030	54	1210360625	H850B2E12M003	94			134			174		
15	1210350336	H850A0P12M030	55	1210360676	H850C0A58M100	95			135			175		
16	1210350350	H85000P12M011	56	1210360680	H850B0B08M100	96			136			176		
17	1210350351	H85000P12M012	57	1210360736	H850B0B08M020	97			137			177		
18	1210350351	H85000P12M012	58	1210360755	H850B2112M003	98			138			178		
19	1210350352	H85000P12M013	59	1210360760	H850K0A58M006	99			139			179		
20	1210350352	H85000P12M013	60	1210360761	H850A0A58M100	100			140			180		
21	1210350353	H85000P12M014	61	1210360767	H850B0E03M005H	101			141			181		
22	1210360291	H850B0112M006	62	1210360777	H850B2P12M020	102			142			182		
23	1210360292	H850B0112M010	63	1210360778	H850B2P12M100	103			143			183		
24	1210360293	H850B0112M020	64	1210360792	H850D0P12M006	104			144			184		
25	1210360295	H850B0P12M006	65	1210360793	H850D0P12M010	105			145			185		
26	1210360296	H850B0P12M010	66	1210360794	H850D0P12M020	106			146			186		
27	1210360305	H850B2P12M010	67	1210360812	H850B2P12M003H	107			147			187		
28	1210360392	H850B0P12M020	68	1210360832	H850B2P12M006	108			148			188		
29	1210360434	H850B0P12M050	69	1210360833	H850B2P12M015	109			149			189		
30	1210360440	H850B0P12M030	70	1210360834	H850B2P12M030	110			150			190		
31	1210360465	H850B0E12M003	71	1210360881	H850B0P12M003	111			151			191		
32	1210360467	H850B0E12M010	72	1210360882	H850B2P12M003	112			152			192		
33	1210360468	H850B0E12M020	73	1210360917	H850B0B31M006	113			153			193		
34	1210360469	H850B0E12M030	74	1210360918	H850B0B31M010	114			154			194		
35	1210360470	H850B0E12M050	75	1210360919	H850B0B31M015	115			155			195		
36	1210360471	H850B0P12M015	76	1210360920	H850B0B31M030	116			156			196		
37	1210360472	H850B2E12M020	77	1210360921	H850B2B31M006	117			157			197		
38	1210360512	H850A0A58M015	78	1210360922	H850B2B31M010	118			158			198		
39	1210360513	H850A0A58M020	79	1210360923	H850B2B31M015	119			159			199		
40	1210360514	H850A0A58M030	80	1210360924	H850B2B31M030	120			160			200		

DRAWING UPDATE EC NO: IPG2014-0850 DRWN: JMARSZALEK 2013/11/07 CHKD: MSZWAJKOWSKI 2013/11/07 APPR: MIWASIECZKO 2013/11/08	QUALITY SYMBOLS  = 0.05  = 0.1	GENERAL TOLERANCES (UNLESS SPECIFIED)		DIMENSION STYLE MM ONLY		SCALE 1:1	DESIGN UNITS METRIC	 FIRST ANGLE PROJECTION			
		4 PLACES ± --- ± --- 3 PLACES ± --- ± --- 2 PLACES ± --- ± --- 1 PLACE ± --- ± --- 0 PLACE ± --- ± ---	mm INCH	DRAWN BY JMARSZALEK	DATE 2012/11/09	TITLE H85XXXXXXXXXX DIN C + CORDSETS M12					
		ANGULAR ± --- °		CHECKED BY MSZWAJKOWSKI	DATE 2012/11/09						
		DRAFT WHERE APPLICABLE MUST REMAIN WITHIN DIMENSIONS		APPROVED BY MIWASIECZKO	DATE 2012/11/09	MATERIAL NO. SEE SHEET 3	DOCUMENT NO. SD-121036-004	SHEET NO. 3 OF 3			