

FEATURES

- Four VCAs in One Package
- Ground Referenced Current Control Inputs
- 82 dB S/N at 0.3% THD
- Full Class A Operation
- 40 dB Control Feedthrough (Untrimmed)
- Easy Signal Summing
- 6% Gain Matching

APPLICATIONS

- Electronic Musical Instruments
- Noise Gating
- Compressor/Limiters
- Signal Mixing
- Automatic Gain Control
- Voltage-Controlled Oscillators

FUNCTIONAL BLOCK DIAGRAM

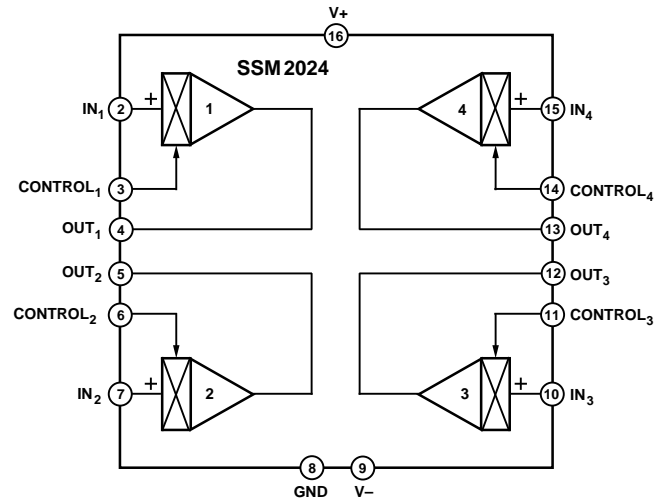

GENERAL DESCRIPTION

The SSM2024 is a quad Class A noninverting current-controlled transconductance amplifier. Each of the four VCAs is completely independent and includes a ground referenced linear current gain control. These voltage-in/current-out amplifiers offer over 82 dB S/N at 0.3% THD. Other features include low control voltage feedthrough and minimal external components for most applications. With four matched VCAs in a single IC, the SSM2024 provides a convenient solution for applications requiring multiple amplifiers. The pinout groups the four outputs for easy signal summing for circuits such as four-channel mixers.

PIN CONNECTIONS 16-Pin Plastic DIP (P Suffix)

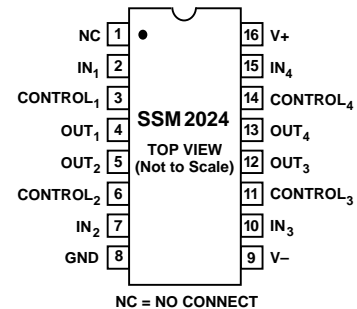

The SSM2024 is mask work protected under the Semiconductor Chip Protection Act of 1983.

REV. A

Information furnished by Analog Devices is believed to be accurate and reliable. However, no responsibility is assumed by Analog Devices for its use, nor for any infringements of patents or other rights of third parties which may result from its use. No license is granted by implication or otherwise under any patent or patent rights of Analog Devices.

SSM2024—SPECIFICATIONS

ELECTRICAL CHARACTERISTICS (@ $V_S = \pm 15\text{ V}$, $T_A = +25^\circ\text{C}$, unless otherwise noted.)

Parameter	Symbol	Conditions	SSM2024			Units
			Min	Typ	Max	
POSITIVE SUPPLY CURRENT	$+I_{SY}$	$I_{CON} (1-4) = 0$ $V_S = \pm 15\text{ V}$	0.95	1.40	1.85	mA
		$I_{CON} (1-4) = 0$ $V_S = \pm 16.5\text{ V}$	1.05	1.55	2.05	
NEGATIVE SUPPLY CURRENT	$-I_{SY}$	$I_{CON} (1-4) = 0$ $V_S = \pm 15\text{ V}$	1.05	1.55	2.05	mA
		$I_{CON} (1-4) = 0$ $V_S = \pm 16.5\text{ V}$	1.20	1.65	2.25	
GAIN	G	$I_{CON} (1-4) = \pm 500\ \mu\text{A}$	3842	4085	4330	μmhos
GAIN MATCHING	ΔG	$I_{CON} (1-4) = \pm 500\ \mu\text{A}$			± 6	%
INPUT OFFSET VOLTAGE	V_{OS}	$V_{IN} = 0\text{ V}$; $I_{CON} (1-4) = \pm 500\ \mu\text{A}$ $I_{CON} (1-4) = +250\ \mu\text{A}$		± 0.4	± 1.3	mV
CHANGE IN OFFSET VOLTAGE	ΔV_{OS}	$+2.5\ \mu\text{A} \leq I_{CON} (1-4) \leq +250\ \mu\text{A}$ $+250\ \text{nA} \leq I_{CON} (1-4) \leq +250\ \mu\text{A}$		± 100 ± 250	± 840 ± 840	μV
OUTPUT LEAKAGE	I_{OL}	$I_{CON} (1-4) = 0$		0.1	± 5	nA
CONTROL REJECTION (UNTRIMMED)	CVR	$I_{CON} (1-4) = 500\ \mu\text{A}$ $V_{IN} (1-4) = 40\ \text{mV p-p}$	30	41.5		dB
SIGNAL-TO-NOISE	S/N	$V_{IN} (1-4) = 40\ \text{mV p-p}$		82		dB
DISTORTION	THD	$V_{IN} (1-4) = 40\ \text{mV p-p}$		0.3		%
THRESHOLD INPUT CONTROL VOLTAGE	V_{TCI}	$I_{OUT} (1-4) = 0$	+160		+220	mV

Specifications subject to change without notice.

ABSOLUTE MAXIMUM RATINGS

Supply Voltage	36 V or $\pm 18\text{ V}$
Junction Temperature	$+150^\circ\text{C}$
Operating Temperature Range	-10°C to $+50^\circ\text{C}$
Storage Temperature Range	-65°C to $+150^\circ\text{C}$
Maximum Current into Any Pin	10 mA
Lead Temperature Range (Soldering, 60 sec)	$+300^\circ\text{C}$

Package Type	θ_{JA}^*	θ_{JC}	Units
14-Pin Plastic DIP (P)	90	47	$^\circ\text{C/W}$

* θ_{JA} is specified for worst case mounting conditions, i.e., θ_{JA} is specified for device in socket for P-DIP Package.

ORDERING GUIDE

Model	Temperature Range	Package Description
SSM2024P	-10°C to $+50^\circ\text{C}$	16-Pin Plastic DIP

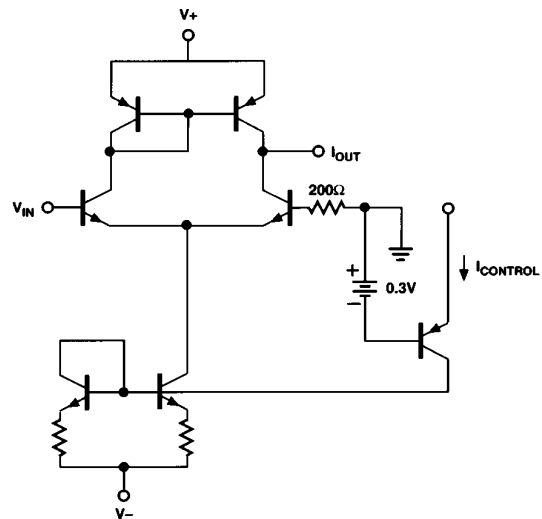

Simplified Schematic (1 of 4 Amplifiers)

THEORY OF OPERATION

The SSM2024 is a quad transconductance amplifier. Its voltage-in/current-out transfer functions are controlled by ground referenced linear current inputs. As shown in the simplified schematic, the control current is mirrored in the input stage current source. This sets the operating level for the input differential pair. The operating level established by $I_{CONTROL}$ will determine the slope of the I_{OUT}/V_{IN} transfer characteristic. Each independent device is configured as a noninverting transconductance amplifier and rated for ± 15 V operation.

SIGNAL INPUTS

The signal inputs offer the best offset and control rejection when shunted with $200\ \Omega$ to ground. This resistor along with R_{IN} form the voltage divider to scale the input signal. Select R_{IN} to set the maximum operating level for the largest input signal.

This selection will determine the VCAs operating levels which have tradeoff as shown in Figures 1 and 2. As the input signal level is increased, the effective signal-to-noise and control rejection will increase (improve). However, a larger input signal also means more THD.

The signal at the input of the device will be:

$$V_{IN}' = V_{IN} \left(\frac{200}{R_{IN} + 200} \right)$$

(where V_{IN} is the *applied* input). The circuit transconductance I_{OUT}/V_{IN}' is:

$$g_m = 8.17 I_{CONTROL} = \frac{I_{OUT}}{V_{IN}'}$$

Therefore, the output current expressed as a function of the control current and the applied input signal is:

$$I_{OUT} = 8.17 I_{CONTROL} = \left(\frac{200}{R_{IN} + 200} \right) V_{IN}$$

A graph of some typical operating levels is shown in Figure 3. Note this plot is for a general application where

$$R_{IN} = R_{CONTROL} = 10\ \text{k}\Omega$$

For output voltage vs. V_{IN} see the right axes of the graph using $R_{OUT} = 10\ \text{k}\Omega$.

CONTROL INPUTS

Each control input is a low impedance, ground referenced linear current control input. When operated in its active region, input impedance is approximately $250\ \Omega$. When operating with an applied control voltage, connect a series resistor. Select R_{CON} so $V_{CONTROL} \max/R_{CON}$ is no more than $500\ \mu\text{A}$.

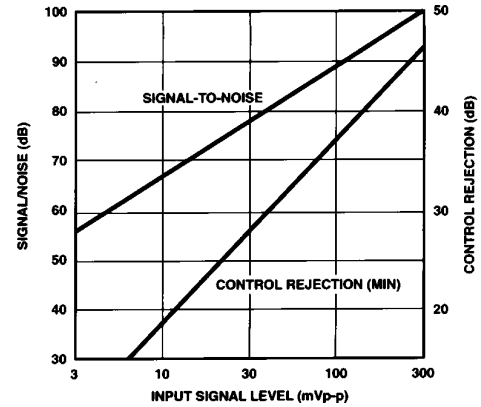

Figure 1.

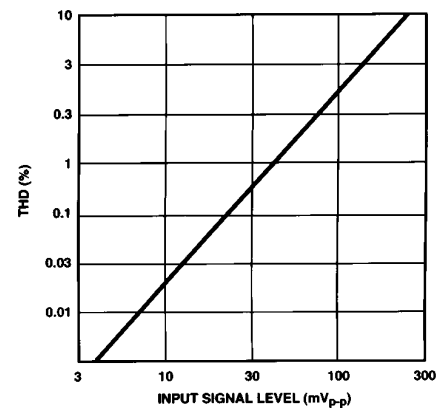

Figure 2.

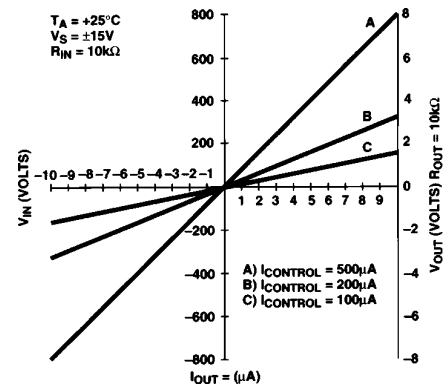

Figure 3. SSM2024 $g_m = I_{OUT}/V_{IN}$

SSM2024

The VCA will turn completely off as the control voltage drops below approximately 200 mV. The control pin can go as low as V- with no adverse effects. Control voltages usually do not exceed 10 V. It is possible to operate at higher voltages with current limiting. If the control pin is shorted directly to V+, however, the power dissipation rating of the package will be exceeded within 10 to 20 seconds.

OUTPUTS

The SSM2024 is a current output device. Operating in the current mode as virtual grounds, the outputs have a voltage compliance of only about 500 mV. For large output voltages an op amp is used as a current to voltage converter as shown in Figure 4. Selecting R_{OUT} will determine the output voltage range as

$$V_{OUT} = I_{OUT} (R_{OUT}).$$

The outputs can be used directly in many applications where voltage ranges are small, such as the exponential input of a voltage-controlled filter or other logarithmic-control voltage devices.

Outputs are conveniently located together at the center of the package for easy connections in signal summing applications.

DISTORTION

As shown in Figure 2, operation at higher signal levels will increase THD (Total Harmonic Distortion). For many applications such as control paths where a single input signal is being processed, distortion effects are minimal. This is because distortion only slightly alters the harmonic structure of a saw, pulse or triangle shaped waveform already rich in harmonics.

In the final VCA, however, where two or more signals are present, the effects of IMD (Intermodulation Distortion) become more significant. Intermodulation distortion is unwanted side-band signals produced by the circuit at frequencies that are the sums and differences of the harmonics present at the inputs.

In a Class A VCA, IMD will increase with increasing input signal level at the same rate as THD. For most applications, we recommend use of the SSM2024 at signal levels corresponding to THD of no more than 0.3% (see Figure 2).

APPLICATIONS

The following examples were developed for musical instrument applications but also illustrate general methods of use. Applications for the SSM2024 are numerous in programmable music

systems. A waveform mixer following tone sources is shown in Figure 4. This type of mixer can be configured in several ways to allow the various waveforms and tone sources to be mixed under program control. Choice of mixer configurations depends on system philosophy and the number of tone and noise sources to be considered.

The SSM2024 can also be used as the final VCA/volume and filter controls. This would make keyboard tracking and envelope sweep programmable.

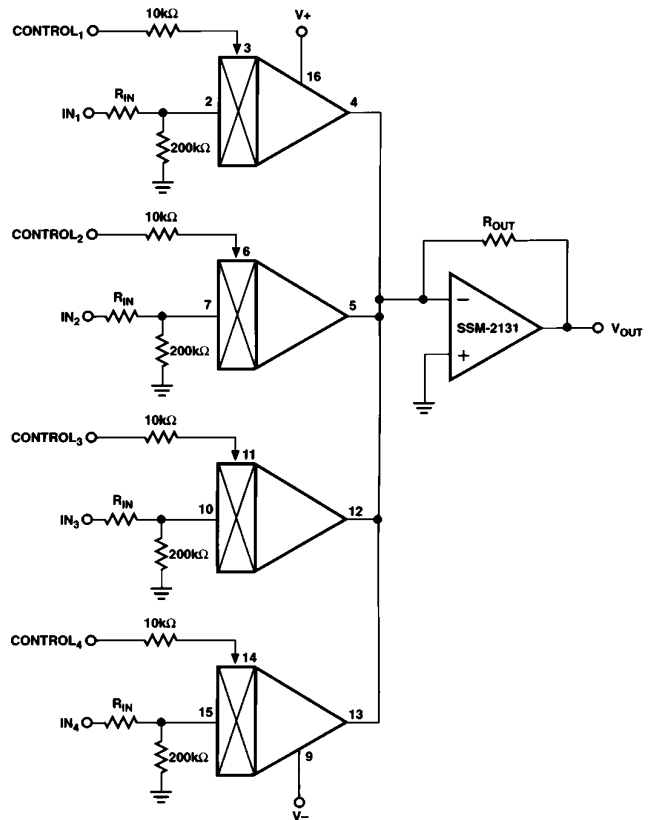

Figure 4. Four-Channel Mixer (4-1)

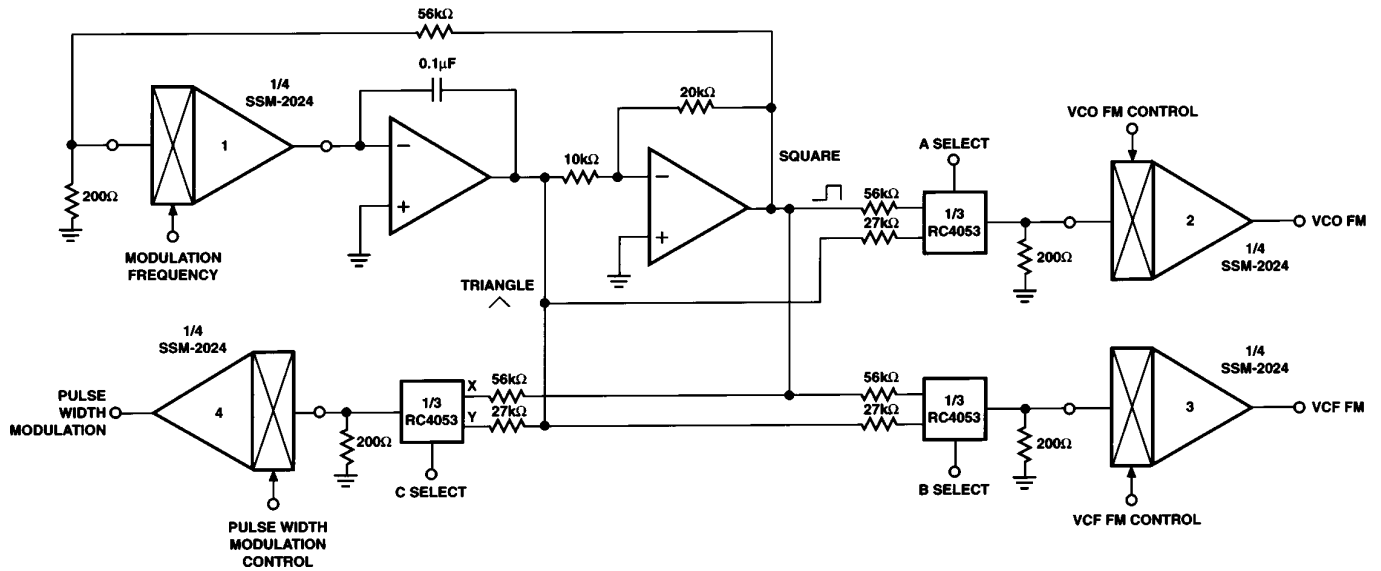
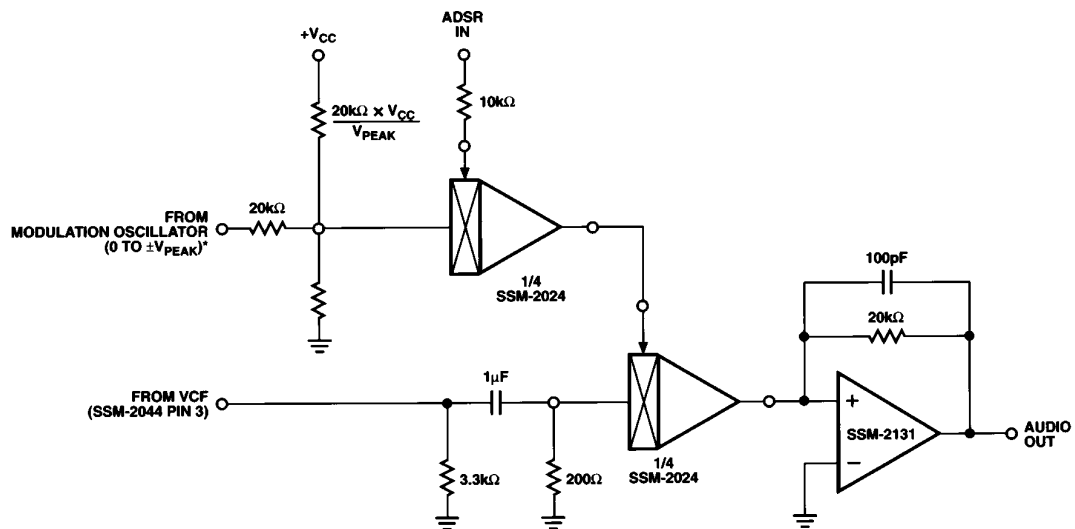

Figure 5. Modulation Oscillator

A practical modulation oscillator is shown in Figure 5. Here, the device is used in the circuit to control the oscillator frequency and the amount of modulation signal onto the modulation buses.

A VCA with programmable amplitude modulation control is shown in Figure 6. This circuit also exhibits direct interface to the SSM2044 VCF without adding an op amp or offset adjustments.



*MODULATION INCREASES FROM ZERO WITH NO INPUT TO 100% AT PEAK LEVEL.

Figure 6. VCA with Amplitude Modulation

SSM2024

Two of the SSM2024 channels can be used with the SSM2220 dual PNP transistor in an exponential cross-fade circuit. Figure 7 shows how the PNP splits a common linear control current according to the bias of the PNP pair. Here, the voltage called “exponential cross-fade control” will determine the relative amount of the two signals at the inputs of the VCAs in the mix.

The transfer characteristic of this circuit is shown in Figure 8. This plot is normalized to the balance point where each VCA has equal current (250 μA). This is plotted as the 0 dB or unity-gain point. As the control voltage is swept positive or

negative, the control current in each VCA is varied logarithmically. As the control voltage is increased, VCA B receives increased current as VCA A’s current attenuates at a more rapid logarithmic rate. This applies inversely for decreasing control voltages. At the maximum positive or negative control voltages, VCA B or VCA A receives virtually all 500 μA and is 6 dB above the balance point.

To operate a single VCA with exponential control sensitivity, simply ground the collector of the unused PNP.

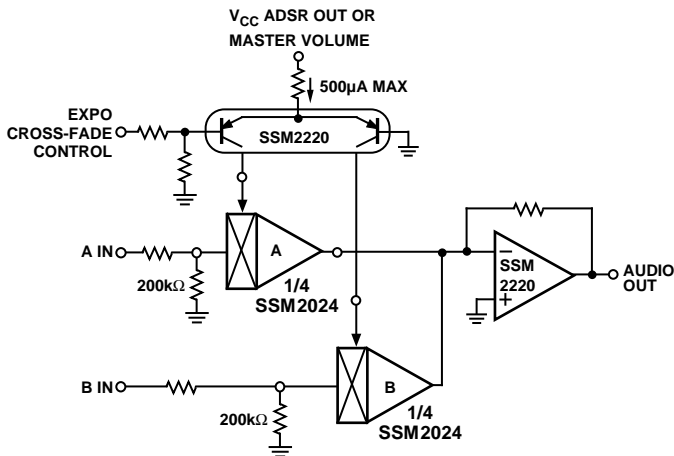

Figure 7. Exponential Cross-Fade Controller

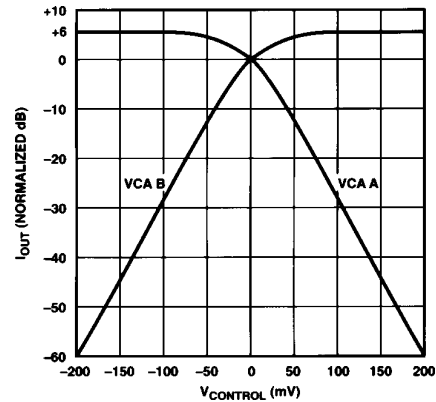

Figure 8. Normalized Transfer Characteristic of an Exponential Cross-Fade Controller

OUTLINE DIMENSIONS

Dimensions shown in inches and (mm).

16-Pin Plastic DIP (N-16)

