

Description

The AL8862Q is a step-down DC/DC converter designed to drive LEDs with a constant current. The AL8862Q operates with an input supply voltage from 5V to 55V and provides an externally adjustable output current up to 1A. Series connection of the LEDs provides identical LED currents resulting in uniform brightness and eliminating the need for ballast resistors. The AL8862Q switches at frequency up to 1MHz. This allows the use of smaller size external components, hence minimizing the PCB size.

The AL8862Q integrates the power switch and a high-side output current sensing circuit. The LED current of AL8862Q is set via an external resistor connected between the VIN and SET input pins. Dimming is achieved by applying either a DC voltage or a PWM signal at the CTRL input pin. The soft-start time can be adjusted using an external capacitor from the CTRL pin to the ground. An input voltage of 0.3V or lower at CTRL pin will shut down the power switch.

The AL8862Q includes an open-drain fault output to indicate open circuit across LED string, short-circuit across current sense resistor and overtemperature conditions.

The AL8862Q is available in SO-8EP and V-DFN3030-8/SWP (Type A) packages.

The AL8862Q is qualified to AEC-Q100 Grade 1 and is automotive grade to support PPAPs.

Features

- Wide Input Voltage Range: 5V to 55V
- Output Current up to 1A
- Internal 55V NDMOS Switch
- Typical 4% Output Current Accuracy
- Single Pin for On/Off and Brightness Control by DC Voltage or PWM Signal
- High Efficiency (Up to 97%)
- Fault Status Indication for Abnormal Operation
- LED Short-Circuit Protection
- Inherent Open-Circuit LED Protection
- Current-Sense Resistor Short-Circuit Protection
- Overtemperature Shutdown
- Up to 1MHz Switching Frequency
- SO-8EP and V-DFN3030-8/SWP (Type A) Packages Available in Green Molding Compound (No Br, Sb)
- **Totally Lead-Free & Fully RoHS Compliant (Notes 1 & 2)**
- **Halogen and Antimony Free. "Green" Device (Note 3)**
- **The AL8862Q is suitable for automotive applications requiring specific change control; this part is AEC-Q100 qualified, PPAP capable, and manufactured in IATF 16949 certified facilities.**

<https://www.diodes.com/quality/product-definitions/>

Notes: 1. No purposely added lead. Fully EU Directive 2002/95/EC (RoHS), 2011/65/EU (RoHS 2) & 2015/863/EU (RoHS 3) compliant.
 2. See <https://www.diodes.com/quality/lead-free/> for more information about Diodes Incorporated's definitions of Halogen- and Antimony-free, "Green" and Lead-free.
 3. Halogen- and Antimony-free "Green" products are defined as those which contain <900ppm bromine, <900ppm chlorine (<1500ppm total Br + Cl) and <1000ppm antimony compounds.

Pin Assignments

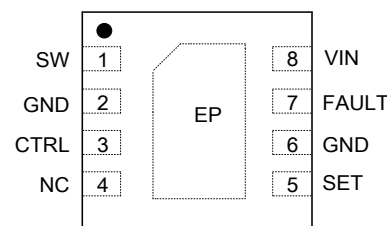
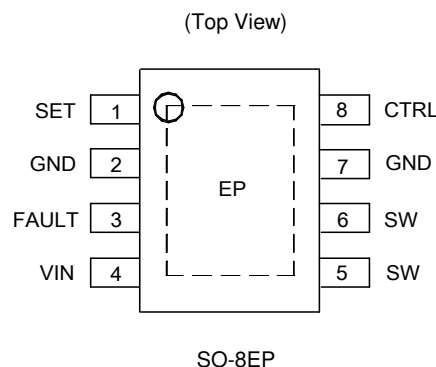

Applications

- Automotive interior LED lamps
- Automotive exterior LED lamps

Typical Applications Circuit

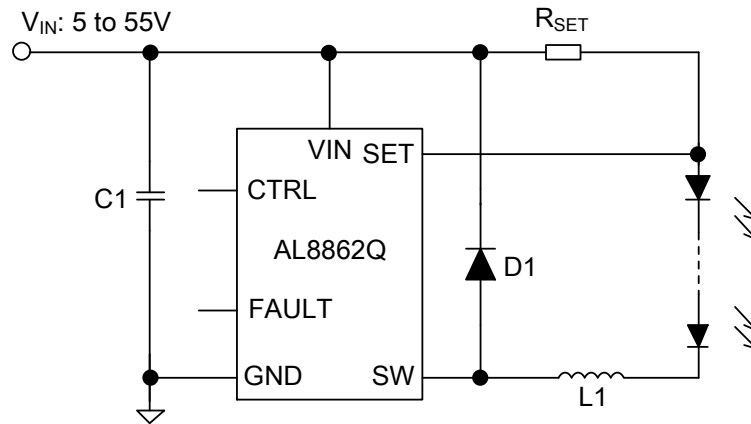

Pin Descriptions

Pin Number		Pin Name	Function
SO-8EP	V-DFN3030-8/SWP (Type A)		
1	5	SET	Set nominal output current pin. Connect resistor R _{SET} from this pin to VIN to define nominal average output current.
2, 7	2, 6	GND	Ground of IC
3	7	FAULT	FAULT indication. Asserted Low to report faulty conditions. Needs an external pullup resistor.
4	8	VIN	Input voltage (5V to 55V). Decouple to ground with 10µF or higher X7R ceramic capacitor close to device.
5, 6	1	SW	Switch pin. Connect inductor/freewheeling diode here, minimizing track length at this pin to reduce EMI.
8	3	CTRL	Multi-function On/Off and brightness control pin: <ul style="list-style-type: none"> • Leave floating for normal operation. • Drive to voltage below 0.3V to turn off output current. • Drive with DC voltage (0.4V < V_{SET} < 2.5V) to adjust output current from 10% to 100% of I_{OUT_NOM}. • Drive with an analog voltage > 2.6V output current will be 100% of I_{OUT_NOM}. • A PWM signal (Low level < 0.3V, High level > 2.6V, transition times less than 1µs) allows the output current to be adjusted over a wide range up to 100%. • Connect a capacitor from this pin to ground to increase soft-start time. (Default soft-start time = 0.1ms. Additional soft-start time is approximately 1.5ms/1nF).
—	4	NC	No connection
EP	EP	EP	Exposed pad/TAB connects to GND and thermal mass for enhanced thermal impedance.

Functional Block Diagram

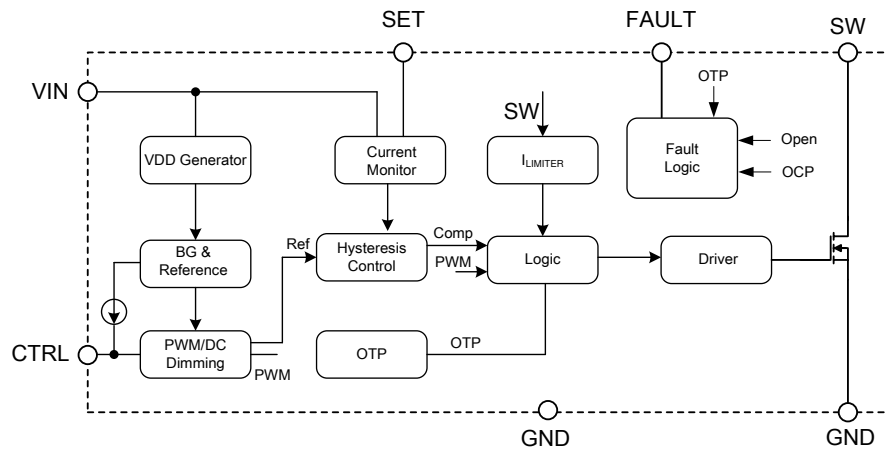

Absolute Maximum Ratings (Note 4)

Symbol	Parameter	Rating	Unit
V _{IN}	Input Voltage	-0.3 to +65	V
V _{SW} , V _{SET} , V _{FAULT}	SW, SET, FAULT Pin Voltage	-0.3 to +65	V
V _{CTRL}	CTRL Pin Input Voltage	-0.3 to +6	V
T _A	Operating Ambient Temperature	-40 to +125	°C
T _J	Operating Junction Temperature	-40 to +150	°C
T _{STG}	Storage Temperature Range	-65 to +150	°C
T _{LEAD}	Lead Temperature (Soldering, 10s)	+300	°C

Note: 4. Stresses greater than those listed under *Absolute Maximum Ratings* can cause permanent damage to the device. These are stress ratings only, and functional operation of the device at these or any other conditions beyond those indicated under *Recommended Operating Conditions* is not implied. Exposure to *Absolute Maximum Ratings* for extended periods can affect device reliability. Besides, if the voltage on CTRL pin is higher than 5V, the device will enter the test mode for parameter test. Therefore, the voltage on CTRL pin should be kept below 5V for normal operation.

ESD Ratings (Note 5)

Symbol	Parameter	Rating	Unit
V _{ESD}	Human-Body Model (HBM), per AEC-Q100-002	±3000	V
	Charged-Device Model (CDM), per AEC-Q100-011	±1000	

Note: 5. AEC-Q100-002 indicates that HBM stressing shall be in accordance with the ANSI/ESDA/JEDEC JS-001 specification.

Recommended Operating Conditions (T_A = +25°C, unless otherwise noted)

Symbol	Parameter	Min	Max	Unit
V _{IN}	Input Voltage	5	55	V
f _{SW}	Switching Frequency	—	1	MHz
I _{OUT}	Continuous Output Current	—	1	A
V _{CTRL}	Voltage Range for 10% to 100% DC Dimming Relative to GND	0.4	2.5	V
V _{CTRL_HIGH}	Voltage High for PWM Dimming Relative to GND	2.6	5	V
V _{CTRL_LOW}	Voltage Low for PWM Dimming Relative to GND	0	0.3	V
T _A	Operating Ambient Temperature	-40	+125	°C

Thermal Information (Note 6)

Symbol	Parameter	Rating	Unit
θ_{JA}	SO-8EP	58	°C/W
	V-DFN3030-8/SWP (Type A)	68.4	°C/W
θ_{JC}	SO-8EP	6.5	°C/W
	V-DFN3030-8/SWP (Type A)	16.7	°C/W

Note: 6. Device mounted on 2" x 2" FR-4 substrate PCB, 2oz copper, with minimum recommended pad layout.

Electrical Characteristics (@ $T_A = -40^\circ\text{C}$ to $+125^\circ\text{C}$, $V_{IN} = 16\text{V}$, typical values are at $T_A = +25^\circ\text{C}$, unless otherwise noted.)

Symbol	Parameter	Conditions	Min	Typ	Max	Unit
SUPPLY VOLTAGE						
V_{IN}	Input Voltage	—	5.0	—	55	V
I_Q	Quiescent Current	CTRL Pin Floating, $V_{IN} = 16\text{V}$	—	450	—	μA
V_{UVLO}	Undervoltage Lockout	V_{IN} Rising	—	4.8	—	V
V_{UVLO_HYS}	UVLO Hysteresis	—	—	200	—	mV
HYSTERESTIC CONTROL						
V_{SET}	Mean Current Sense Threshold Voltage	Measured on SET Pin with Respect to V_{IN}	96	100	104	mV
V_{SET_HYS}	Sense Threshold Hysteresis	—	—	± 13	—	%
I_{SET}	SET Pin Input Current	$V_{SET} = V_{IN} - 0.1$	—	8	—	μA
R_{SET_INT}	Internal Resistor between V_{IN} Pin and SET Pin	—	—	500	—	Ω
ENABLE AND DIMMING						
V_{CTRL}	Voltage Range on CTRL Pin	For Analog Dimming	0.4	—	2.5	V
—	Analog Dimming Range	—	10	—	100	%
V_{CTRL_ON}	DC Voltage on CTRL Pin for Analog Dimming On	V_{CTRL} Rising	—	0.45	—	V
V_{CTRL_OFF}	DC Voltage on CTRL Pin for Analog Dimming Off	V_{CTRL} Falling	—	0.40	—	V
SWITCHING OPERATION						
R_{ON}	SW Switch On Resistance	@ $I_{sw} = 100\text{mA}$	—	0.4	—	Ω
I_{SW_LEAK}	SW Switch Leakage Current	$V_{sw} = 65\text{V}$, Other Pins Floating	—	—	8	μA
t_{SS}	Soft-Start Time	$V_{IN} = 16\text{V}$, $C_{CTRL} = 1\text{nF}$	—	1.5	—	ms
f_{sw}	Operating Frequency	$V_{IN} = 16\text{V}$, $V_O = 9.6\text{V}$ (3 LEDs) $L = 47\mu\text{H}$, $\Delta I = 0.25\text{A}$ ($I_{LED} = 1\text{A}$)	—	250	—	kHz
f_{sw_MAX}	Recommended Maximum Switch Frequency	—	—	—	1	MHz
t_{ON_REC}	Recommended Minimum Switch On Time	For 4% Accuracy	—	500	—	ns
t_{PD}	Internal Comparator Propagation Delay (Note 7)	Delay Time from Triggering of Current Sense Threshold to SW On/Off	—	100	—	ns
THERMAL SHUTDOWN						
T_{OTP}	Overtemperature Protection	—	—	+150	—	°C
T_{OTP_HYS}	Temperature Protection Hysteresis	—	—	+30	—	°C
I_{SW_MAX}	Current Limit	Peak Inductor Current	—	3	—	A

Note: 7. Guaranteed by design.

Typical Performance Characteristics (@ $T_A = +25^\circ\text{C}$, $V_{IN} = 16\text{V}$, unless otherwise noted.)

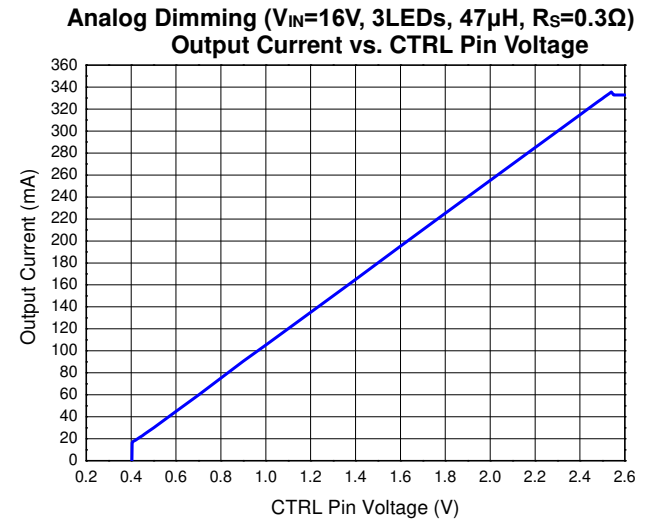
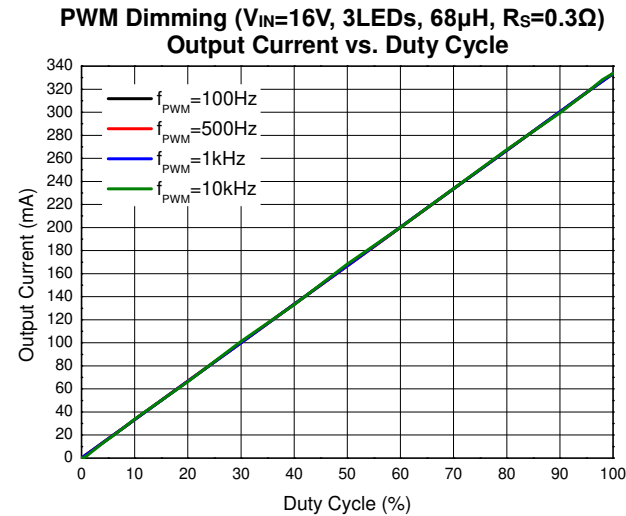
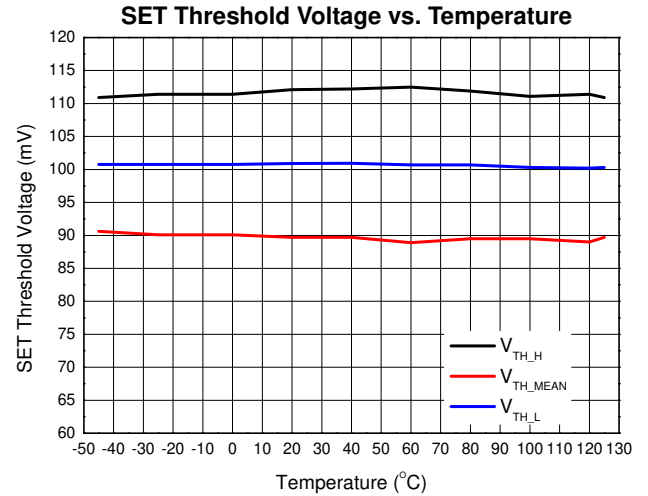
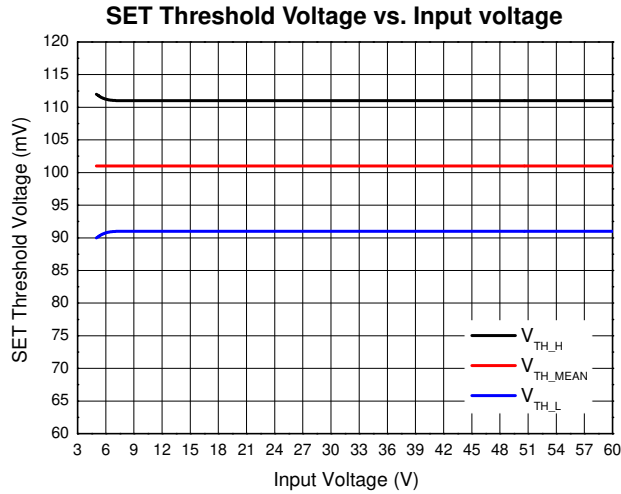
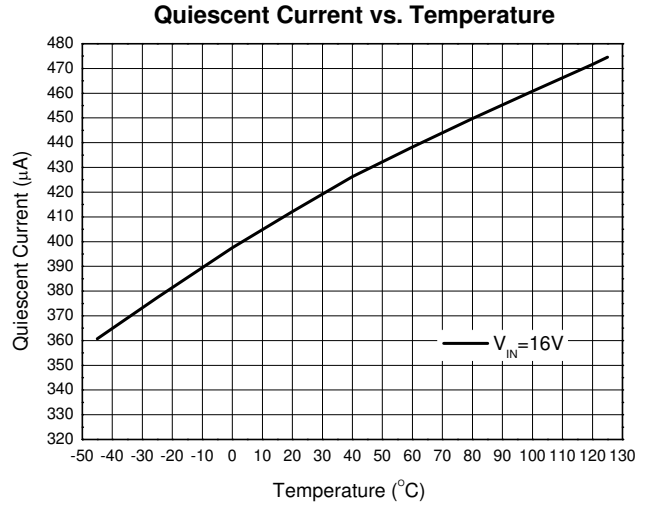
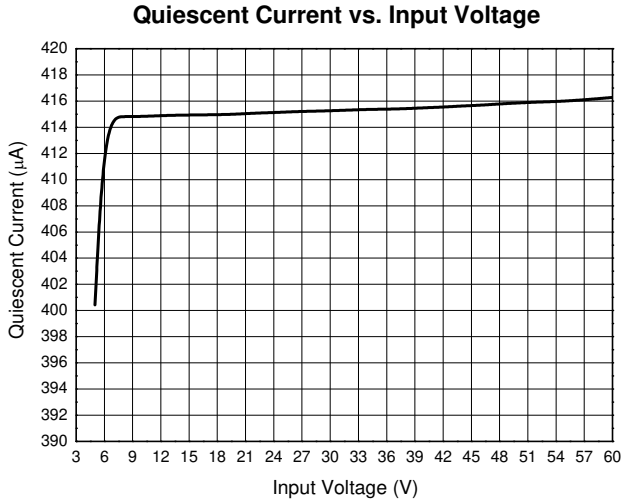

Typical Performance Characteristics (@ $T_A = +25^\circ\text{C}$, $V_{IN} = 16\text{V}$, unless otherwise noted.) (continued)

Efficiency vs. Input Voltage
($R_S=0.3\Omega$, $L=100\mu\text{H}$)

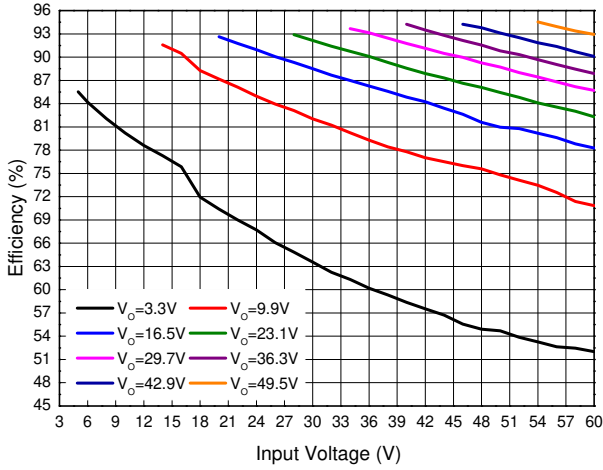

Efficiency vs. Input Voltage
($R_S=0.15\Omega$, $L=68\mu\text{H}$)

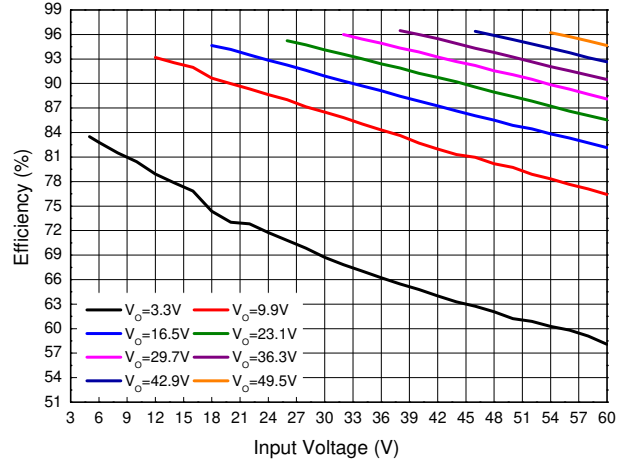

Efficiency vs. Input Voltage
($R_S=0.1\Omega$, $L=100\mu\text{H}$)

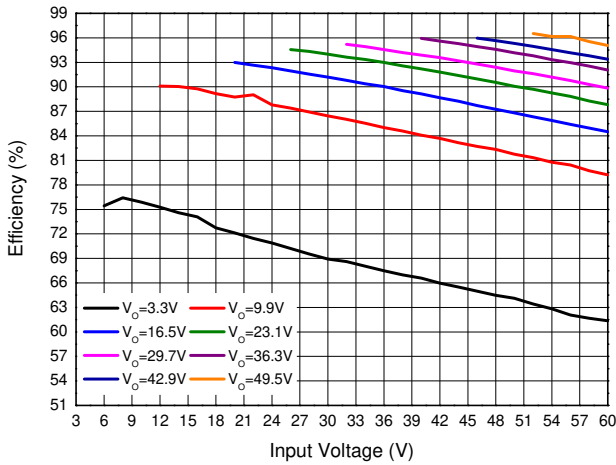

LED Current vs. Input Voltage
($R_S=0.3\Omega$, $L=100\mu\text{H}$)

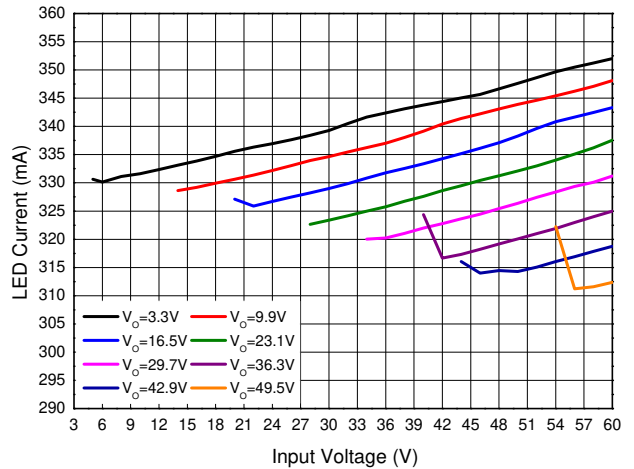

LED Current vs. Input Voltage
($R_S=0.15\Omega$, $L=68\mu\text{H}$)

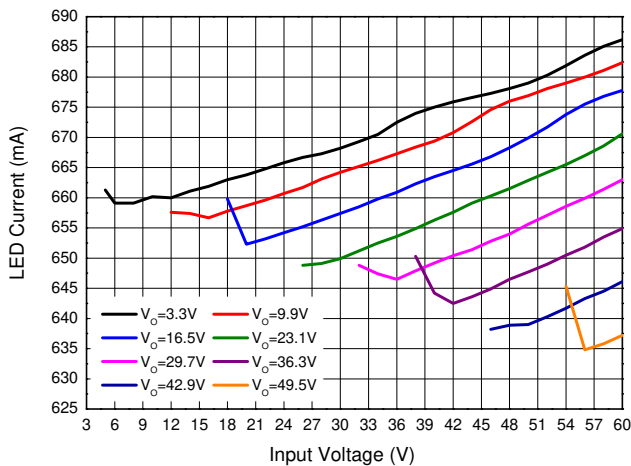

LED Current vs. Input Voltage
($R_S=0.1\Omega$, $L=100\mu\text{H}$)

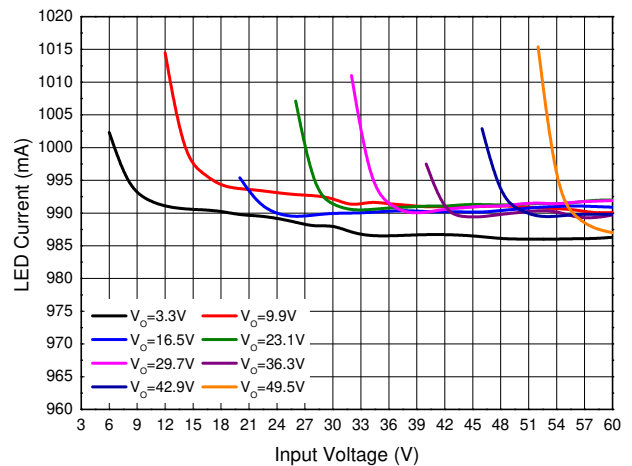

Typical Performance Characteristics (@ $T_A = +25^\circ\text{C}$, $V_{IN} = 16\text{V}$, unless otherwise noted.) (continued)

Operating Frequency vs. Input Voltage
($R_S=0.3\Omega$, $L=100\mu\text{H}$)

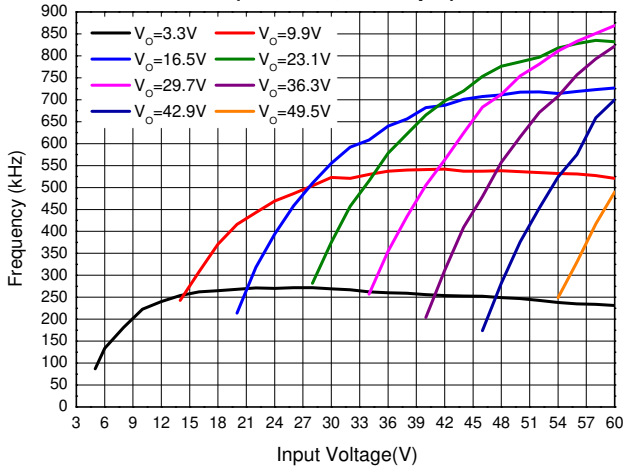

Operating Frequency vs. Input Voltage
($R_S=0.15\Omega$, $L=68\mu\text{H}$)

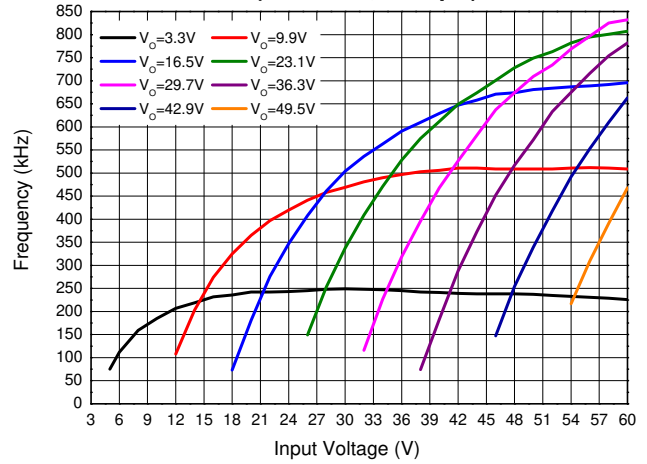

Operating Frequency vs. Input Voltage
($R_S=0.1\Omega$, $L=100\mu\text{H}$)

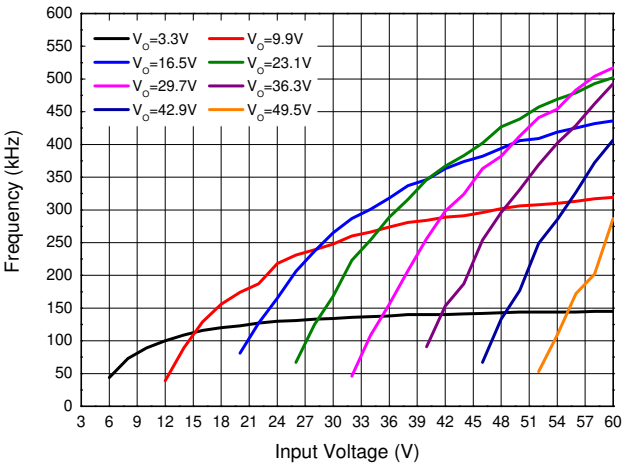

LED Current vs. Output Voltage
($R_S=0.3\Omega$, $L=100\mu\text{H}$)

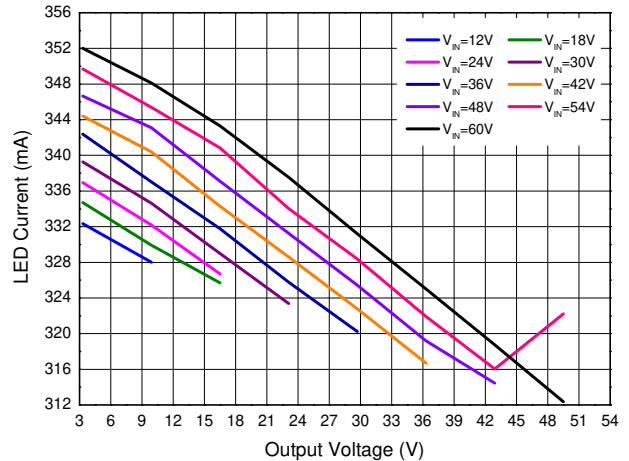

LED Current vs. Output Voltage
($R_S=0.15\Omega$, $L=68\mu\text{H}$)

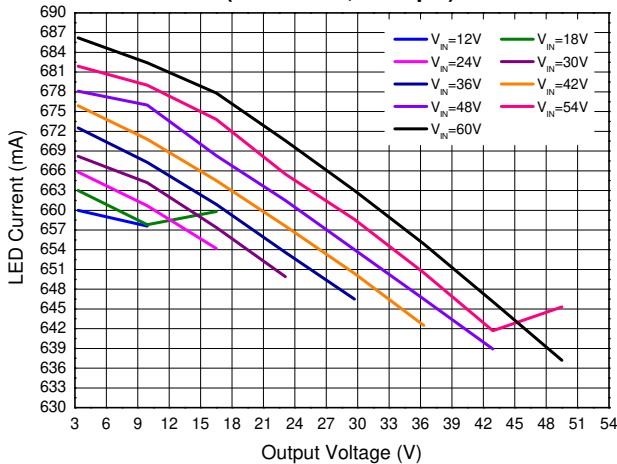

LED Current vs. Output Voltage
($R_S=0.1\Omega$, $L=100\mu\text{H}$)

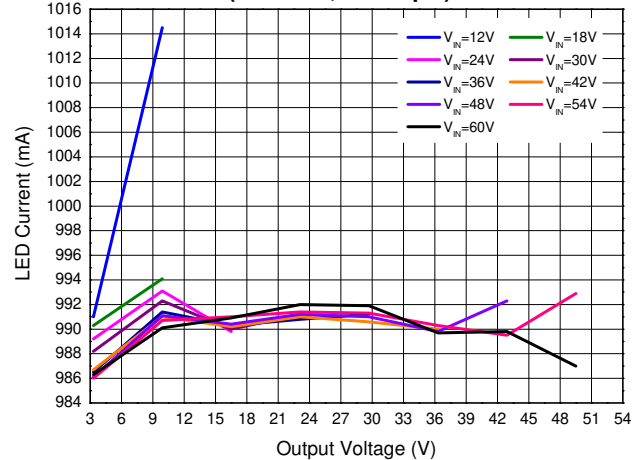

Typical Performance Characteristics (@ $T_A = +25^\circ\text{C}$, $V_{IN} = 16\text{V}$, unless otherwise noted.) (continued)

Steady Operation Waveform
($V_{LED}=9\text{V}$, $R_S=0.3\Omega$, $L=47\mu\text{H}$)

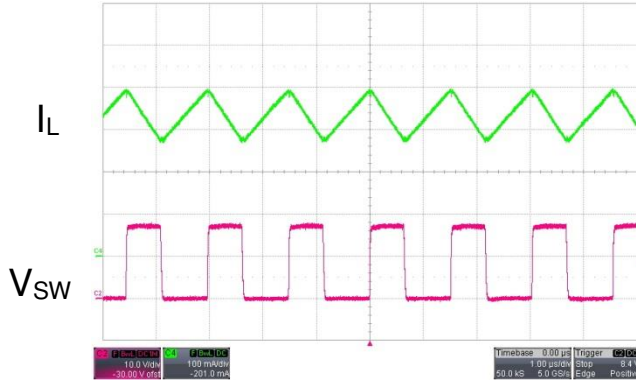

Startup Delay Time
($V_{LED}=9\text{V}$, $R_S=0.3\Omega$, $L=47\mu\text{H}$)

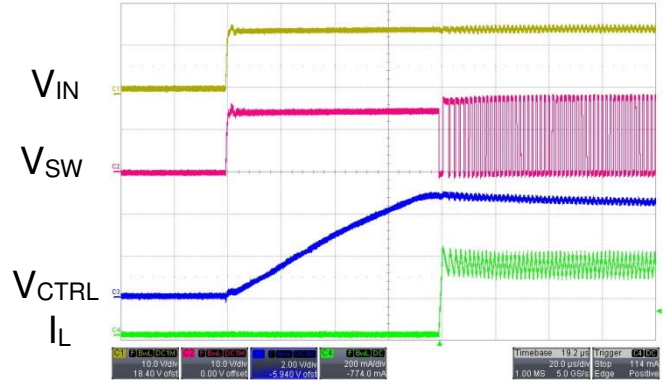

PWM Dimming (100Hz 50% Duty Cycle)
($V_{LED}=9\text{V}$, $R_S=0.3\Omega$, $L=47\mu\text{H}$)

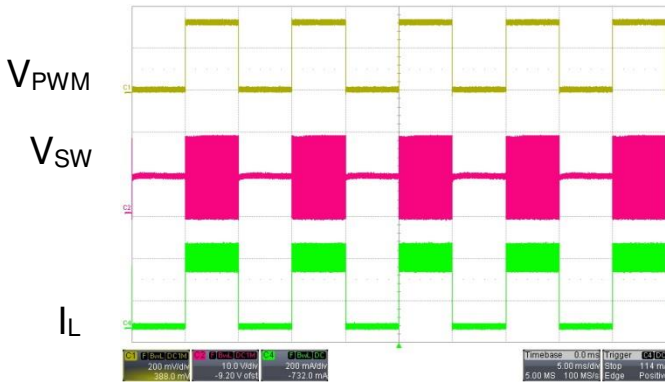

LED Open
($V_{LED}=9\text{V}$, $R_S=0.3\Omega$, $L=47\mu\text{H}$)

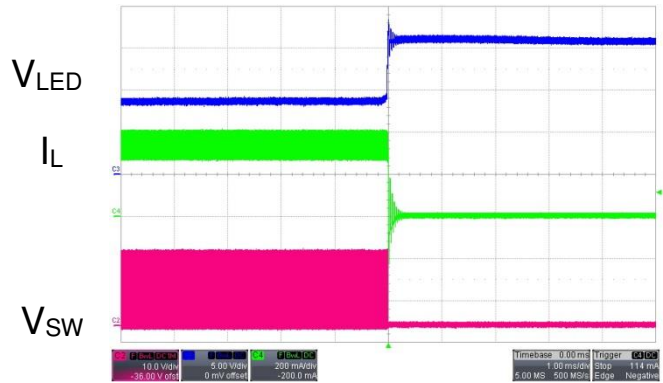

R_S Short
($V_{LED}=9\text{V}$, $R_S=0.3\Omega$, $L=47\mu\text{H}$)

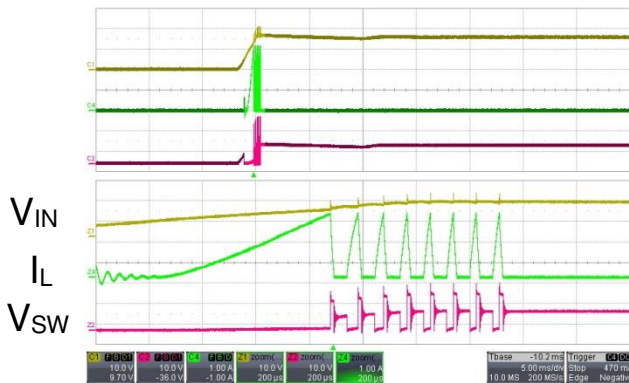

Application Information

AL8862Q Operation

In normal operation, when normal input voltage is applied at VIN pin, the AL8862Q internal switch will turn on. Current starts to flow through the sense resistor RSET, inductor L1, and the LEDs. The current ramps up linearly, and the ramp-up rate is determined by the input voltage VIN, VOUT and the inductor L1.

This rising current produces a voltage ramp across RSET. The internal circuit of the AL8862Q senses the voltage across RSET and applies a proportional voltage to the input of the internal comparator. When this voltage reaches an internal upper-set threshold, the internal switch is turned off. The inductor current continues to flow through RSET, L1, LEDs and diode D1, and back to the supply rail, but it decays with the rate determined by the forward voltage drop of LEDs and the diode D1.

This decaying current produces a falling voltage on RSET, which is sensed by the AL8862Q. A voltage proportional to the sense voltage across RSET will be applied at the input of internal comparator. When this voltage falls to the internal lower-set threshold, the internal switch is turned on again.

This switch-on-and-off cycle continues to provide the average LED current set by the sense resistor RSET.

LED Current Configuration

The nominal average output current in the LED(s) is determined by the value of the external current sense resistor (RSET) connected between VIN pin and SET pin, and is given by:

$$I_{OUT(NOM)} = \frac{0.1}{R_{SET} // R_{SET_INT}} = \frac{0.1}{R_{SET} // 500}$$

If the RSET < 1Ω, the current setting equation is simplified as below:

$$I_{OUT(NOM)} = \frac{0.1}{R_{SET}}$$

The table below gives values of the nominal average output current for setting resistor (RSET) in the *Typical Applications Circuit* shown on page 2.

RSET (Ω)	Nominal Average Output Current (mA)
0.1	1000
0.15	667
0.3	333

The above values assume that the CTRL pin is floating and at a nominal reference voltage for internal comparator. It is possible to use different values of RSET if the CTRL pin is driven by an external dimming signal.

Analog Dimming

Applying a DC voltage from 0.4V to 2.5V on CTRL pin can adjust output current from 10% to 100% of IOUT_NOM linearly, as shown in Figure 1. If the CTRL pin is brought higher than 2.5V, the LED current will be clamped to 100% of IOUT_NOM, and the output switch will turn off if the CTRL voltage falls below 0.3V.

PWM Dimming

The LED current can be adjusted digitally by applying a low frequency Pulse-Width-Modulated (PWM) logic signal to the CTRL pin to turn the device on and off. This will produce an average output current proportional to the duty cycle of the control signal. To achieve a high resolution, the PWM frequency is recommended to be lower than 500Hz, however high dimming frequencies can be used, at the expense of dimming dynamic range and accuracy. Typically, for a PWM frequency of 500Hz, the accuracy is better than 1% for PWM ranging from 1% to 100%.

The accuracy of the low duty cycle dimming is affected by both the PWM frequency and the switching frequency of the AL8862Q. For best accuracy/resolution, the switching frequency should be increased while the PWM frequency should be reduced.

The CTRL pin is designed to be driven by both 3.3V and 5V logic levels directly from a logic output with either an open drain output or a push-pull output stage.

Application Information (continued)

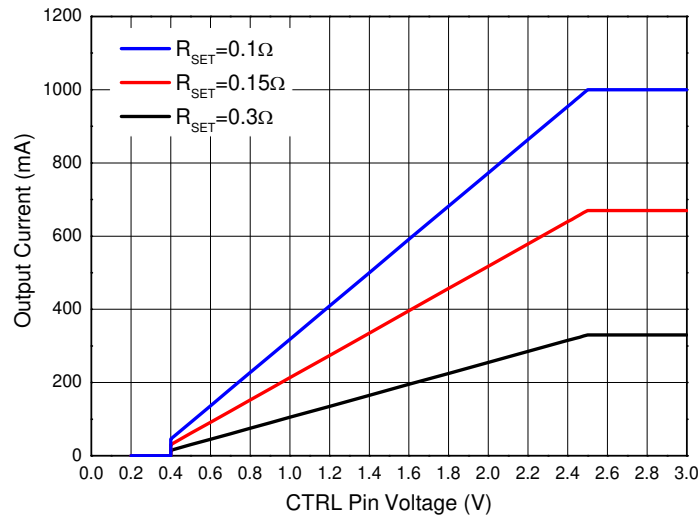

Figure 1. Analog Dimming Curve

Soft-Start

The default soft-start time for the AL8862Q is 0.1ms – this provides very fast turn-on of the output, improving the PWM dimming accuracy.

Nevertheless, adding an external capacitor from the CTRL pin to ground will provide a longer soft-start delay. This is achieved by increasing the time for the CTRL voltage rising to the turn-on threshold and by slowing down the rising rate of the control voltage at the input of hysteresis comparator. The additional soft-start time is related to the capacitance between CTRL pin and GND, the typical value will be 1.5ms/nF.

Capacitor Selection

A low ESR capacitor should be used for input decoupling, as the ESR of this capacitor appears in series with the supply source impedance and will reduce the overall efficiency. This capacitor can supply the relatively high peak current to the coil and smooth the ripple on the input current.

The minimum capacitance needed is determined by input power, cable’s length and peak current. 4.7µF to 10µF is a common used value range for most of cases. A higher value will improve performance at lower input voltages, especially when the source impedance is high. The input capacitor should be placed as close as possible to the IC.

For maximum stability over temperature and voltage, capacitors with X7R, X5R, or better dielectric are recommended. Capacitors with Y5V dielectric are not suitable for decoupling in this application and should NOT be used.

Freewheel Diode Selection

For maximum efficiency and performance, the freewheeling diode (D1) should be a fast low capacitance Schottky diode with low reverse leakage current. It also provides better efficiency than silicon diodes, due to the lower forward voltage and reduced recovery time.

It is important to select parts with a peak current rating above the peak coil current and a continuous current rating higher than the maximum output load current. It is very important to control the reverse leakage current of the diode when operating above +85°C. Excess leakage current will increase power dissipation.

The higher forward voltage and overshoot due to reverse recovery time in silicon diodes will increase the peak output voltage on the SW pins. If a silicon diode is used, more care should be taken to ensure that the total voltage appearing on the SW pins including supply ripple, will not exceed the specified maximum value.

Application Information (continued)

Inductor Selection

Recommended inductor value for the AL8862Q is in the range of 33μH to 100μH. Higher inductance is recommended at higher supply voltages in order to minimize output current tolerance due to switching delays, which will result in increased ripple and lower efficiency. Higher inductance also results in a better line regulation. The inductor should be mounted as close to the device as possible with low resistance connections to SW pins.

The chosen coil should have saturation current higher than the peak output current and a continuous current rating above the required mean output current.

The inductor value should be chosen to maintain operating duty cycle and switch 'on'/'off' times within the specified limits over the supply voltage and load current range. The following equations can be used as a guide.

SW Pins Switch 'On' Time

$$t_{ON} = \frac{L\Delta I}{V_{IN} - V_{LED} - I_{LED}(R_{SET} + R_L + R_{sw})}$$

SW Pins Switch 'Off' Time

$$t_{OFF} = \frac{L\Delta I}{V_{LED} + V_D + I_{LED}(R_{SET} + R_L)}$$

Where: L is the coil inductance; RL is the coil resistance; RSET is the current sense resistance; ILED is the required LED current; ΔI is the coil peak-peak ripple current (Internally set to 0.26 x ILED); VIN is the supply voltage; VLED is the total LED forward voltage; Rsw is the switch resistance (0.55Ω nominal); VD is the diode forward voltage at the required load current.

Thermal Protection

The AL8862Q includes Overtemperature Protection (OTP) circuitry that will turn off the device if its junction temperature gets too high. This is to protect the device from excessive heat damage. The OTP circuitry includes thermal hysteresis that will cause the device to restart normal operation once its junction temperature has cooled down by approximately +30°C.

Open-Circuit LED Protection

The AL8862Q has default open LED protection. If the LEDs become open circuit, the AL8862Q will stop oscillating; the voltage at the SET pin will rise to VIN and the voltage at the SW pin will then fall to GND. No excessive voltages will be seen with the AL8862Q.

LED Short-Circuit Protection

If the LED string becomes shorted together (the anode of the top LED becomes shorted to the cathode of the bottom LED), the AL8862Q will continue to switch and the current through the AL8862Q's internal switch will still be at the expected current – so no excessive heat will be generated within the AL8862Q. However, the duty cycle will change dramatically and the switching frequency will most likely decrease. See Figure 2 for an example of this behavior at 24V input voltage driving 3 LEDs.

The on-time of the internal power MOSFET switch is significantly reduced because almost all of the input voltage is now developed across the inductor. The off-time is significantly increased because the reverse voltage across the inductor is now just the Schottky diode voltage (See Figure 2) causing a much slower decay in inductor current.

Application Information (continued)

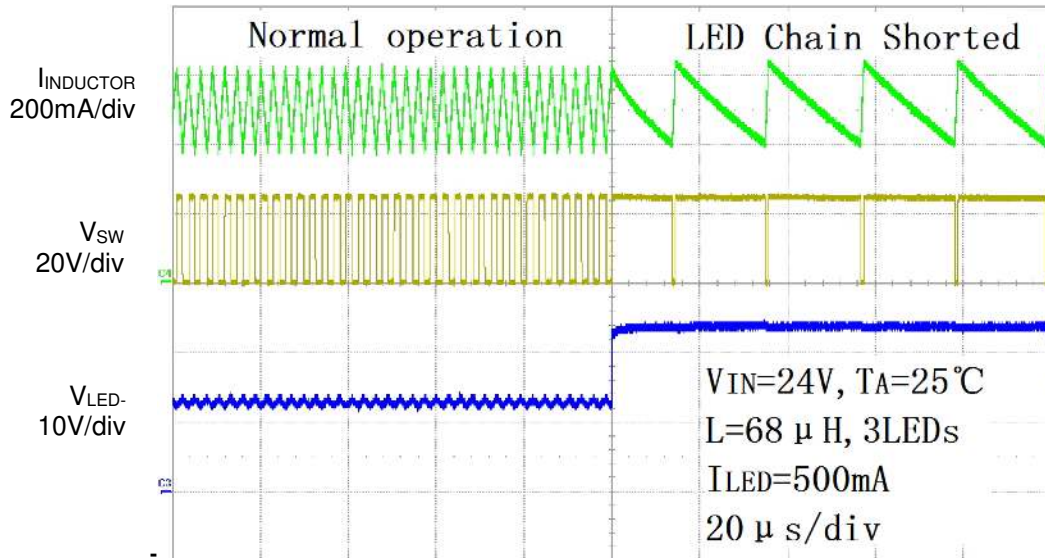

Figure 2. Switching Characteristics (Normal Operation to LED String Shorted)

Current Sense Resistor Short-Circuit Protection

The AL8862Q has an internal current limit at about 3A. If current-sense resistor R_{SET} is shorted, current limit is triggered for accumulated 8 times and the switch will shut down and latch off. Only a power cycle of V_{IN} can reset AL8862Q.

Fault Indicator

The AL8862Q includes an active low, open-drain fault indicator (FAULT). The FAULT pin goes low when one of the following conditions occurs:

- 1) Open circuit across LED string
- 2) Short circuit across current sense resistor
- 3) Overtemperature condition

Fault	Detection	Action
Open-Circuit across LED String	SW < 0.6V lasts for 100μs	When open circuit occurs, the resulted voltage drop on sensing resistor is nearly zero and the SW pin output will be constantly low, leading to output voltage V_{OUT} equals V_{IN} . No excessive voltages will be seen with the AL8862Q and external components. If open-circuit condition lasts for accumulated 100μs, FAULT goes low. The AL8862Q resumes normal operation and FAULT resumes high once fault condition is removed.
Short Circuit across Current Sense Resistor	Current limit is triggered for 8 times	When current sense resistor is short circuited, the AL8862Q will continue to switch and the inductor current will continue to go up until the internal current limit of 3A is reached. If the current limit is triggered for 8 times, the system is latched off and FAULT goes low and will remain low until the power is cycled.
Overtemperature Condition	$T_J > +150^{\circ}C$	When the junction temperature exceeds approximately $+150^{\circ}C$, the AL8862Q is forced to shut down and FAULT goes low. A startup sequence is initiated and FAULT resumes high when the junction temperature drops by $+30^{\circ}C$.

Application Information (continued)

EMI and Layout Considerations

The AL8862Q is a switching regulator with fast edges and measures small differential voltages; as a result of this, care has to be taken with decoupling and layout of the PCB. To help with these effects, the AL8862Q has been developed to minimize radiated emissions by controlling the switching speeds of the internal power MOSFET. The rise and fall times are controlled to get the right compromise between power dissipation due to switching losses and radiated EMI. The turn-on edge (falling edge) dominates the radiated EMI which is due to an interaction between the Schottky diode (D1), switching MOSFET and PCB tracks. After the Schottky diode reverse recovery time of around 5ns has occurred, the falling edge of the SW pin sees a resonant loop between the Schottky diode capacitance and the track inductance, L_{TRACK} . See Figure 3.

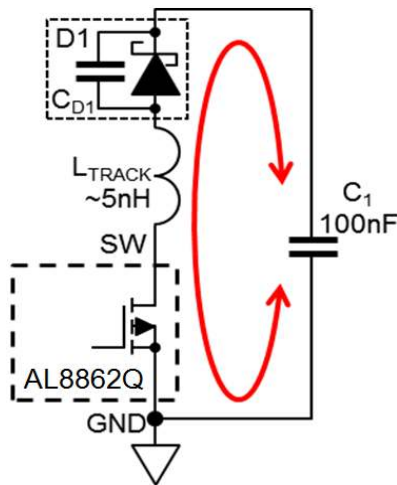

Figure 3. PCB Loop Resonance

The tracks from the SW pin to the anode of the Schottky diode, D1, and then from D1's cathode to the decoupling capacitors C1 should be as short as possible. There is an inductance internally in the AL8862Q which can be assumed to be around 1nH. For PCB tracks a figure of 0.5nH per mm can be used to estimate the primary resonant frequency. If the track is capable of handling 1A, increasing the thickness will have a minor effect on the inductance and length will dominate the size of the inductance. The resonant frequency of any oscillation is determined by the combined inductance in the track and the effective capacitance of the Schottky diode.

Recommendations for minimizing radiated EMI and other transients and thermal considerations are:

1. The decoupling capacitor (C1) has to be placed as close as possible to the VIN pin and D1 cathode.
2. The freewheeling diode's (D1) anode, the SW pin and the inductor have to be placed as close as possible to each other to avoid ringing.
3. The Ground return path from C1 must be a low impedance path with the ground plane as large as possible.
4. The LED current sense resistor (R_{SET}) has to be placed as close as possible to the VIN and SET pins.
5. The majority of the conducted heat from the AL8862Q is through the GND pin 7. A maximum earth plane with thermal vias into a second earth plane will minimize self-heating.
6. To reduce emissions via long leads on the supply input and LEDs, low RF impedance capacitors should be used at the point where the wires are joined to the PCB.

Ordering Information

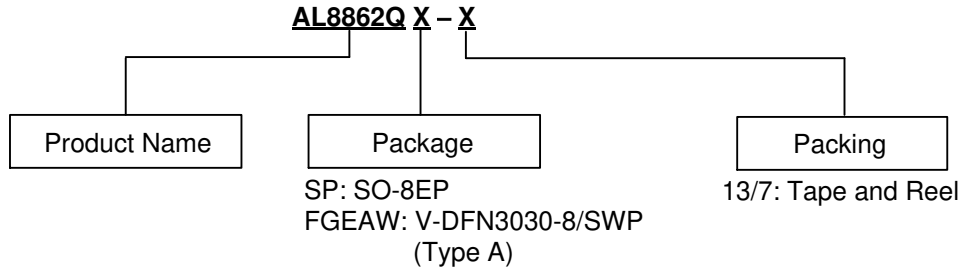

Part Number	Part Number Suffix	Package Code	Package	Packing	
				Qty.	Carrier
AL8862QSP-13	-13	SP	SO-8EP	2500	Tape & Reel
AL8862QFGEAW-7	-7	FGEAW	V-DFN3030-8/SWP (Type A)	1500	Tape & Reel

Marking Information

SO-8EP Package

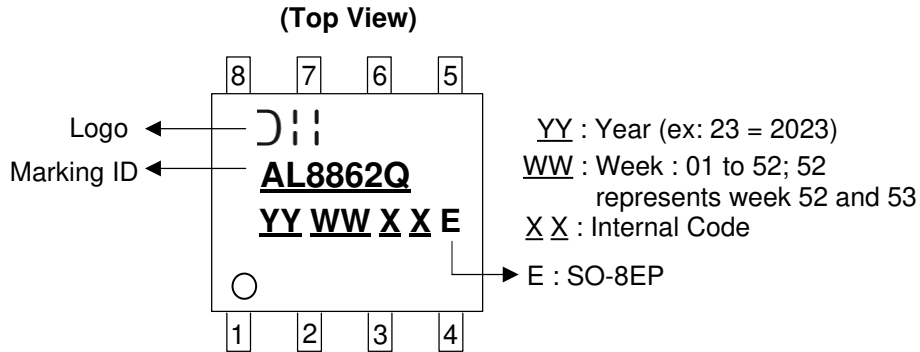

V-DFN3030-8/SWP (Type A) Package

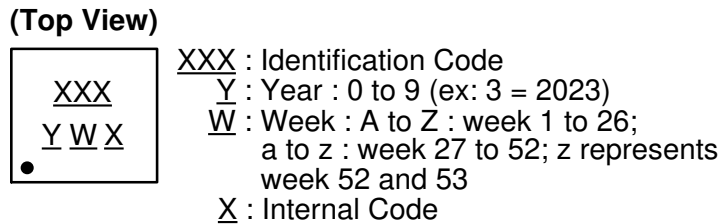

Part Number	Package	Identification Code
AL8862QFGEAW-7	V-DFN3030-8/SWP (Type A)	R8Q

Package Outline Dimensions

Please see <http://www.diodes.com/package-outlines.html> for the latest version.

SO-8EP

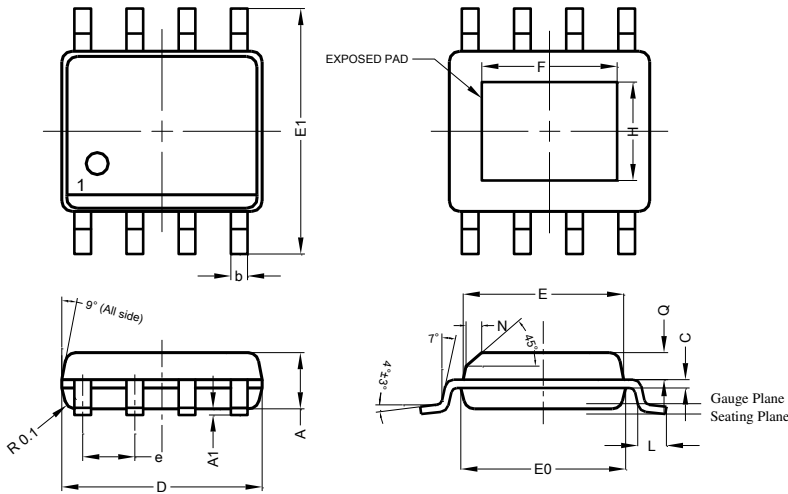

SO-8EP			
Dim	Min	Max	Typ
A	1.40	1.50	1.45
A1	0.00	0.13	-
b	0.30	0.50	0.40
C	0.15	0.25	0.20
D	4.85	4.95	4.90
E	3.80	3.90	3.85
E0	3.85	3.95	3.90
E1	5.90	6.10	6.00
e	-	-	1.27
F	2.75	3.35	3.05
H	2.11	2.71	2.41
L	0.62	0.82	0.72
N	-	-	0.35
Q	0.60	0.70	0.65
All Dimensions in mm			

V-DFN3030-8/SWP (Type A)

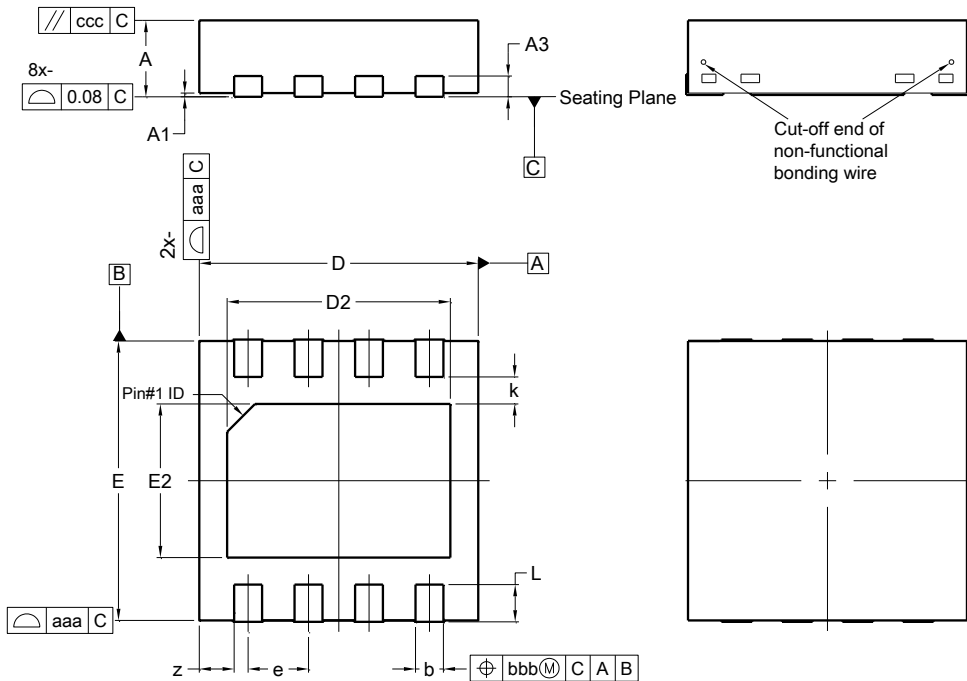

V-DFN3030-8/SWP (Type A)			
Dim	Min	Max	Typ
A	0.77	0.87	0.82
A1	0.00	0.05	0.03
A3	--	--	0.203
b	0.25	0.35	0.30
D	2.95	3.05	3.00
D2	2.30	2.50	2.40
e	0.65 BSC		
E	2.95	3.05	3.00
E2	1.55	1.75	1.65
k	--	--	0.29
L	0.35	0.45	0.40
z	--	--	0.375
aaa	0.25		
bbb	0.10		
ccc	0.10		
All Dimensions in mm			

Suggested Pad Layout

Please see <http://www.diodes.com/package-outlines.html> for the latest version.

SO-8EP

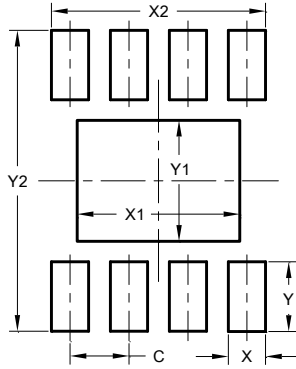

Dimensions	Value (in mm)
C	1.270
X	0.802
X1	3.502
X2	4.612
Y	1.505
Y1	2.613
Y2	6.500

V-DFN3030-8/SWP (Type A)

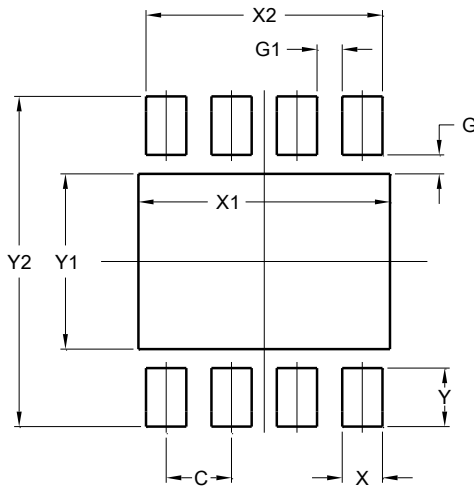

Dimensions	Value (in mm)
C	0.650
G	0.190
G1	0.250
X	0.400
X1	2.500
X2	2.350
Y	0.585
Y1	1.750
Y2	3.300

Mechanical Data

SO-8EP

- Moisture Sensitivity: Level 1 per JESD22-A113
- Terminals: Finish - Matte Tin Plated Leads, Solderable per M2003 JESD22-B102 (e3)
- Weight: 0.081 grams (Approximate)

V-DFN3030-8/SWP (Type A)

- Moisture Sensitivity: Level 1 per J-STD-020
- Terminals: Finish – Matte Tin Plated Leads, Solderable per JESD22-B102 (e3)
- Weight: 0.023 grams (Approximate)

IMPORTANT NOTICE

1. DIODES INCORPORATED (Diodes) AND ITS SUBSIDIARIES MAKE NO WARRANTY OF ANY KIND, EXPRESS OR IMPLIED, WITH REGARDS TO ANY INFORMATION CONTAINED IN THIS DOCUMENT, INCLUDING, BUT NOT LIMITED TO, THE IMPLIED WARRANTIES OF MERCHANTABILITY, FITNESS FOR A PARTICULAR PURPOSE OR NON-INFRINGEMENT OF THIRD PARTY INTELLECTUAL PROPERTY RIGHTS (AND THEIR EQUIVALENTS UNDER THE LAWS OF ANY JURISDICTION).
2. The Information contained herein is for informational purpose only and is provided only to illustrate the operation of Diodes' products described herein and application examples. Diodes does not assume any liability arising out of the application or use of this document or any product described herein. This document is intended for skilled and technically trained engineering customers and users who design with Diodes' products. Diodes' products may be used to facilitate safety-related applications; however, in all instances customers and users are responsible for (a) selecting the appropriate Diodes products for their applications, (b) evaluating the suitability of Diodes' products for their intended applications, (c) ensuring their applications, which incorporate Diodes' products, comply the applicable legal and regulatory requirements as well as safety and functional-safety related standards, and (d) ensuring they design with appropriate safeguards (including testing, validation, quality control techniques, redundancy, malfunction prevention, and appropriate treatment for aging degradation) to minimize the risks associated with their applications.
3. Diodes assumes no liability for any application-related information, support, assistance or feedback that may be provided by Diodes from time to time. Any customer or user of this document or products described herein will assume all risks and liabilities associated with such use, and will hold Diodes and all companies whose products are represented herein or on Diodes' websites, harmless against all damages and liabilities.
4. Products described herein may be covered by one or more United States, international or foreign patents and pending patent applications. Product names and markings noted herein may also be covered by one or more United States, international or foreign trademarks and trademark applications. Diodes does not convey any license under any of its intellectual property rights or the rights of any third parties (including third parties whose products and services may be described in this document or on Diodes' website) under this document.
5. Diodes' products are provided subject to Diodes' Standard Terms and Conditions of Sale (<https://www.diodes.com/about/company/terms-and-conditions/terms-and-conditions-of-sales/>) or other applicable terms. This document does not alter or expand the applicable warranties provided by Diodes. Diodes does not warrant or accept any liability whatsoever in respect of any products purchased through unauthorized sales channel.
6. Diodes' products and technology may not be used for or incorporated into any products or systems whose manufacture, use or sale is prohibited under any applicable laws and regulations. Should customers or users use Diodes' products in contravention of any applicable laws or regulations, or for any unintended or unauthorized application, customers and users will (a) be solely responsible for any damages, losses or penalties arising in connection therewith or as a result thereof, and (b) indemnify and hold Diodes and its representatives and agents harmless against any and all claims, damages, expenses, and attorney fees arising out of, directly or indirectly, any claim relating to any noncompliance with the applicable laws and regulations, as well as any unintended or unauthorized application.
7. While efforts have been made to ensure the information contained in this document is accurate, complete and current, it may contain technical inaccuracies, omissions and typographical errors. Diodes does not warrant that information contained in this document is error-free and Diodes is under no obligation to update or otherwise correct this information. Notwithstanding the foregoing, Diodes reserves the right to make modifications, enhancements, improvements, corrections or other changes without further notice to this document and any product described herein. This document is written in English but may be translated into multiple languages for reference. Only the English version of this document is the final and determinative format released by Diodes.
8. Any unauthorized copying, modification, distribution, transmission, display or other use of this document (or any portion hereof) is prohibited. Diodes assumes no responsibility for any losses incurred by the customers or users or any third parties arising from any such unauthorized use.
9. This Notice may be periodically updated with the most recent version available at <https://www.diodes.com/about/company/terms-and-conditions/important-notice>

The Diodes logo is a registered trademark of Diodes Incorporated in the United States and other countries.
All other trademarks are the property of their respective owners.
© 2023 Diodes Incorporated. All Rights Reserved.

www.diodes.com