

MAX40204

36V, Pin-Programmable Gain, Bidirectional CSA

General Description

The MAX40204 is a high-precision, bidirectional, high-side current-sense amplifier (CSA) with a wide input common-mode range from -0.1V (ground sensing) to 36V.

The device's ultra-low 2 μ V input offset voltage allows the use of small sense resistor to reduce power dissipation and a very low, 0.05% gain error ensures measurement accuracy.

The MAX40204 offers two gain options using a logic-level input (GAIN) that provides the flexibility to change the gain on the fly. On-the-fly gain adjustment capability allows the system to enhance accuracy when measuring current much smaller than set full-scale level. See [Table 1](#) for gain configurations. Additionally, the MAX40204 supports unidirectional and bidirectional current sensing with an external voltage applied to a reference input, REF.

The MAX40204 operates with single-supply in the range of 1.7V to 5.5V while consuming only 21 μ A. Low operating supply current and 70nA (typ) shutdown current help extend battery life and make the MAX40204 ideal for portable and battery-operated devices.

The MAX40204 is available in a small 8-bump, 0.35mm-pitch WLP (1.468mm x 0.848mm) and 8-pin TDFN (2mm x 2mm) packages and is specified over the -40°C to +125°C extended operating temperature range.

Applications

- Current Sensing in Power Management Systems
- Portable and Battery-Operated Systems
- Medical Instruments
- Base Station
- Smart Phones and Tablets
- Notebook Computers

Benefits and Features

- -0.1V to 36V Wide Input Common Mode
- Ultra-Low, 2 μ V Input Offset Voltage
- On-the-Fly Gain Setting Input
- Bidirectional/Unidirectional Current Sensing
- 20nA (max) Input Bias Current
- Extremely Low, 50nV/°C Input Offset Tempco
- 0.05% Gain Error
- 21 μ A Supply Current
- 70nA (typ) Shutdown Current
- 1.7V to 5.5V Single Supply Operating Range
- Space-Saving 8-Bump WLP and 8-Pin TDFN Packages

[Ordering Information](#) appears at end of data sheet.

Typical Application Diagram

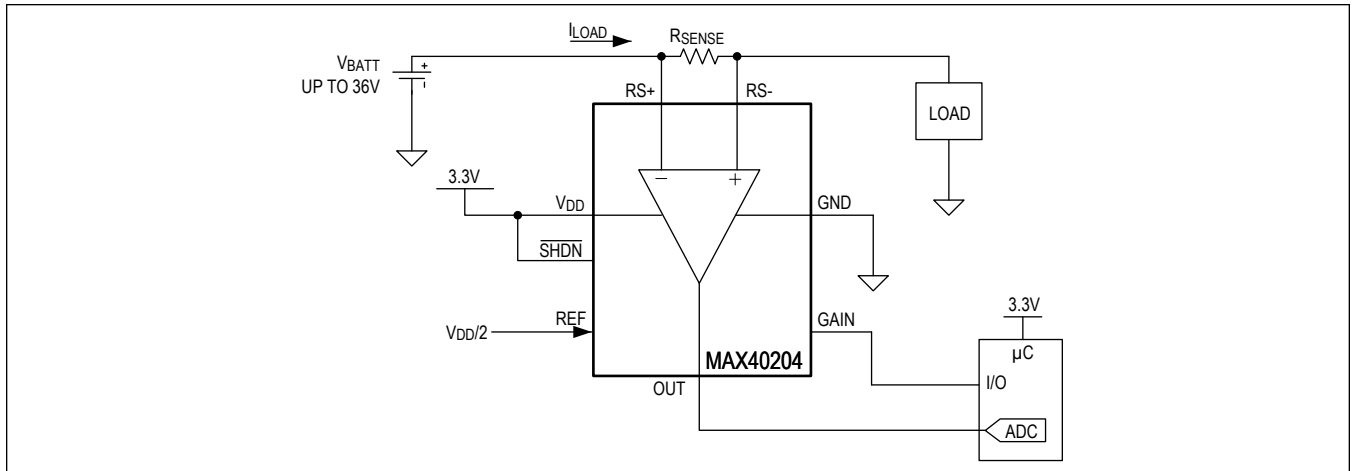

TABLE OF CONTENTS

General Description	1
Applications	1
Benefits and Features	1
Typical Application Diagram	2
Absolute Maximum Ratings	6
Package Information	7
TDFN-CU	7
8 WLP	8
Electrical Characteristics	10
Typical Operating Characteristics	12
Pin Configurations	15
8 TDFN	15
8 WLP	15
Pin Description	15
Detailed Description	17
Gain Selection Inputs, GAIN	17
Shutdown, SHDN	17
Low Offset Voltage and Low Gain Error	17
Reference Input, REF	17
Applications Information	19
Input Differential Signal Range	19
Choosing the Sense Resistor	19
Kelvin Connections	19
Efficiency and Power Dissipation	19
Input Filtering	19
Output Filtering	21
Bidirectional Application	21
Programmable Gain	22
Power-Supply Bypassing and Grounding	24
Ordering Information	24
Revision History	25

LIST OF FIGURES

Figure 1. Unidirectional Current-Sensing Operation	18
Figure 2. Bidirectional Current-Sensing Operation	18
Figure 3. Differential Input Filtering	20
Figure 4. Input Common-Mode Filtering	21
Figure 5. Filtering	21
Figure 6. Bidirectional Current-Sensing Application	22
Figure 7. Low Current Application	23
Figure 8. Input/Output Signal Representation	24

LIST OF TABLES

Table 1. Gain-Setting Connection	17
Table 2. V_{SENSE} Input Range.	19

Absolute Maximum Ratings

V _{DD} to GND.....	-0.3V to +6V	TDFN Package Continuous Power Dissipation (Multilayer Board)	
RS+ to RS-	±40V	(T _A = +70°C, derate 11.70mW/°C above +70°C)	936.90mW
RS+, RS- to GND	-0.3V to +40V	Operating Temperature Range	-40°C to +125°C
GAIN, REF, OUT, $\overline{\text{SHDN}}$ to GND	-0.3V to V _{DD} + 0.3V	Junction Temperature	+150°C
Continuous Input Current (any pin)	10mA	Storage Temperature Range	-40°C to +150°C
WLP Package Continuous Power Dissipation (Multilayer Board)		Soldering Temperature (reflow)	+260°C
(T _A = +70°C, derate 10.90mW/°C above +70°C).....	872mW		

Stresses beyond those listed under "Absolute Maximum Ratings" may cause permanent damage to the device. These are stress ratings only, and functional operation of the device at these or any other conditions beyond those indicated in the operational sections of the specifications is not implied. Exposure to absolute maximum rating conditions for extended periods may affect device reliability.

Package Information

TDFN-CU

Package Code	T822+3C
Outline Number	21-0168
Land Pattern Number	90-0065
Thermal Resistance, Single-Layer Board:	
Junction to Ambient (θ_{JA})	N/A
Junction to Case (θ_{JC})	N/A
Thermal Resistance, Four-Layer Board:	
Junction to Ambient (θ_{JA})	85.30°C/W
Junction to Case (θ_{JC})	8.9°C/W

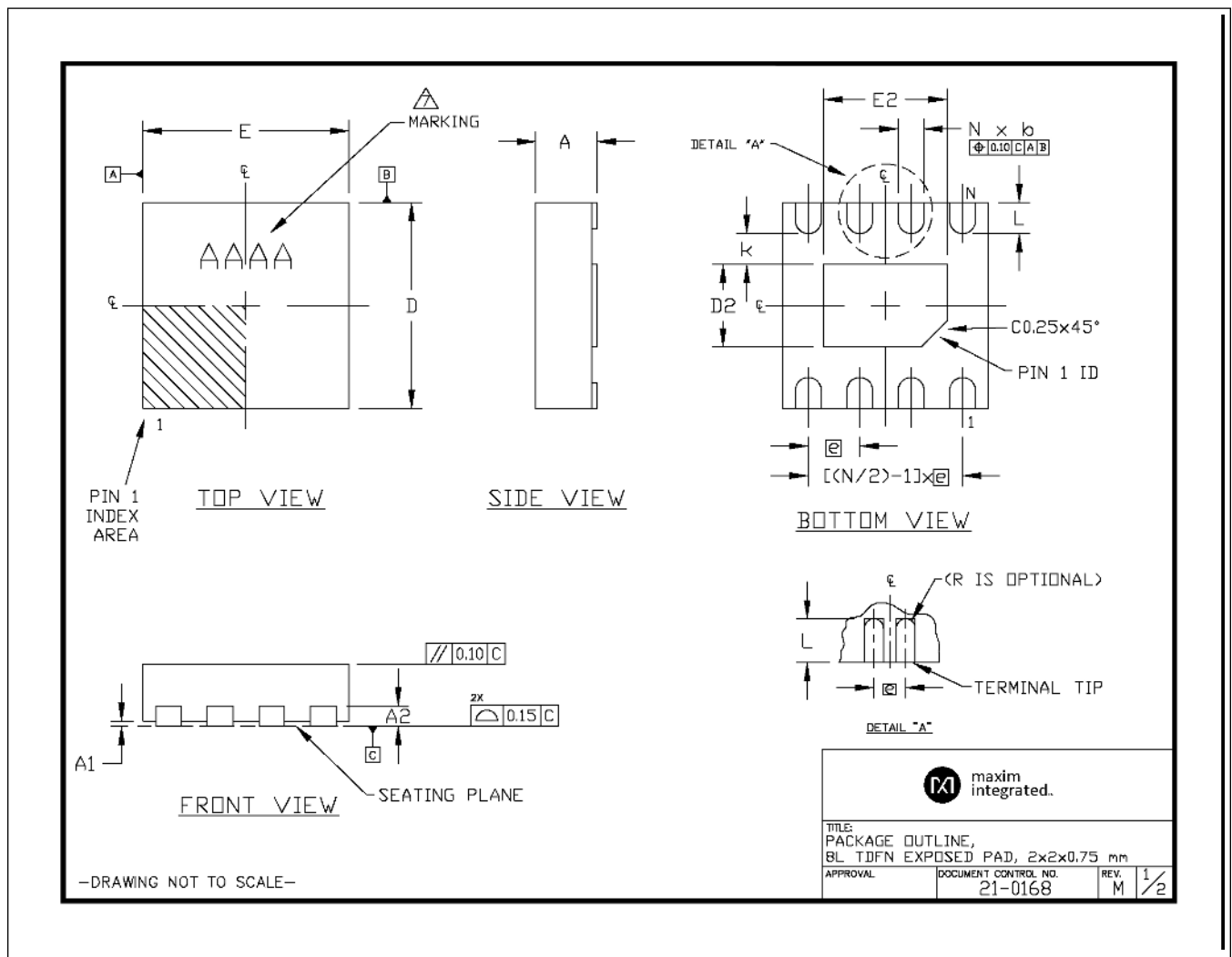

COMMON DIMENSIONS				PACKAGE VARIATIONS							
SYMBOL	MIN.	NOM.	MAX.	PKG. CODE	N	D2	E2	e	b	r	[(N/2)-1] x e
A	0.70	0.75	0.80	T822-1	8	0.70±0.10	1.30±0.10	0.50 TYP.	0.25±0.05	0.125	1.50 REF
D	1.90	2.00	2.10	T822-1C	8	0.70±0.10	1.30±0.10	0.50 TYP.	0.25±0.05	0.125	1.50 REF
E	1.90	2.00	2.10	T822-2	8	0.80±0.10	1.20±0.10	0.50 TYP.	0.25±0.05	0.125	1.50 REF
A1	0.00	--	0.05	T822-2C	8	0.80±0.10	1.20±0.10	0.50 TYP.	0.25±0.05	0.125	1.50 REF
L	0.20	0.30	0.40	T822-3	8	0.80±0.10	1.20±0.10	0.50 TYP.	0.25±0.05	0.125	1.50 REF
k	0.25 MIN.			T822-3C	8	0.80±0.10	1.20±0.10	0.50 TYP.	0.25±0.05	0.125	1.50 REF
A2	0.20 REF.			T822-5	8	0.80±0.10	1.20±0.10	0.50 TYP.	0.25±0.05	0.125	1.50 REF
				T822-5C	8	0.80±0.10	1.20±0.10	0.50 TYP.	0.25±0.05	0.125	1.50 REF

NOTES:

- ALL DIMENSIONS ARE IN mm. ANGLES IN DEGREES.
- WARPAGE SHALL NOT EXCEED 0.08mm.
- PACKAGE LENGTH/PACKAGE WIDTH ARE CONSIDERED AS SPECIAL CHARACTERISTIC(S).
- COMPLIES TO JEDEC MO229 EXCEPT D2 AND E2 DIMENSIONS.
- *N* IS THE TOTAL NUMBER OF LEADS.
- NUMBER OF LEADS SHOWN ARE FOR REFERENCE ONLY.
- MARKING IS FOR PACKAGE ORIENTATION REFERENCE ONLY.
- MATERIAL MUST BE COMPLIANT WITH MAXIM SPECIFICATION 10-0131 FOR SUBSTANCE CONTENT, MUST BE Eu ROHS COMPLIANT WITHOUT EXEMPTION AND Pb-FREE.
- ALL DIMENSIONS APPLY TO BOTH LEADED (-) AND PbFREE (+) PKG. CODES.



TITLE:
PACKAGE OUTLINE,
BL TJFN EXPOSED PAD, 2x2x0.75 mm

APPROVAL	DOCUMENT CONTROL NO. 21-0168	REV. M	2/2
----------	---------------------------------	-----------	-----

-DRAWING NOT TO SCALE-

8 WLP

Package Code	N80E1+1
Outline Number	21-100451
Land Pattern Number	Refer to Application Note 1891
Thermal Resistance, Single-Layer Board:	
Junction to Ambient (θ_{JA})	N/A
Junction to Case (θ_{JC})	N/A
Thermal Resistance, Four-Layer Board:	
Junction to Ambient (θ_{JA})	91.71°C/W
Junction to Case (θ_{JC})	N/A

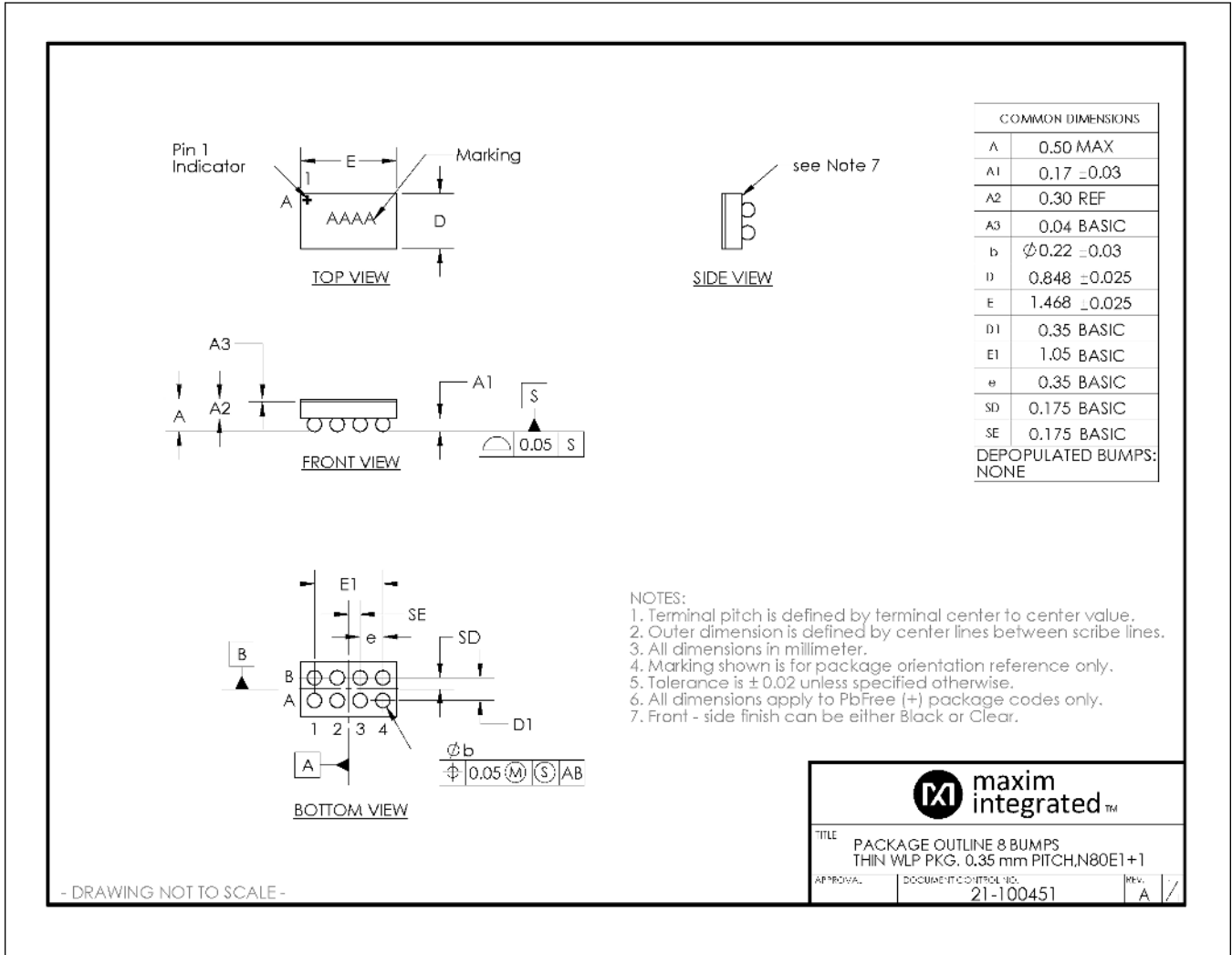

For the latest package outline information and land patterns (footprints), go to www.maximintegrated.com/packages. Note that a "+", "#", or "-" in the package code indicates RoHS status only. Package drawings may show a different suffix character, but the drawing pertains to the package regardless of RoHS status.

Package thermal resistances were obtained using the method described in JEDEC specification JESD51-7, using a four-layer board. For detailed information on package thermal considerations, refer to www.maximintegrated.com/thermal-tutorial.

Electrical Characteristics

($V_{DD} = V_{SHDN} = 1.8V$, $V_{RS+} = V_{RS-} = +12V$, $V_{SENSE} = (V_{RS+} - V_{RS-}) = 50mV$, $G = 10V/V$, $V_{REF} = 0.9V$, $R_L = 10k\Omega$ to GND, $T_A = -40^\circ C$ to $+125^\circ C$, unless otherwise noted. Typical values are at $+25^\circ C$.)

PARAMETER	SYMBOL	CONDITIONS		MIN	TYP	MAX	UNITS
POWER SUPPLY							
Supply Voltage Range	V_{DD}	Guaranteed by PSRR		1.7		5.5	V
Shutdown Supply Current	I_{SHDN}	$-40^\circ C \leq T_A \leq +85^\circ C$			70	300	nA
		$-40^\circ C \leq T_A \leq +125^\circ C$			70	800	
Supply Current	I_{DD}	No load	$T_A = +25^\circ C$		21	31	μA
			$-40^\circ C \leq T_A \leq +125^\circ C$		21	41	μA
Power-Supply Rejection Ratio	PSRR	$G = 10V/V$		100	110		dB
		$G = 100V/V$		100	110		
Turn-On Time	t_{EN}	Turn-on from shutdown, measured at 90% of nominal final value			400		μs
Power-On Time	t_{ON}	$V_{DD} = 0$ to 1.8V, measured at 90% of nominal final value			400		μs
DC CHARACTERISTICS							
Input Common-Mode Range	V_{CM}	Guaranteed by CMRR		-0.1		36	V
Common-Mode Rejection Ratio	CMRR	$G = 10V/V$		110	140		dB
		$G = 100V/V$		110	140		
Input Bias Current	I_B	$V_{SENSE} = (V_{RS+} - V_{RS-}) = 0V$			1	20	nA
Input Offset Current	I_{OS}	$V_{SENSE} = (V_{RS+} - V_{RS-}) = 0V$			0.1	2	nA
Input Offset Voltage	V_{OS}	$GAIN = 10V/V$	$T_A = +25^\circ C$		2	20	μV
			$-40^\circ C \leq T_A \leq +125^\circ C$		2	35	
		$GAIN = 100V/V$	$T_A = +25^\circ C$		2	15	
			$-40^\circ C \leq T_A \leq +125^\circ C$		2	30	
Input Offset Drift	TCV_{OS}				50		nV/ $^\circ C$
Gain	G	(Note 1)	$V_{GAIN} = \text{low}$		10		V/V
			$V_{GAIN} = \text{high}$		100		V/V
Gain Selection Settling Time		V_{OUT} to settle within $\pm 100mV$			0.2		ms
Gain Error	GE	$G = 10V/V$	$T_A = +25^\circ C$		0.05	0.15	%
			$-40^\circ C \leq T_A \leq +125^\circ C$		0.05	0.30	
		$G = 100V/V$	$T_A = +25^\circ C$		0.05	0.15	
			$-40^\circ C \leq T_A \leq +125^\circ C$		0.05	0.30	
Output-Voltage High	V_{OH}	$V_{OH} = V_{DD} - V_{OUT}$, $I_{SOURCE} = 100\mu A$				20	mV
Output-Voltage Low	V_{OL}	$I_{SINK} = 100\mu A$				20	mV
Output Impedance	Z_{OUT}				200		m Ω

Electrical Characteristics (continued)

($V_{DD} = V_{SHDN} = 1.8V$, $V_{RS+} = V_{RS-} = +12V$, $V_{SENSE} = (V_{RS+} - V_{RS-}) = 50mV$, $G = 10V/V$, $V_{REF} = 0.9V$, $R_L = 10k\Omega$ to GND, $T_A = -40^\circ C$ to $+125^\circ C$, unless otherwise noted. Typical values are at $+25^\circ C$.)

PARAMETER	SYMBOL	CONDITIONS	MIN	TYP	MAX	UNITS
AC CHARACTERISTICS						
Small-Signal Bandwidth	BW _{3dB}	G = 10V/V		15		kHz
		G = 100V/V		1.8		
Input-Voltage Noise Density	V _N	f = 100Hz		150		nV/ \sqrt{Hz}
AC Common-Mode Rejection Ratio	CMRR _{AC}	f = 10kHz, 300mV _{p-p} sinusoidal waveform		80		dB
Settling Time	t _S	V _{OUT} from 400mV to 1.4V, G = 10V/V and G = 100V/V, within 12-bit accuracy		1,500		μs
Capacitive Load		No isolation resistor		500		pF
INPUT REFERENCE						
Input Reference Voltage Range	V _{REF}		0		$V_{DD}/2 + 0.1$	V
DIGITAL INPUTS DC CHARACTERISTICS (SHDN AND GAIN)						
Input High Voltage	V _{IH}		1.3			V
Input Low Voltage	V _{IL}				0.55	V

Note 1: Maximum sense voltage for G = 10V/V: 150mV with $V_{DD} > 3V$; 100mV with $V_{DD} = 1.8V$.

Typical Operating Characteristics

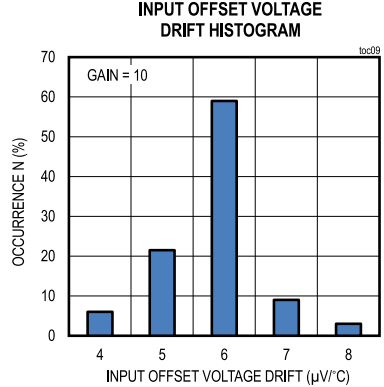
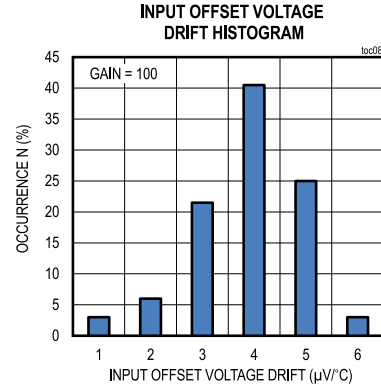
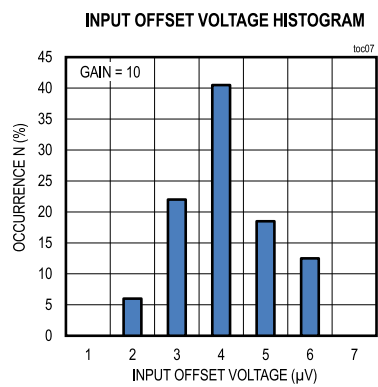
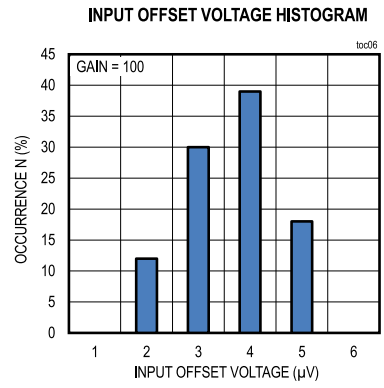
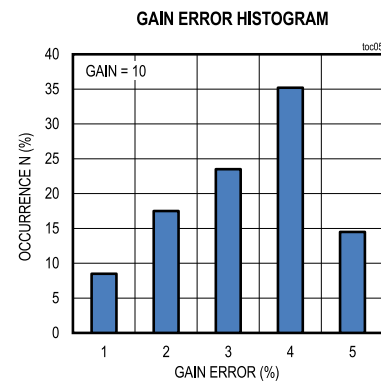
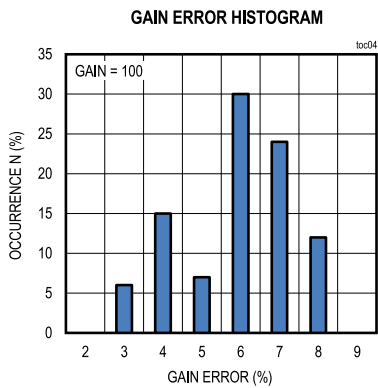
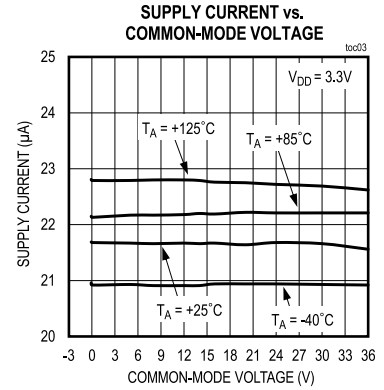
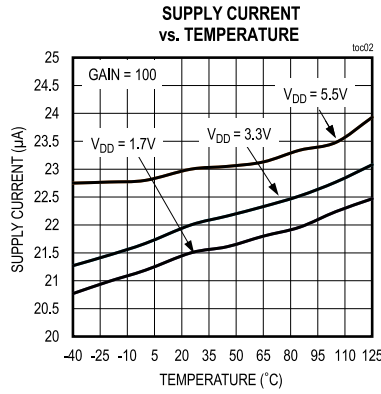
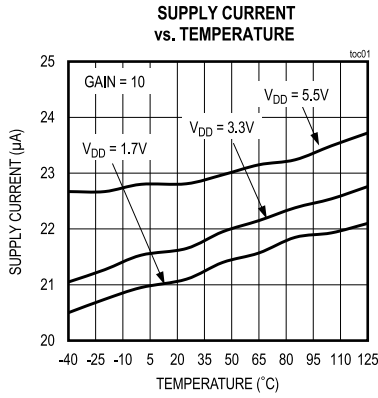

Typical Operating Characteristics (continued)

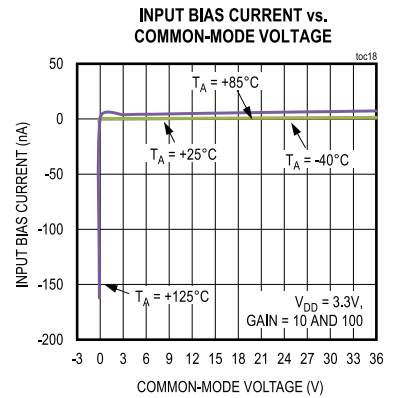
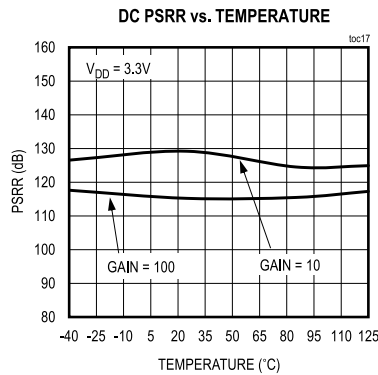
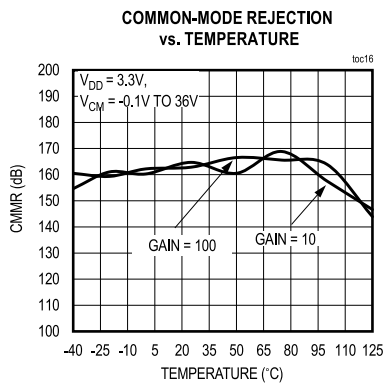
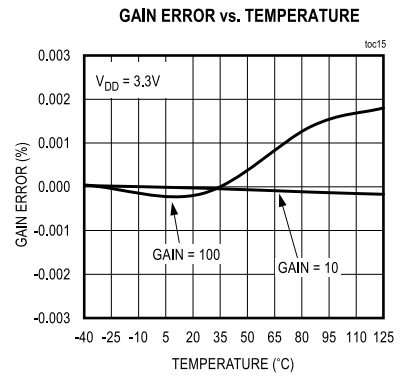
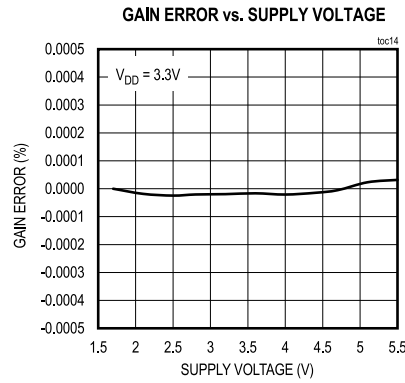
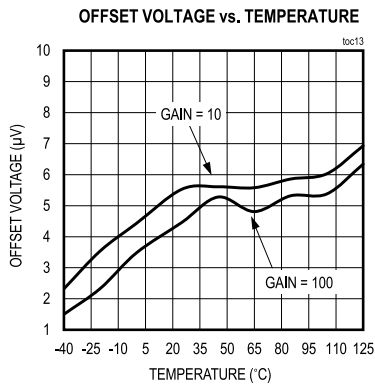
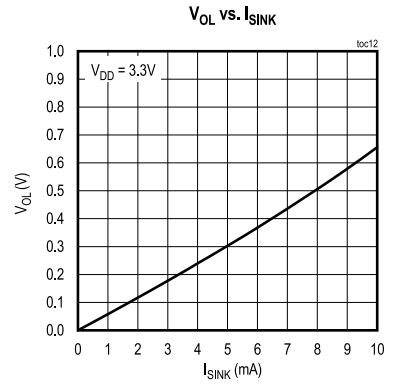
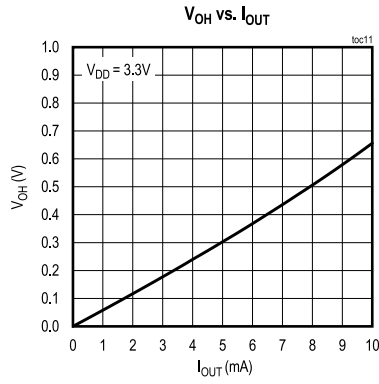
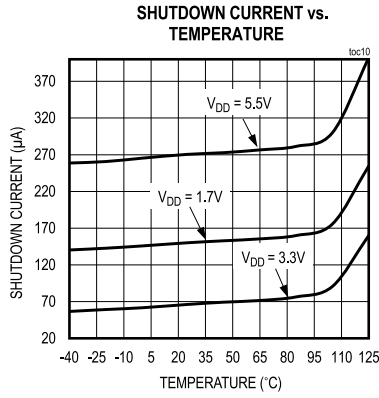

Typical Operating Characteristics (continued)

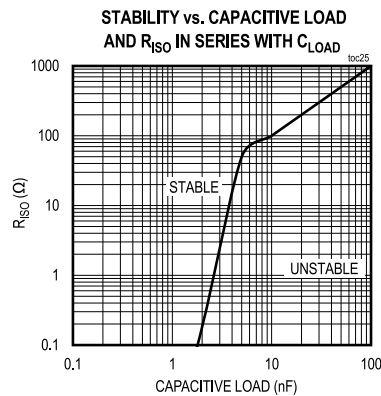
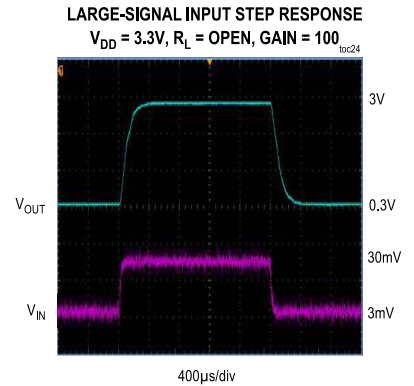
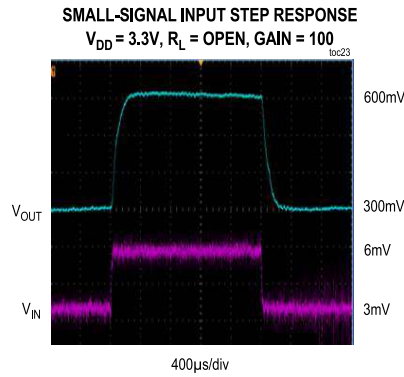
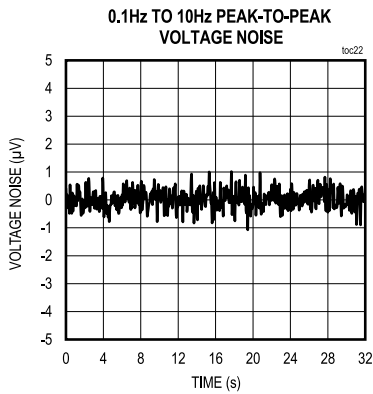
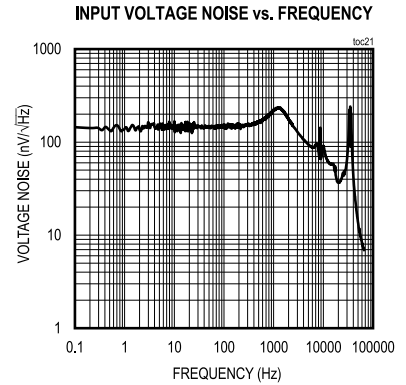
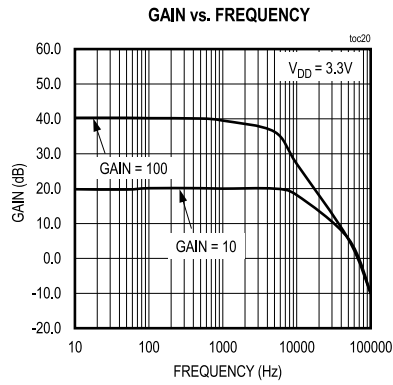
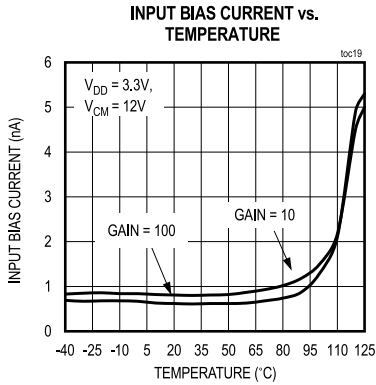

Pin Configurations

8 TDFN

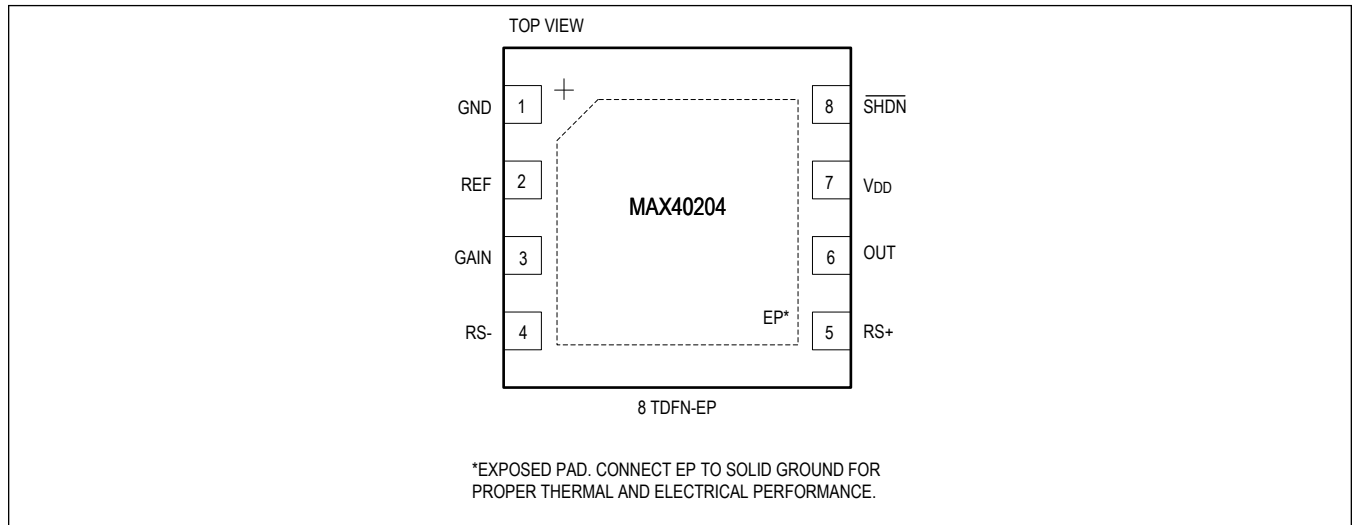

8 WLP

TOP VIEW (BUMP SIDE DOWN)

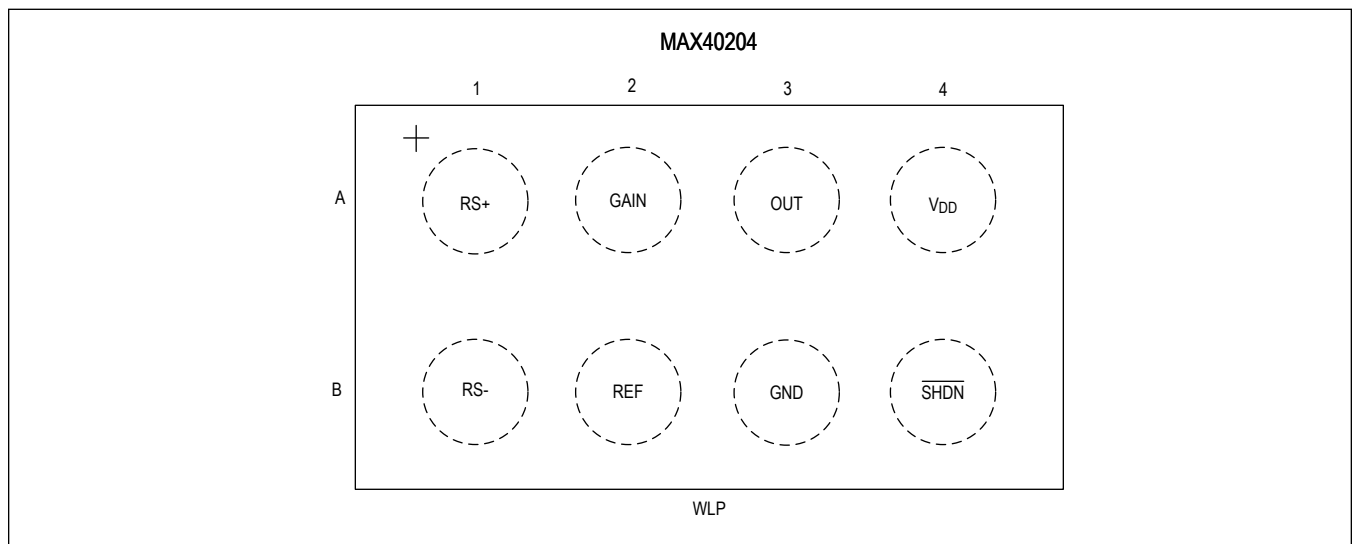

Pin Description

PIN		NAME	FUNCTION
8 TDFN	8 WLP		
1	B3	GND	Ground

Pin Description (continued)

PIN		NAME	FUNCTION
8 TDFN	8 WLP		
2	B2	REF	Reference Input. Connect REF to an external voltage from 0V to $V_{DD}/2$ to set the output voltage level of the CSA corresponding to no-measured current. Connect REF to 0V to configure the MAX40204 for unidirectional current sensing. Connect REF to $V_{DD}/2$ to configure the MAX40204 for bidirectional current-sensing measured current.
3	A2	GAIN	Gain Selection Input. Connect GAIN to V_{DD} to set the gain of the CSA to 100V/V. Connect GAIN to GND to set the gain of the CSA to 10V/V.
4	B1	RS-	Negative Current-Sensing Input. Connect a sense resistor between RS- and RS+. See the Choosing the Sense Resistor section for more detail.
5	A1	RS+	Positive Current-Sensing Input. Connect a sense resistor between RS+ and RS-. See the Choosing the Sense Resistor section for more detail.
6	A3	OUT	Current-Sense Amplifier Output. V_{OUT} is proportional to the sense voltage across the sense resistor connected between RS+ and RS-.
7	A4	V_{DD}	Positive Supply Voltage Input. Bypass V_{DD} to GND with 0.1 μ F and 4.7 μ F capacitors in parallel as close as possible to the supply voltage input.
8	B4	$\overline{\text{SHDN}}$	Active-Low Shutdown Input. Connect $\overline{\text{SHDN}}$ to GND to place the device in shutdown mode. Connect SHDN to V_{DD} for normal operation.
EP	—	EP	Exposed Pad. Connect to a large-area contiguous ground plane for improved power dissipation. Do not use as the only ground connection for the part.

Detailed Description

The MAX40204 is a single-supply, high-accuracy CSA that operates with a wide common-mode input range of -0.1V to 36V independent of the supply voltage (V_{DD}). An external sense resistor connected between RS+ and RS- measures the load current and generates an output signal proportional to the set gain. See [\[\[Gain Setting Connection\]\]](#) for gain-setting configuration. The MAX40204 offers both unidirectional and bidirectional current-sensing schemes using a reference input (REF). See the [Reference Input](#) section for more detail. Low quiescent current of 21 μ A and 70nA shutdown current extend battery life and make the MAX40204 ideal for many battery-powered applications.

The MAX40204's low input offset voltage, tight gain error, and low temperature drift characteristics allow the use of small sense resistors in systems that require high efficiency and accuracy. These features allow monitoring of power-supply load current even if the rail is shorted to ground. High-side current sensing does not interfere with the ground path of the load being measured, making the MAX40204 particularly useful in a wide range of high-reliability systems. In addition, the extended common-mode input range below ground makes the MAX40204 suitable for low-side current sensing.

Gain Selection Inputs, GAIN

Unlike the available CSAs on the market that offer fixed-gain options, the MAX40204 features an input, GAIN, that provides the flexibility to change the gain on the fly based on its input logic. See [Table 1](#) for more detail. This on-the-fly gain setting capability not only enhances accuracy measurement at the low end of the full-scale input range, but also allows the MAX40204 to be used in multiple applications with different current ranges. For example, a 150m Ω sense resistor used for 1A load applications produces a 150mV full-scale sense voltage between the inputs and 1.5V at the output with a gain of 10V/V. The same sense resistor could be used for 1/10th of load current and provide 1.5V output voltage with a gain of 100V/V. Since the input offset voltage is 2 μ V, its impact on the accuracy is insignificant for both gain options. Furthermore, the ADC can process both cases with the same resolution.

Table 1. Gain-Setting Connection

GAIN	GAIN (V/V)
GND	10
V_{DD}	100

Shutdown, $\overline{\text{SHDN}}$

Shutdown input is an active-low logic input ($\overline{\text{SHDN}}$) that places the device in the shutdown mode of operation. In shutdown mode, the device enters a very low power mode and consumes only 70nA (typ) of supply current. Drive $\overline{\text{SHDN}}$ high for normal operation. Drive $\overline{\text{SHDN}}$ low to place the device in shutdown mode.

Low Offset Voltage and Low Gain Error

The MAX40204 utilizes capacitive-coupled chopper instrumentation amplifier (CCIA) architecture to achieve a low-input offset voltage of 2 μ V (typ). These techniques also enable extremely low-input offset voltage drift over time and temperature to

50nV/ $^{\circ}$ C.

The precision V_{OS} specification allows accurate current measurements with lower values of current-sense resistors, thus reducing power dissipation in battery-powered systems, as well as load-regulation issues in low-voltage DC power supplies.

Working with error tolerances with very few internal blocks in this architecture is instrumental in achieving a gain error of less than 0.30% over the entire temperature range of -40 $^{\circ}$ C to +125 $^{\circ}$ C.

Reference Input, REF

The MAX40204 supports both unidirectional and bidirectional current-sensing operations. Connecting the reference input (REF) to ground configures the MAX40204 for unidirectional current sensing. For unidirectional current sensing, the output is referenced to ground and the output voltage V_{OUT} is proportional to the positive voltage drop (V_{SENSE}) from

RS+ to RS-. (See Figure 1 for unidirectional operation.) The MAX40204 operates as a bidirectional CSA by application of a low source impedance reference voltage to REF above ground, typically $V_{DD}/2$. In the bidirectional current-sensing mode of operation, the output voltage V_{OUT} is referenced to V_{REF} . See Figure 2 for bidirectional operation.

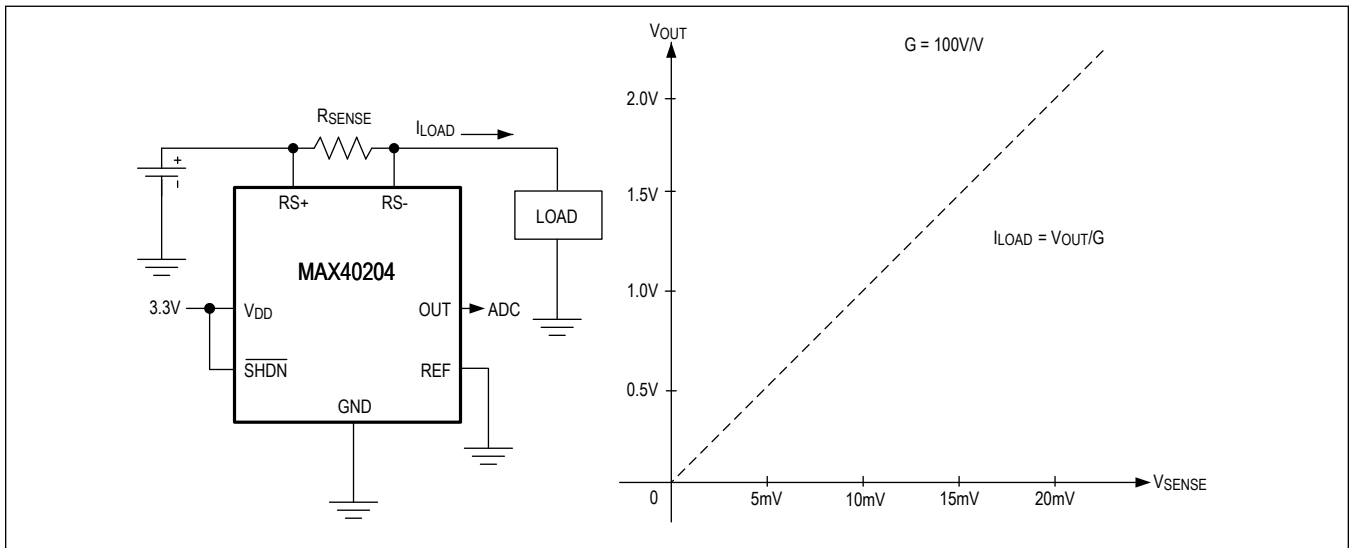

Figure 1. Unidirectional Current-Sensing Operation

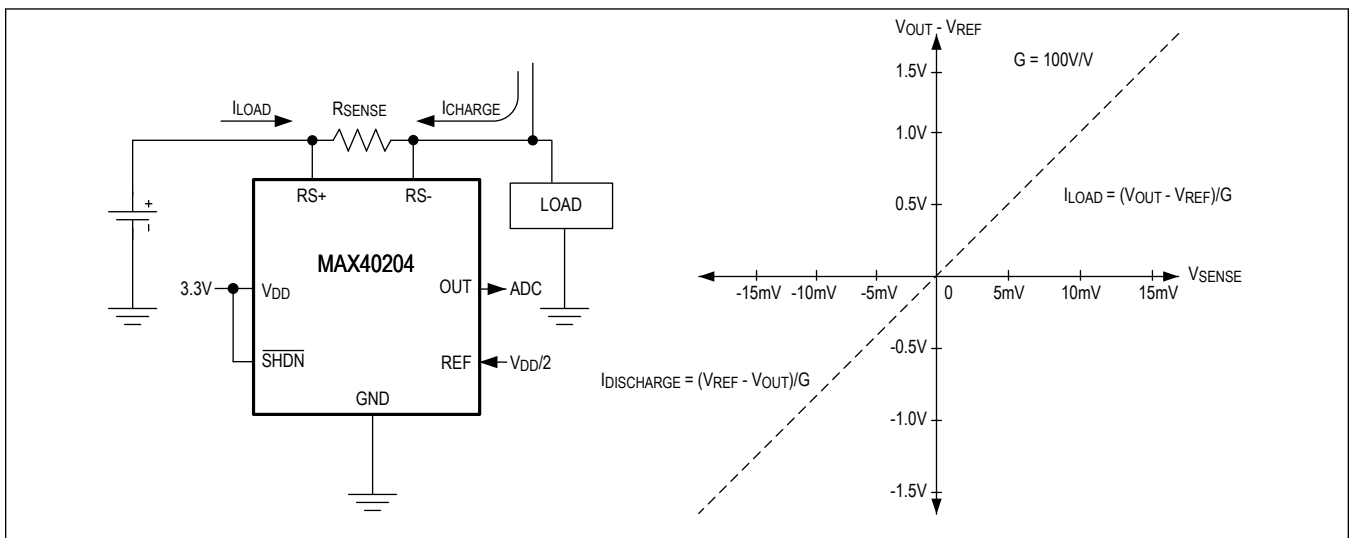

Figure 2. Bidirectional Current-Sensing Operation

Applications Information

Input Differential Signal Range

The MAX40204's input structure is optimized for sensing small differential signals as low as 17mV full scale (V_{FS}) for high efficiency with lowest power dissipation in the sense resistor, or 150mV full scale for high dynamic range. The input differential signal range is determined by the following equation:

$$V_{(SENSE\ RANGE)} = \frac{V_{DD}}{GAIN}$$

The input differential voltage range is estimated for V_{DD} from 1.7V to 5.5V using a gain of 100V/V and 10V/V. For a gain of 10V/V, the max V_{SENSE} is 150mV when $V_{DD} > 3V$ and 100mV when $V_{DD} = 1.7V$. (See [Table 2](#).)

Ideally, the maximum load current develops the full-scale sense voltage across the current-sense resistor. Choose the gain needed to yield the maximum output voltage required for the application:

$$V_{OUT} = GAIN \times V_{SENSE}$$

Table 2. V_{SENSE} Input Range

GAIN (V/V)	V_{SENSE} RANGE (mV) WITH V_{DD} (1.7V)	V_{SENSE} RANGE (mV) WITH V_{DD} (5.5V)
10	100	150
100	17	55

Choosing the Sense Resistor

Voltage Loss

A high R_{SENSE} value causes the power-source voltage to drop due to IR loss. For minimal voltage loss, use the lowest R_{SENSE} value.

Accuracy

Use the following linear equation to calculate total error:

$$V_{OUT} = (GAIN \pm GE) \times V_{SENSE} \pm (GAIN \times V_{OS})$$

A high R_{SENSE} value allows lower currents to be measured more accurately because offsets are less significant when the sense voltage is larger. Note that the tolerance and temperature coefficient of the chosen resistors directly affect the precision of any measurement system. For best performance, select R_{SENSE} to provide approximately maximum input differential sense voltage.

Kelvin Connections

Because of the high currents that may flow through R_{SENSE} based on the application, be sure to eliminate solder and parasitic trace resistance from causing errors in the sense voltage. Either use a four-terminal current sense resistor or use Kelvin (force and sense) PCB layout techniques.

Efficiency and Power Dissipation

At high current levels, the I^2R losses in R_{SENSE} can be significant. This should be taken into consideration when choosing the resistor value and its power dissipation (wattage) rating. The sense resistor's value will drift if it is allowed to heat up excessively. The precision V_{OS} of the MAX40204 allows the use of small sense resistors to reduce power dissipation and reduce hot spots.

Input Filtering

Some applications of CSAs need to measure currents accurately even in the presence of both differential and common-mode ripple, as well as a wide variety of input transient conditions. The MAX40204 allows two methods of filtering to help improve performance in the presence of input common-mode voltage and input differential voltage transients. [Figure 3](#)

shows a differential input filter. The capacitor C_{IN} across $RS+$ and $RS-$ along with the resistor R_{IN} helps filter against input differential voltages and prevents them from reaching the MAX40204. The corner frequency of this filter is determined by the choice of R_{IN} , C_{IN} . Figure 4 shows a common-mode input filter. The choice of capacitance depends on corner frequency after R_{IN} is chosen. In case of mismatch or error in application design, an additional DC error is accumulated as offset voltage and increased gain error. $V_{OS} = (R_{IN} \times I_{OFFSET}) + (DR_{IN} \times I_{BIAS})$ DR_{IN} is the resistance mismatch in R_{IN} at $RS+$ and $RS-$. If DR_{IN} is too small, its effect can be neglected. Since I_{OFFSET} of the MAX40204 is smaller than $2nA$, and if we want to make sure V_{OS} is less than a $1\mu V$ range, choosing: $R_{IN} < (V_{OS} \div I_{OFFSET})$ For gain error, it depends on its input impedance and R_{IN} .

$$GE = \frac{-R_{IN}}{2 \times Z_{IN}}$$

Avoid additional gain error shift due to the effect of R_{IN} . For gain error, the MAX40204 is 0.15%. If the margin of additional effect of R_{IN} results in a gain error shift of less than 0.02%, then:

$$R_{IN} < \frac{0.02\%}{2 \times Z_{IN}} = 60\Omega$$

So R_{IN} can be chosen $\leq 50\Omega$.

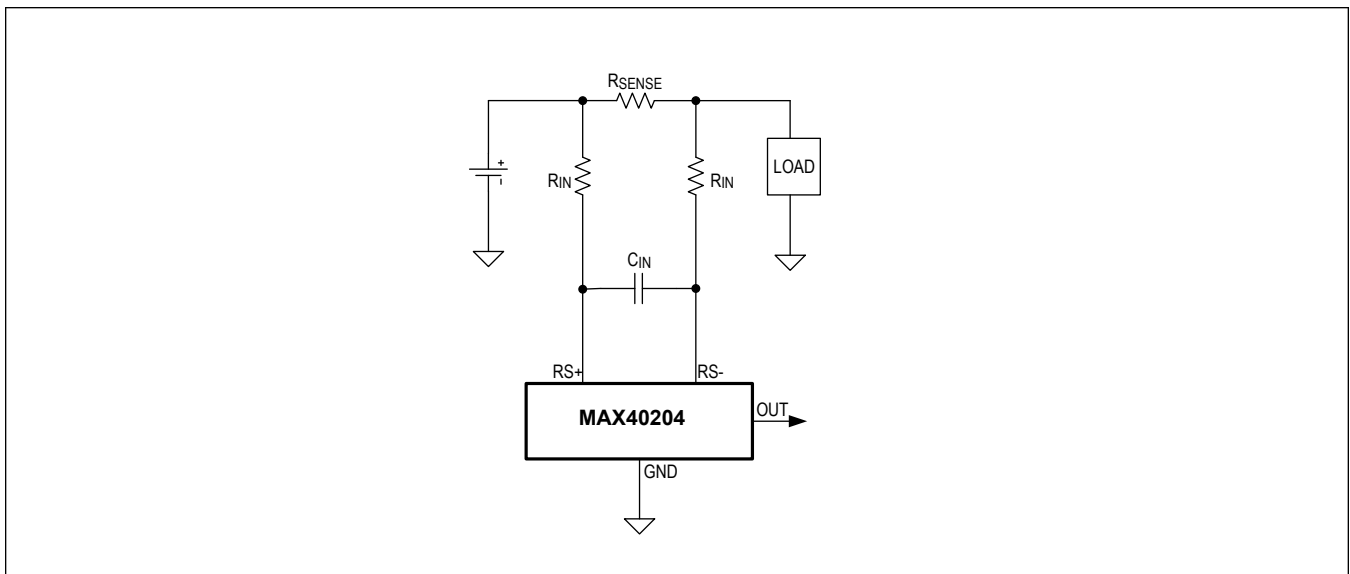

Figure 3. Differential Input Filtering

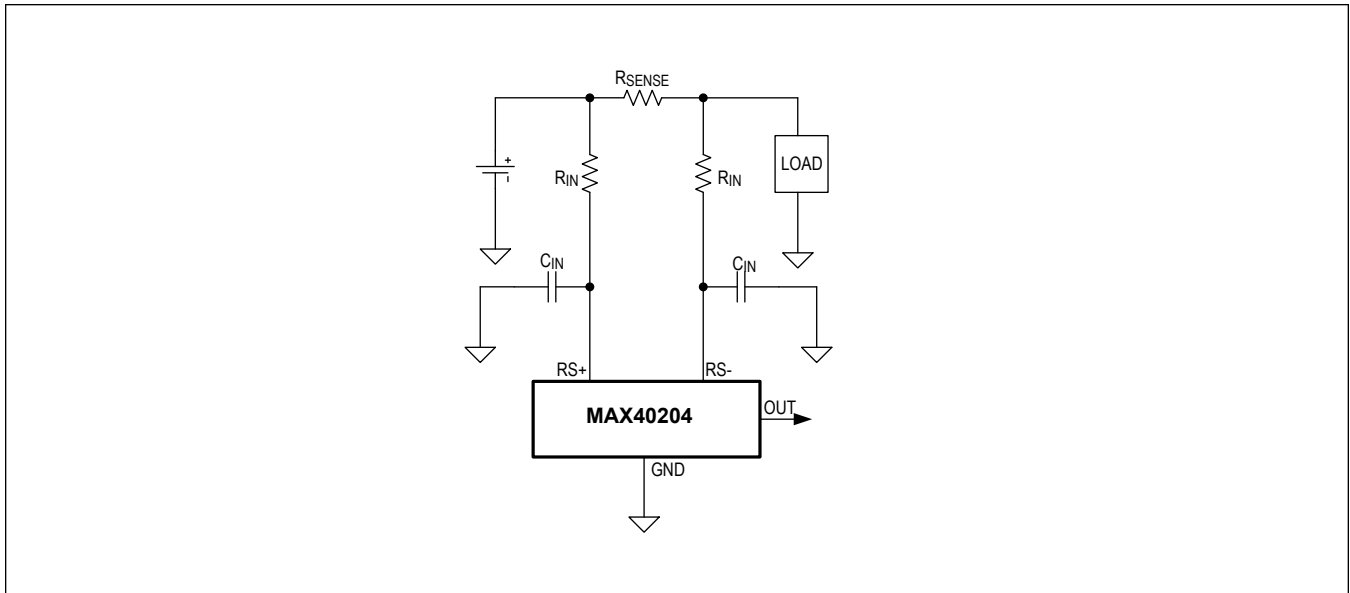

Figure 4. Input Common-Mode Filtering

Output Filtering

The internal architecture of the MAX40204 suppresses the DC offset, 1/f noise, and accumulates at higher frequencies so that they can be filtered out. Hence, minute AC disturbances can be observed at 10kHz and 20kHz. It is recommended to add an output filter after the MAX40204 to avoid noise and unwanted frequency disturbances at the output with 4kHz -3dB fc (see [Figure 5](#)). (Suggested values of C and R: 22nF and 1.8kΩ, respectively.)

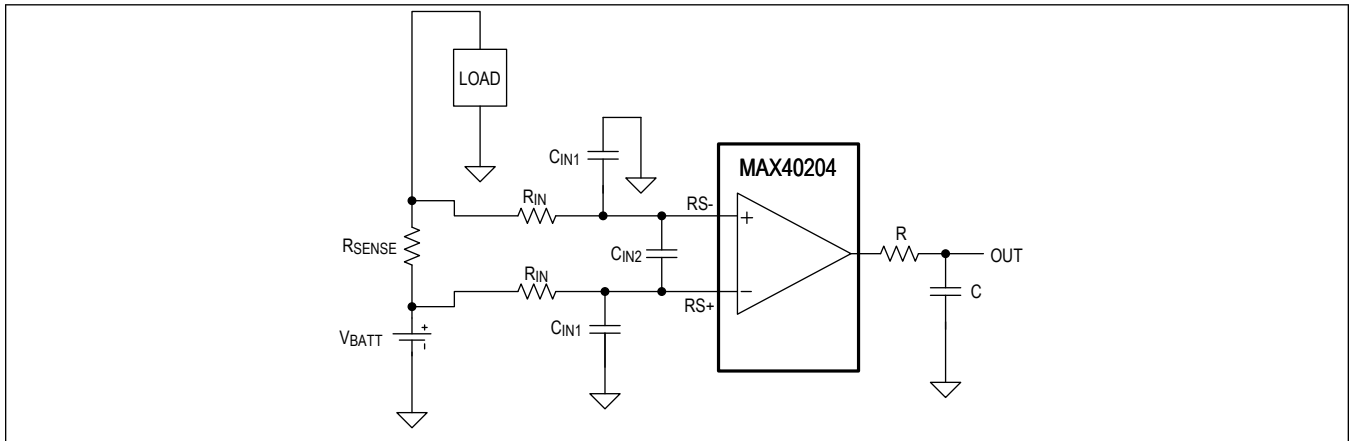

Figure 5. Filtering

Bidirectional Application

Battery-powered systems may require a precise bidirectional CSA to accurately monitor the battery’s charge and discharge currents. Measurements of the two separate outputs with respect to GND yield an accurate measure of the charge and discharge currents, respectively ([Figure 6](#)).

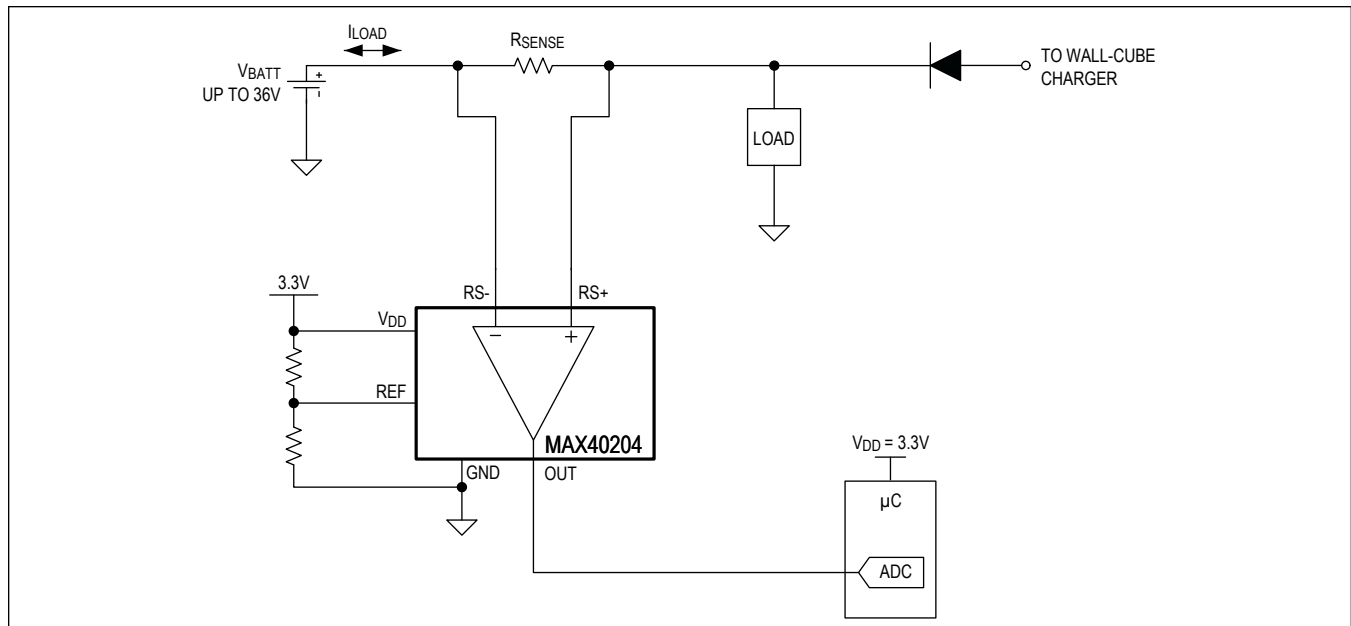

Figure 6. Bidirectional Current-Sensing Application

Programmable Gain

The MAX40204 features a logic-level gain input (GAIN) that allows the system to switch between two gain settings—10V/V and 100V/V—during normal operation. (See the [Gain Selection Inputs](#) section for more detail.) Combined with the MAX40204's ultra-low input offset voltage, the on-the-fly programmable-gain capability offers the advantage of adjusting the gain for optimum performance during normal operation, a desirable feature not available in fixed-gain CSAs. [Figure 7](#) shows a typical application with low current range using the MAX40204. Typically, for a three-decade load range, a 12-bit ADC would be required to ensure the process of true dynamic range of the measuring signal and also allow some margin for other sources of error in the system. But in [Figure 7](#), the system is using a 10-bit ADC because the MAX40204 programmable-gain input allows the system to pump up the input signal in the higher portion of the ADC's dynamic range, thus increasing immunity of the signal to noise and system errors.

In [Figure 7](#), the MAX40204 uses a 5Ω resistor to sense the load current, and its output feeds into a 10-bit, ~1.75mV LSB ADC. At a minimum load current of 30μA, the sense resistor generates 150μV across the sense resistor. Taking into account ±10μV(max) input offset voltage, the sensed voltage can vary from 140μV to 160μV, which is only ±6.6% of the measured signal. For this level of current, a gain configuration of 10V/V ($V_{GAIN} = GND$), is not enough for the ADC to process the input signal. The best gain configuration would be 100V/V ($V_{GAIN} = V_{DD}$) to boost signal and accurately measure the input signal

At a maximum load current of 30mA, the impact of the input offset voltage on the measured signal is even more insignificant: ±0.66%. In this case, however, the 100V/V gain configuration would not be practical due to the output dynamic range limitations dictated by the operating supply voltage of the MAX40204. An accurate signal representation is achieved by using a 10V/V gain configuration, resulting in an output variation range of 1.4895V to 1.5105V. See [Figure 8](#) for more detail.

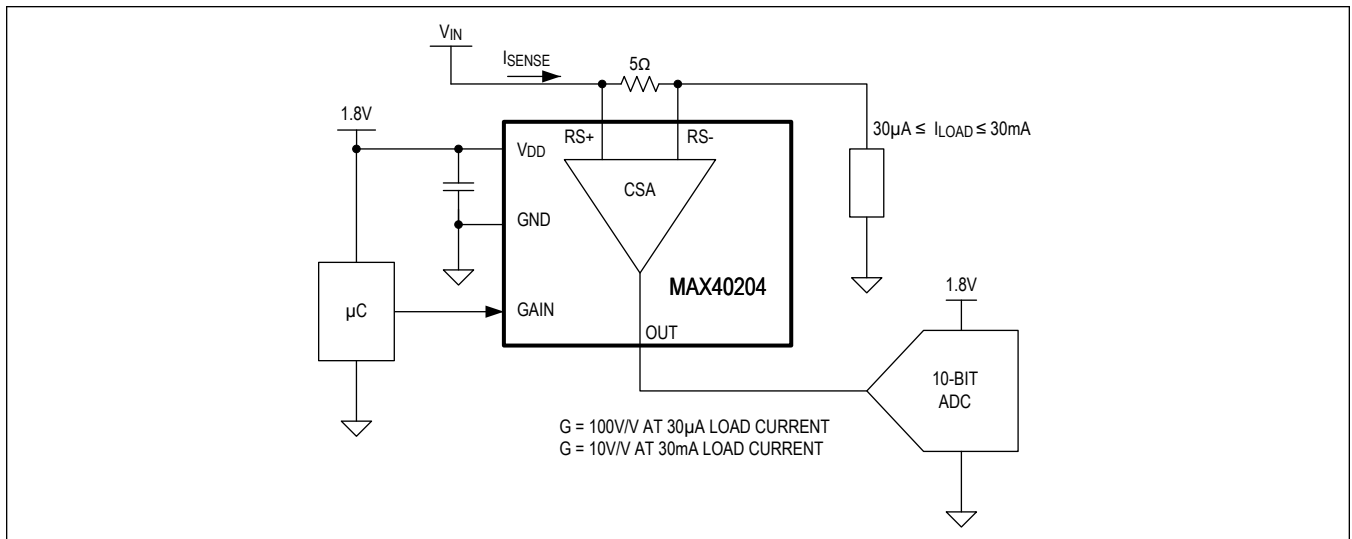

Figure 7. Low Current Application

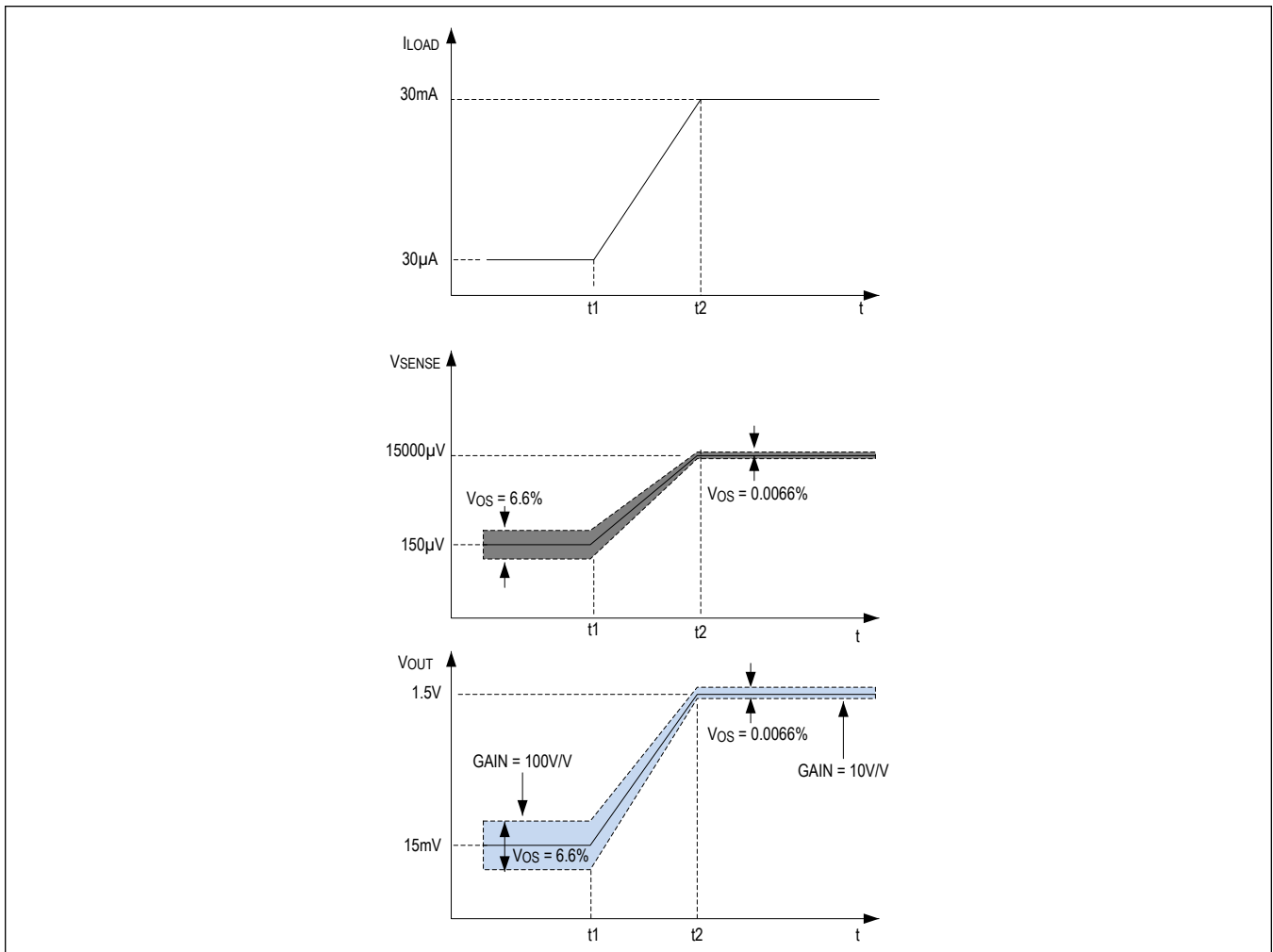

Figure 8. Input/Output Signal Representation

Power-Supply Bypassing and Grounding

Bypass the MAX40204's V_{DD} to ground with a 0.1µF capacitor. Grounding these devices requires no special precautions—follow the same cautionary steps that apply to the rest of the system. High-current systems can experience large voltage drops across a ground plane, and this drop may add to or subtract from V_{OUT} . Using a differential measurement between OUT and REF prevents this problem. For highest current-measurement accuracy, use a single-point star ground. Connect the exposed pad to a solid ground to ensure optimal thermal performance.

Ordering Information

PART NUMBER	TEMP RANGE	PIN-PACKAGE
MAX40204ANA+T	-40°C to +125°C	8-Bump WLP
MAX40204ATA+T*	-40°C to +125°C	8-Pin TDFN-CU

+Denotes a lead(Pb)-free/RoHS-compliant package.

T = Tape and reel.

*Future product—contact factory for availability.

Revision History

REVISION NUMBER	REVISION DATE	DESCRIPTION	PAGES CHANGED
0	9/20	Release for intro	—
1	10/20	Updated <i>Electrical Characteristics</i>	10, 11

For pricing, delivery, and ordering information, please visit Maxim Integrated's online storefront at <https://www.maximintegrated.com/en/storefront/storefront.html>.

Maxim Integrated cannot assume responsibility for use of any circuitry other than circuitry entirely embodied in a Maxim Integrated product. No circuit patent licenses are implied. Maxim Integrated reserves the right to change the circuitry and specifications without notice at any time. The parametric values (min and max limits) shown in the Electrical Characteristics table are guaranteed. Other parametric values quoted in this data sheet are provided for guidance.