

REVISIONS					
REV	ECO	DESCRIPTION	DATE	BY	APPR
B1	-	RELEASED DRAWING	Nov-20-2014	Ben	Tommy
B2	-	VOLTAGE UPDATE AND ADD KEY ICON	Dec-18-2020	Ronald	Tommy

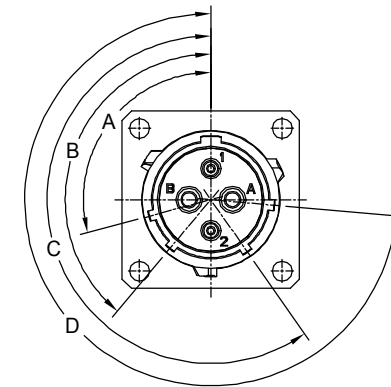
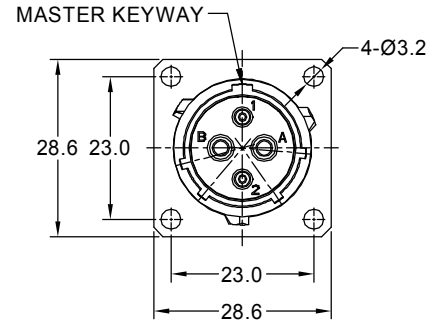
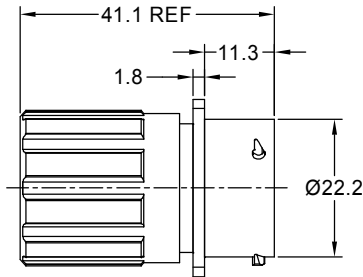

NOTES : (UNLESS OTHERWISE SPECIFIED)

1. MATERIAL :

- SHELL : ZINC ALLOY , NICKEL PLATED.
- INSERT : THERMOPLASTIC , UL94 V-0.
- END CAP : THERMOPLASTIC , UL94 V-0.
- PLASTIC BUSHING : THERMOPLASTIC , UL94 V-0.
- SEAL GASKET : NBR/SILICONE RUBBER.
- O-RING : NBR/SILICONE RUBBER.
- WIRE SEAL : SILICONE RUBBER.

2. SPECIFICATIONS :

- 2.1 RATED CURRENT :
  - 2.1.1 16# CONTACT 13A (MAX).
  - 2.1.1 2.5mm CONTACT 23A (MAX).
- 2.2 RATED VOLTAGE : 500V ( AC/DC ) .
- 2.3 OPERATING TEMPERATURE : SEE CHART.
- 2.4 DIELECTRIC WITHSTANDING VOLTAGE : LESS THAN 2 MILLIAMPS CURRENT LEAKAGE@2000 VOLTS AC.
- 2.5 INSULATION RESISTANCE : 5000 MEGOHMS MIN.
- 2.6 IP--CLASS : IP67 (MATED CONDITION).
- 2.7 MATING CYCLES DURABILITY : 500 CYCLES MIN.
- 2.8 ROHS COMPLIANT.

3. SUITABLE CONTACTS : 16# & 2.5mm CONTACTS.

4. ALL DIMENSIONS ARE FOR REFERENCE USE ONLY.

5. CONTACT SIZE AND REAR SEAL WIRE RANGE :

CONTACT SIZE	MIN. INSUL O.D.	MAX. INSUL O.D.	WIRE RANGE
16#	Ø2.0mm	Ø3.2mm	14 - 24AWG
2.5mm	Ø3.3mm	Ø4.3mm	14 - 12AWG

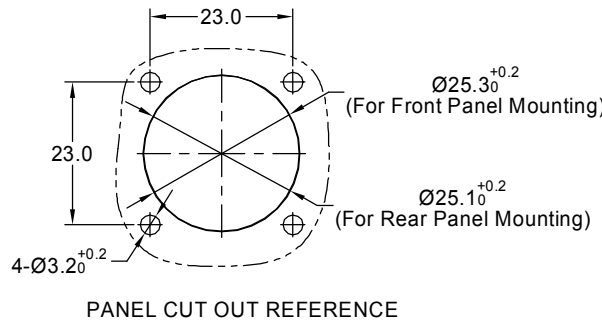

KEY POS	PART NUMBER		A	B	C	D
	-40°C ~ 105°C	-40°C ~ 125°C				
N	RT00142PNHEC	RT00142PNHEC03	105°	140°	215°	265°
W	RT00142PWHEC	RT00142PWHEC03	60°	140°	215°	265°
X	RT00142PXHEC	RT00142PXHEC03	105°	160°	215°	265°
Y	RT00142PYHEC	RT00142PYHEC03	105°	140°	225°	265°
Z	RT00142PZHEC	RT00142PZHEC03	105°	140°	215°	295°

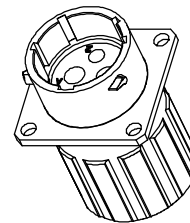

SEE PART NUMBER CHART		DESCRIPTION		ITEM
QUANTITY	PART NUMBER			
<b>MATERIALS LIST</b>				
<b>UNLESS OTHERWISE SPECIFIED</b> 1) All dimensions are in metric(mm). 2) Tolerances are as follows: 1 PL DEC ±0.30 2 PL DEC ±0.15 3 PL DEC ±0.08 Fractions ±1/64 Angles ±1° 3) Note reference =		<b>SIGNATURES</b> DRAWN: <b>Ronald</b> Dec-18-20 CHECKED: <b>Ronald</b> Dec-19-20 ENGINEER: APPROVAL: <b>Tommy</b> Dec-20-20 CUSTOMER:		<b>Amphenol</b> Sine Systems - www.amphenol-sine.com 44724 Morley Drive Clinton Township, MI 48036
MATERIAL SPECIFICATIONS:		THIS DRAWING IS SUPPLIED FOR INFORMATION ONLY. DESIGN FEATURES, SPECIFICATIONS AND PERFORMANCE DATA SHOWN HEREON ARE THE PROPERTY OF THE AMPHENOL CORPORATION. NO RIGHTS OF REPRODUCTION ARE IMPLIED. ALL DIMENSIONS ARE SUBJECT TO NORMAL MANUFACTURING VARIATIONS.		SIZE TYPE DWG NO: <b>B C-</b> <b>RT00142P*HEC</b> <b>B2</b>
PROCESS SPECIFICATIONS:	NEXT ASSY:		SCALE NONE	SHEET 1 OF 1

TITLE: ECOMATE RM,RECEPTACLE,SIZE 14,2+2 POS,PIN,END CAP  
 DWG NO.: RT00142P\*HEC  
 REV: B2  
 SH: 1  
 OF: 1