

TL497A SWITCHING VOLTAGE REGULATORS

SLVS009D – JUNE 1976 – REVISED JULY 1999

- High Efficiency . . . 60% or Greater
- Output Current . . . 500 mA
- Input Current Limit Protection
- TTL-Compatible Inhibit
- Adjustable Output Voltage
- Input Regulation . . . 0.2% Typ
- Output Regulation . . . 0.4% Typ
- Soft Start-Up Capability

D, N, OR PW PACKAGE
(TOP VIEW)

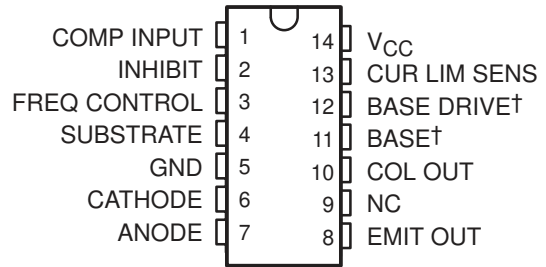

NC – No internal connection

†BASE (11) and BASE DRIVE (12) are used for device testing only. They normally are not used in circuit applications of the device.

description

The TL497A incorporates all the active functions required in the construction of switching voltage regulators. It can also be used as the control element to drive external components for high-power-output applications. The TL497A was designed for ease of use in step-up, step-down, or voltage-inversion applications requiring high efficiency.

The TL497A is a fixed-on-time variable-frequency switching-voltage-regulator control circuit. The switch-on time is programmed by a single external capacitor connected between FREQ CONTROL and GND. This capacitor, C_T , is charged by an internal constant-current generator to a predetermined threshold. The charging current and the threshold vary proportionally with V_{CC} . Thus, the switch-on time remains constant over the specified range of input voltage (4.5 V to 12 V). Typical on times for various values of C_T are as follows:

TIMING CAPACITOR, C_T (pF)	200	250	350	400	500	750	1000	1500	2000
ON TIME (μ s)	19	22	26	32	44	56	80	120	180

The output voltage is controlled by an external resistor ladder network (R_1 and R_2 in Figures 1, 2, and 3) that provides a feedback voltage to the comparator input. This feedback voltage is compared to the reference voltage of 1.2 V (relative to SUBSTRATE) by the high-gain comparator. When the output voltage decays below the value required to maintain 1.2 V at the comparator input, the comparator enables the oscillator circuit, which charges and discharges C_T as described above. The internal pass transistor is driven on during the charging of C_T . The internal transistor can be used directly for switching currents up to 500 mA. Its collector and emitter are uncommitted, and it is current driven to allow operation from the positive supply voltage or ground. An internal Schottky diode matched to the current characteristics of the internal transistor also is available for blocking or commutating purposes. The TL497A also has on-chip current-limit circuitry that senses the peak currents in the switching regulator and protects the inductor against saturation and the pass transistor against overstress. The current limit is adjustable and is programmed by a single sense resistor, R_{CL} , connected between V_{CC} and CUR LIM SENS. The current-limit circuitry is activated when 0.7 V is developed across R_{CL} . External gating is provided by the INHIBIT input. When the INHIBIT input is high, the output is turned off.

Simplicity of design is a primary feature of the TL497A. With only six external components (three resistors, two capacitors, and one inductor), the TL497A operates in numerous voltage-conversion applications (step-up, step-down, invert) with as much as 85% of the source power delivered to the load. The TL497A replaces the TL497 in all applications.

The TL497AC is characterized for operation from 0°C to 70°C. The TL497AI is characterized for operation from -40°C to 85°C.



Please be aware that an important notice concerning availability, standard warranty, and use in critical applications of Texas Instruments semiconductor products and disclaimers thereto appears at the end of this data sheet.

PRODUCTION DATA information is current as of publication date. Products conform to specifications per the terms of Texas Instruments standard warranty. Production processing does not necessarily include testing of all parameters.

 **TEXAS
INSTRUMENTS**

POST OFFICE BOX 655303 • DALLAS, TEXAS 75265

Copyright © 1999, Texas Instruments Incorporated

TL497A SWITCHING VOLTAGE REGULATORS

SLVS009D – JUNE 1976 – REVISED JULY 1999

AVAILABLE OPTIONS

T _A	PACKAGED DEVICES			CHIP FORM (Y)
	SMALL-OUTLINE (D)	PLASTIC DIP (N)	SHRINK SMALL-OUTLINE (PW)	
0°C to 70°C	TL497ACD	TL497ACN	TL497ACPW	TL497AY
-40°C to 85°C	TL497AID	TL497AIN	—	—

The D and PW packages are only taped and reeled. Add the suffix R to the device type (e.g., TL497ACPWR). Chip forms are tested at 25°C.

functional block diagram

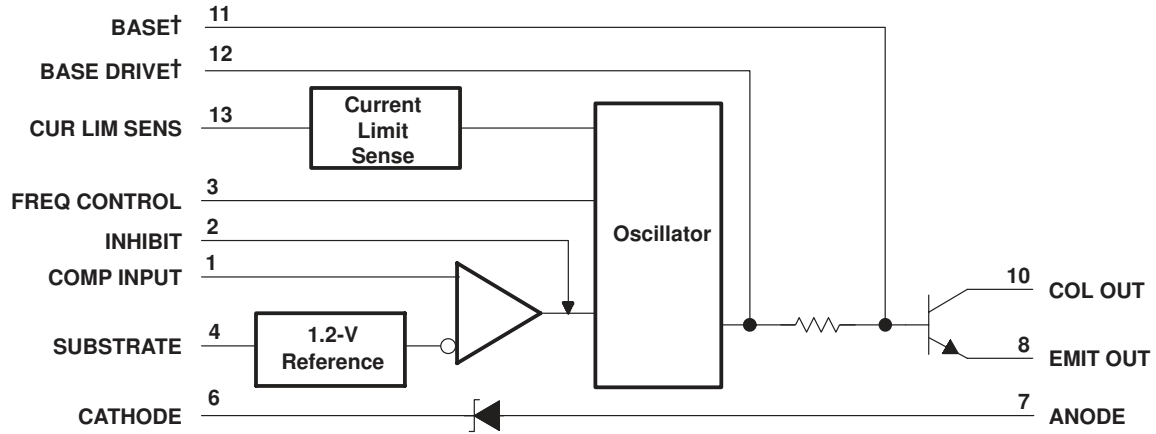

† BASE and BASE DRIVE are used for device testing only. They normally are not used in circuit applications of the device.

TL497A SWITCHING VOLTAGE REGULATORS

SLVS009D – JUNE 1976 – REVISED JULY 1999

absolute maximum ratings over operating free-air temperature range (unless otherwise noted)†

Supply voltage, V_{CC} (see Note 1)	15 V
Output voltage, V_O	35 V
Input voltage, V_I (COMP INPUT)	5 V
Input voltage, V_I (INHIBIT)	5 V
Diode reverse voltage	35 V
Power switch current	750 mA
Diode forward current	750 mA
Package thermal impedance, θ_{JA} (see Notes 2 and 3): D package	86°C/W
N package	101°C/W
PW package	113°C/W
Lead temperature 1,6 mm (1/16 inch) from case for 60 seconds	260°C
Storage temperature range, T_{stg}	–65°C to 150°C

†Stresses beyond those listed under “absolute maximum ratings” may cause permanent damage to the device. These are stress ratings only, and functional operation of the device at these or any other conditions beyond those indicated under “recommended operating conditions” is not implied. Exposure to absolute-maximum-rated conditions for extended periods may affect device reliability.

- NOTES:
1. All voltage values except diode voltages are with respect to network ground terminal.
 2. Maximum power dissipation is a function of $T_J(\max)$, θ_{JA} , and T_A . The maximum allowable power dissipation at any allowable ambient temperature is $P_D = (T_J(\max) - T_A)/\theta_{JA}$. Operating at the absolute maximum T_J of 150°C can impact reliability.
 3. The package thermal impedance is calculated in accordance with JESD 51, except for through-hole packages, which use a trace length of zero.

recommended operating conditions

		MIN	MAX	UNIT	
Supply voltage, V_{CC}		4.5	12	V	
High-level input voltage, V_{IH}	INHIBIT pin	2.5		V	
Low-level input voltage, V_{IL}	INHIBIT pin		0.8	V	
Output voltage	Step-up configuration (see Figure 1)	$V_I + 2$	30	V	
	Step-down configuration (see Figure 2)	V_{ref}	$V_I - 1$		
	Inverting regulator (see Figure 3)	$-V_{ref}$	–25		
Power switch current			500	mA	
Diode forward current			500	mA	
Operating free-air temperature range, T_A		TL497AC	0	70	°C
		TL497AI	–40	85	



TL497A

SWITCHING VOLTAGE REGULATORS

SLVS009D – JUNE 1976 – REVISED JULY 1999

electrical characteristics over recommended operating conditions, $V_{CC} = 6\text{ V}$ (unless otherwise noted)

PARAMETER	TEST CONDITIONS	T_A †	TL497AC			TL497AI			UNIT
			MIN	TYP‡	MAX	MIN	TYP‡	MAX	
High-level input current, INHIBIT	$V_{I(I)} = 5\text{ V}$	Full range	0.8	1.5		0.8	1.5	mA	
Low-level input current, INHIBIT	$V_{I(I)} = 0\text{ V}$	Full range	5	10		5	20	μA	
Comparator reference voltage	$V_I = 4.5\text{ V to }6\text{ V}$	Full range	1.08	1.2	1.32	1.14	1.2	1.26	V
Comparator input bias current	$V_I = 6\text{ V}$	Full range	40	100		40	100	μA	
Switch on-state voltage	$V_I = 4.5\text{ V}$	$I_O = 100\text{ mA}$	25°C	0.13	0.2	0.13	0.2	V	
		$I_O = 500\text{ mA}$	Full range	0.85		1			
Switch off-state current	$V_I = 4.5\text{ V}, V_O = 30\text{ V}$	25°C	10	50		10	50	μA	
		Full range	200		500				
Sense voltage, CUR LIM SENS	$V_I = 6\text{ V}$	25°C	0.45	1		0.45	1	V	
Diode forward voltage	$I_O = 10\text{ mA}$	Full range	0.75	0.85		0.75	0.95	V	
	$I_O = 100\text{ mA}$	Full range	0.9	1		0.9	1.1		
	$I_O = 500\text{ mA}$	Full range	1.33	1.55		1.33	1.75		
Diode reverse voltage	$I_O = 500\text{ }\mu\text{A}$	Full range			30		V		
	$I_O = 200\text{ }\mu\text{A}$	Full range	30						
On-state supply current		25°C	11	14		11	14	mA	
		Full range	15		16				
Off-state supply current		25°C	6	9		6	9	mA	
		Full range	10		11				

† Full range is 0°C to 70°C for the TL497AC and –40°C to 85°C for the TL497AI.

‡ All typical values are at $T_A = 25^\circ\text{C}$.

electrical characteristics over recommended operating conditions, $V_{CC} = 6\text{ V}$, $T_A = 25^\circ\text{C}$ (unless otherwise noted)

PARAMETER	TEST CONDITIONS	TL497AY			UNIT
		MIN	TYP	MAX	
High-level input current, INHIBIT	$V_{I(I)} = 5\text{ V}$	0.8			mA
Low-level input current, INHIBIT	$V_{I(I)} = 0\text{ V}$	5			μA
Comparator reference voltage	$V_I = 4.5\text{ V to }6\text{ V}$	1.2			V
Comparator input bias current	$V_I = 6\text{ V}$	40			μA
Switch on-state voltage	$V_I = 4.5\text{ V}, I_O = 100\text{ mA}$	0.13			V
Switch off-state current	$V_I = 4.5\text{ V}, V_O = 30\text{ V}$	10			μA
Diode forward voltage	$I_O = 10\text{ mA}$	0.75			V
	$I_O = 100\text{ mA}$	0.9			
	$I_O = 500\text{ mA}$	1.33			
On-state supply current		11			mA
Off-state supply current		6			mA



APPLICATION INFORMATION

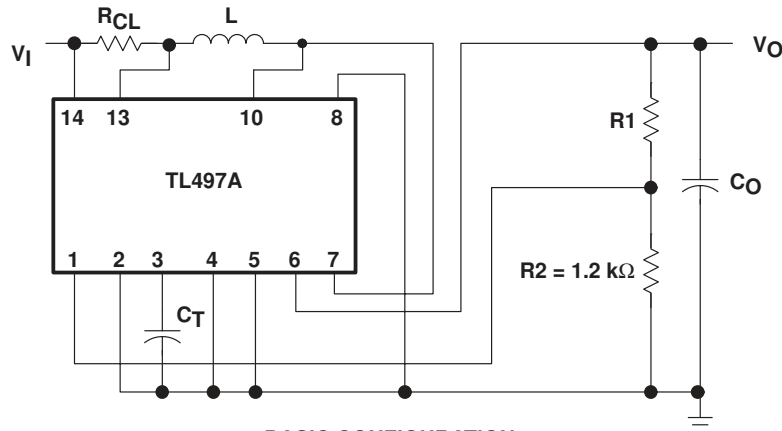

BASIC CONFIGURATION
(Peak Switching Current = $I_{(PK)} < 500 \text{ mA}$)

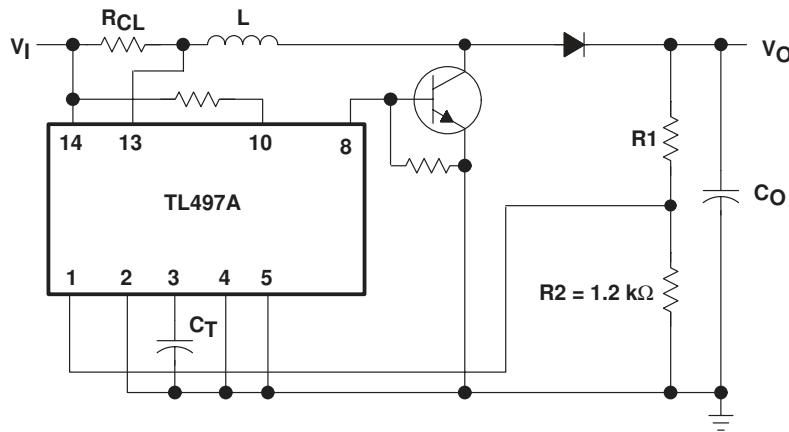

EXTENDED POWER CONFIGURATION
(using external transistor)

DESIGN EQUATIONS

- $I_{(PK)} = 2 I_O \max \left[\frac{V_O}{V_I} \right]$

- $L (\mu\text{H}) = \frac{V_I}{I_{(PK)}} t_{on} (\mu\text{s})$

Choose L (50 to 500 μH), calculate t_{on} (25 to 150 μs)

- $C_T (\text{pF}) \approx 12 t_{on} (\mu\text{s})$

- $R_1 = (V_O - 1.2 \text{ V}) \text{ k}\Omega$

- $R_{CL} = \frac{0.5 \text{ V}}{I_{(PK)}}$

- $C_O (\mu\text{F}) \approx t_{on} (\mu\text{s}) \frac{\left[\frac{V_I}{V_O} I_{(PK)} + I_O \right]}{V_{\text{ripple (PK)}}$

Figure 1. Positive Regulator, Step-Up Configurations

TL497A SWITCHING VOLTAGE REGULATORS

SLVS009D – JUNE 1976 – REVISED JULY 1999

APPLICATION INFORMATION

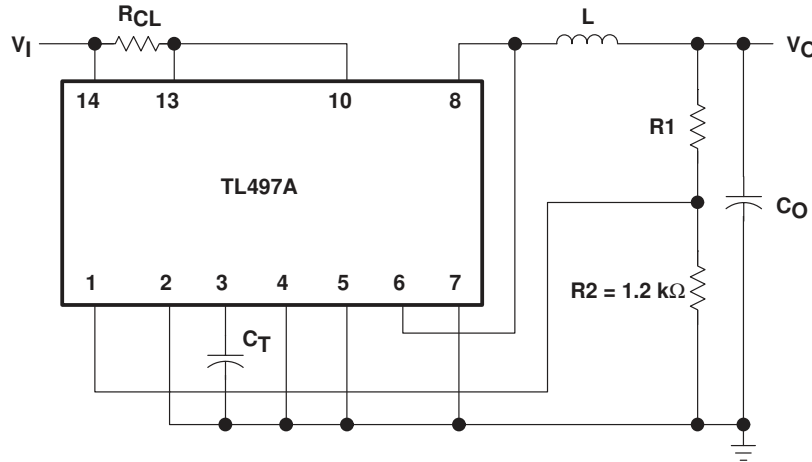

BASIC CONFIGURATION
(Peak Switching Current = $I_{(PK)} < 500 \text{ mA}$)

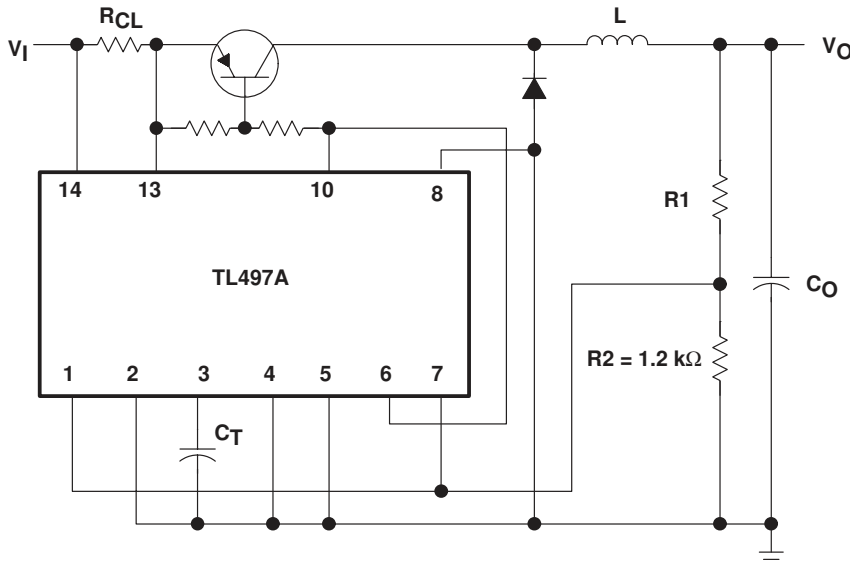

EXTENDED POWER CONFIGURATION
(using external transistor)

DESIGN EQUATIONS

- $I_{(PK)} = 2 I_{O \text{ max}}$

- $L (\mu\text{H}) = \frac{V_I - V_O}{I_{(PK)}} t_{on}(\mu\text{s})$

Choose L (50 to 500 μH), calculate t_{on} (10 to 150 μs)

- $C_T(\text{pF}) \approx 12 t_{on}(\mu\text{s})$

- $R1 = (V_O - 1.2 \text{ V}) \text{ k}\Omega$

- $R_{CL} = \frac{0.5 \text{ V}}{I_{(PK)}}$

- $C_O (\mu\text{F}) \approx t_{on}(\mu\text{s}) \frac{\left[\frac{V_I - V_O}{V_O} I_{(PK)} + I_O \right]}{V_{\text{ripple}}(\text{PK})}$

Figure 2. Positive Regulator, Step-Down Configurations

APPLICATION INFORMATION

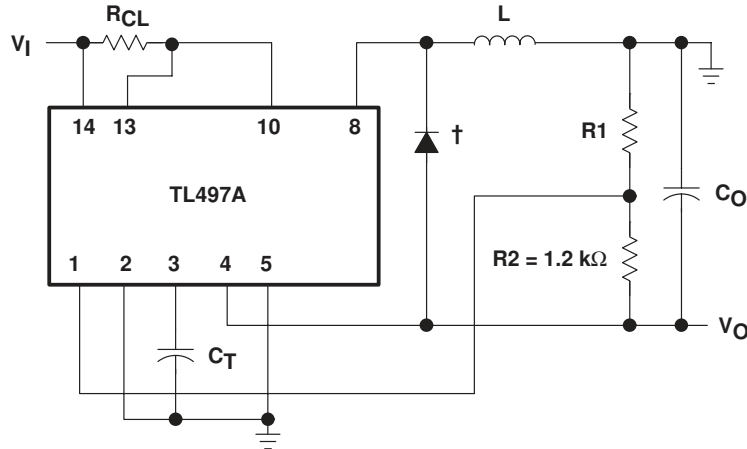

BASIC CONFIGURATION
(Peak Switching Current = $I_{(PK)} < 500$ mA)

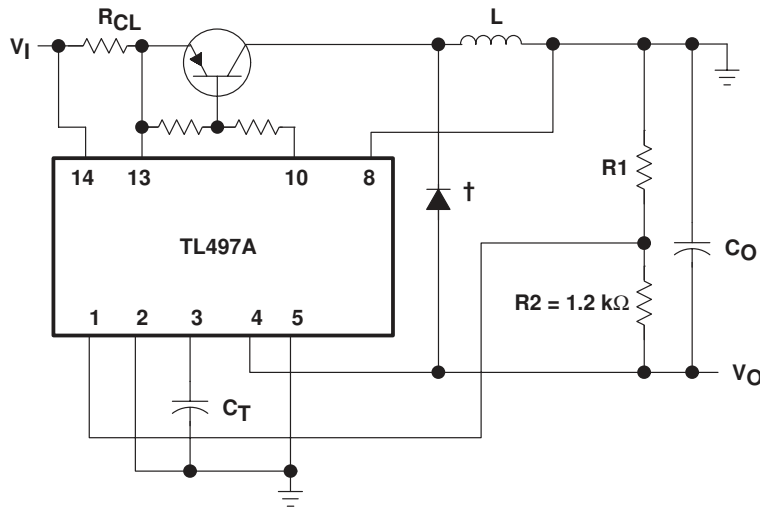

EXTENDED POWER CONFIGURATION
(using external transistor)

† Use external catch diode, e.g., 1N4001, when building an inverting supply with the TL497A.

DESIGN EQUATIONS

- $I_{(PK)} = 2 I_O \max \left[1 + \frac{|V_O|}{V_I} \right]$

- $L (\mu H) = \frac{V_I}{I_{(PK)}} t_{on}(\mu s)$

Choose L (50 to 500 μH), calculate t_{on} (10 to 150 μs)

- $C_T(pF) \approx 12 t_{on}(\mu s)$

- $R1 = (|V_O| - 1.2 V) k\Omega$

$$R_{CL} = \frac{0.5 V}{I_{(PK)}}$$

- $C_O (\mu F) \approx t_{on}(\mu s) \frac{\left[\frac{V_I}{|V_O|} I_{(PK)} + I_O \right]}{V_{ripple (PK)}}$

Figure 3. Inverting Applications

TL497A SWITCHING VOLTAGE REGULATORS

SLVS009D – JUNE 1976 – REVISED JULY 1999

APPLICATION INFORMATION

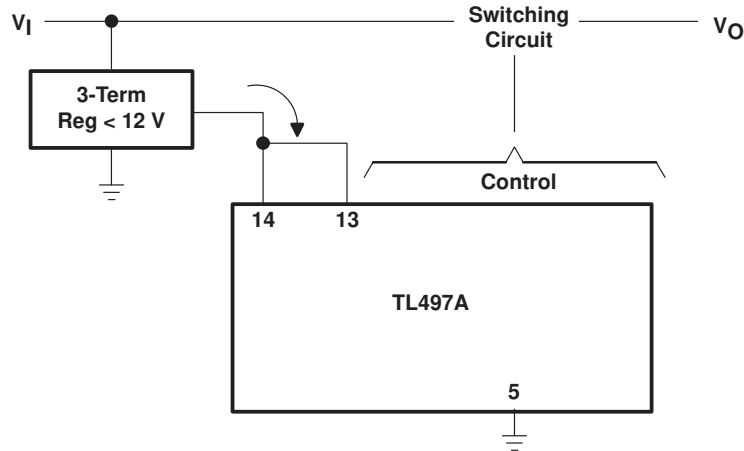

EXTENDED INPUT CONFIGURATION WITHOUT CURRENT LIMIT

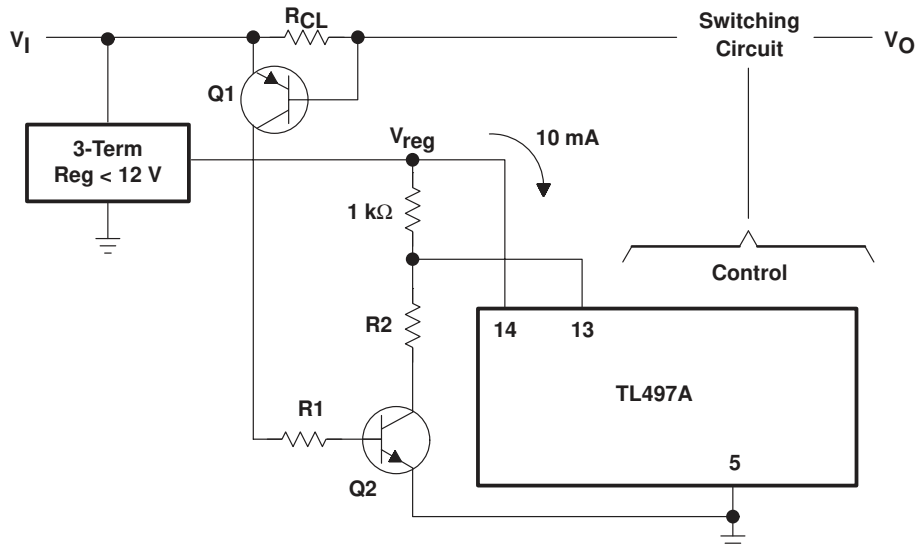

DESIGN EQUATIONS

- $R_{CL} = \frac{V_{BE(Q1)}}{I_{limit}(PK)}$
- $R1 = \frac{V_1}{I_B(Q2)}$
- $R2 = (V_{reg} - 1) 10 \text{ k}\Omega$

CURRENT LIMIT FOR EXTENDED INPUT CONFIGURATION

Figure 4. Extended Input Voltage Range ($V_1 > 12 \text{ V}$)

IMPORTANT NOTICE

Texas Instruments and its subsidiaries (TI) reserve the right to make changes to their products or to discontinue any product or service without notice, and advise customers to obtain the latest version of relevant information to verify, before placing orders, that information being relied on is current and complete. All products are sold subject to the terms and conditions of sale supplied at the time of order acknowledgement, including those pertaining to warranty, patent infringement, and limitation of liability.

TI warrants performance of its semiconductor products to the specifications applicable at the time of sale in accordance with TI's standard warranty. Testing and other quality control techniques are utilized to the extent TI deems necessary to support this warranty. Specific testing of all parameters of each device is not necessarily performed, except those mandated by government requirements.

CERTAIN APPLICATIONS USING SEMICONDUCTOR PRODUCTS MAY INVOLVE POTENTIAL RISKS OF DEATH, PERSONAL INJURY, OR SEVERE PROPERTY OR ENVIRONMENTAL DAMAGE ("CRITICAL APPLICATIONS"). TI SEMICONDUCTOR PRODUCTS ARE NOT DESIGNED, AUTHORIZED, OR WARRANTED TO BE SUITABLE FOR USE IN LIFE-SUPPORT DEVICES OR SYSTEMS OR OTHER CRITICAL APPLICATIONS. INCLUSION OF TI PRODUCTS IN SUCH APPLICATIONS IS UNDERSTOOD TO BE FULLY AT THE CUSTOMER'S RISK.

In order to minimize risks associated with the customer's applications, adequate design and operating safeguards must be provided by the customer to minimize inherent or procedural hazards.

TI assumes no liability for applications assistance or customer product design. TI does not warrant or represent that any license, either express or implied, is granted under any patent right, copyright, mask work right, or other intellectual property right of TI covering or relating to any combination, machine, or process in which such semiconductor products or services might be or are used. TI's publication of information regarding any third party's products or services does not constitute TI's approval, warranty or endorsement thereof.



>> [Semiconductor Home](#) > [Products](#) > [Analog & Mixed-Signal](#) > [Power Management](#) > [Switching Power Supply Controllers](#) > [Voltage Mode](#)
>

TL497A, SWITCHING VOLTAGE REGULATOR

Device Status: Active

- > Description
- > Features
- > Datasheets
- > Pricing/Samples/Availability
- > Application Notes
- > Development Tools
- > Applications

Parameter Name	TL497A
Shutdown	Yes
Pulse - by - Pulse Isense	No
Vsupply Operating Range (V)	4.5-12
Output Type	Single Switch
Output Current (mA)	500
Frequency (max) (kHz)	50
Operating / Standby Current (mA)	11/6
Reference Voltage (V)	1.2
Vref tol (%)	5
Undervoltage Lockout	No
On-board Amplifiers	1
Output Mode Fixed Push - Pull	No
Output Mode Single - Ended	Yes
Programmable Outputs	No
Current - Sense Amplifiers	1
Dead Time Control	No

Description

The TL497A incorporates all the active functions required in the construction of switching voltage regulators. It can also be used as the control element to drive external components for high-power-output applications. The TL497A was designed for ease of use in step-up, step-down, or voltage-inversion applications requiring high efficiency.

The TL497A is a fixed-on-time variable-frequency switching-voltage-regulator control circuit. The switch-on time is programmed by a single external capacitor connected between **FREQ CONTROL** and **GND**. This capacitor, C_T , is charged by an internal constant-current generator to a predetermined threshold. The charging current and the threshold vary proportionally with V_{CC} . Thus, the switch-on time remains constant over the specified range of input voltage (4.5 V to 12 V). Typical on times for various values of C_T are as follows:

The output voltage is controlled by an external resistor ladder network (R1 and R2 in Figures 1, 2, and 3) that provides a feedback voltage to the comparator input. This feedback voltage is compared to the reference voltage of 1.2 V (relative to SUBSTRATE) by the high-gain comparator. When the output voltage decays below the value required to maintain 1.2 V at the comparator input, the comparator enables the oscillator circuit, which charges and discharges C_T as described above. The internal pass transistor is driven on during the charging of C_T . The internal transistor can be used directly for switching currents up to 500 mA. Its collector and emitter are uncommitted, and it is current driven to allow operation from the positive supply voltage or ground. An internal Schottky diode matched to the current characteristics of the internal transistor also is available for blocking or commutating purposes. The TL497A also has on-chip current-limit circuitry that senses the peak currents in the switching regulator and protects the inductor against saturation and the pass transistor against overstress. The current limit is adjustable and is programmed by a single sense resistor, R_{CL} , connected between V_{CC} and CUR LIM SENS. The current-limit circuitry is activated when 0.7 V is developed across R_{CL} . External gating is provided by the INHIBIT input. When the INHIBIT input is high, the output is turned off.

Simplicity of design is a primary feature of the TL497A. With only six external components (three resistors, two capacitors, and one inductor), the TL497A operates in numerous voltage-conversion applications (step-up, step-down, invert) with as much as 85% of the source power delivered to the load. The TL497A replaces the TL497 in all applications.

The TL497AC is characterized for operation from 0°C to 70°C. The TL497AI is characterized for operation from -40°C to 85°C.

Features

- High Efficiency...60% or Greater
- Output Current...500 mA
- Input Current Limit Protection
- TTL-Compatible Inhibit
- Adjustable Output Voltage
- Input Regulation...0.2% Typ
- Output Regulation...0.4% Typ
- Soft Start-Up Capability

To view the following documents, [Acrobat Reader 3.x](#) is required.

To download a document to your hard drive, right-click on the link and choose 'Save'.

Datasheets

Full datasheet in Acrobat PDF: [slvs009d.pdf](#) (137 KB)

Full datasheet in Zipped PostScript: [slvs009d.psz](#) (128 KB)

Pricing/Samples/Availability

Orderable Device	Package	Pins	Temp (°C)	Status	Price/unit USD (100-999)	Pack Qty	Availability / Samples
TL497ACD	<u>D</u>	14		ACTIVE	2.00	50	Check stock or order
TL497ACDR	<u>D</u>	14		ACTIVE	1.70	2500	Check stock or order
TL497ACN	<u>N</u>	14		ACTIVE	1.90	25	Check stock or order
TL497ACNS	<u>NS</u>	14		ACTIVE			Check stock or order
TL497ACNSLE	<u>NS</u>	14		OBSOLETE			
TL497ACPWR	<u>PW</u>	14		ACTIVE	1.59	2000	Check stock or order
TL497AID	<u>D</u>	14		ACTIVE	3.00	50	Check stock or order
TL497AIDR	<u>D</u>	14		ACTIVE	2.51	2500	Check stock or order
TL497AIJ	<u>J</u>	14		OBSOLETE			
TL497AIN	<u>N</u>	14		ACTIVE	3.00	25	Check stock or order

Application Reports

- [ANALOG APPLICATIONS JOURNAL \(SLYT012A, 782 KB\)](#)
- [ANALOG APPLICATIONS JOURNAL \(SLYT010A\)](#)
- [ELECTROSTATIC DISCHARGE APPLICATION NOTE \(SSYA008\)](#)
- [THERMAL CHARACTERISTICS OF LINEAR AND LOGIC PACKAGES USING JEDEC PCB DESIGNS \(SZZA017A\)](#)
- [UNDERSTANDING BOOST POWER STAGES IN SWITCHMODE POWER SUPPLIES \(SLVA061\)](#)
- [UNDERSTANDING BUCK POWER STAGES IN SWITCHMODE POWER SUPPLIES \(SLVA057\)](#)
- [UNDERSTANDING BUCK-BOOST POWER STAGES IN SWITCHMODE POWER SUPPLIES \(SLVA059\)](#)

Table Data Updated on: 4/26/2000

Search	Tech Support	Comments	Site Map	TI2ME	Home
------------------------	------------------------------	--------------------------	--------------------------	-----------------------	----------------------

(c) Copyright 2000 Texas Instruments Incorporated. All rights reserved.

[Trademarks](#), [Important Notice!](#), [Privacy Policy](#)