

THIS DRAWING CONTAINS INFORMATION PROPRIETARY TO RF INDUSTRIES,
 ANY UNAUTHORIZED USE OF THIS DRAWING IS EXPRESSLY PROHIBITED
 WITHOUT WRITTEN PERMISSION FROM RF INDUSTRIES.
 ANY VIOLATION IS PUNISHABLE UNDER U.S. COPYRIGHT LAWS.

ALL DIMENSIONS ARE REFERENCE ONLY

PART NO.

RFB-1707-S

REV	DESCRIPTION	DWN	DATE	APPROVED
-	ENGINEERING RELEASE	CZS	09/08/00	JDMc
A	CHANGED STRIP DIMENSIONS FOR CABLE	JDM	5/1/08	JDMc

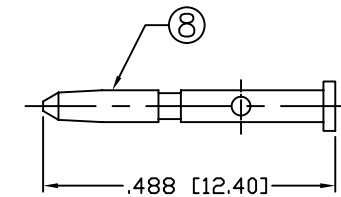
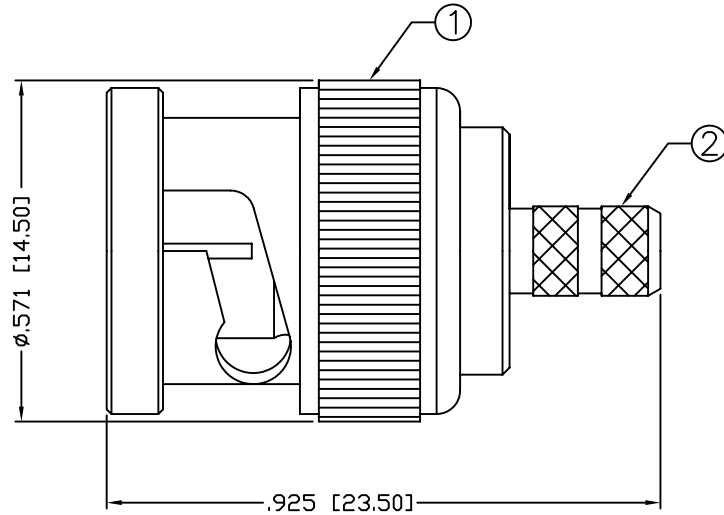

SOLDER OR USE CRIMP DIE .042

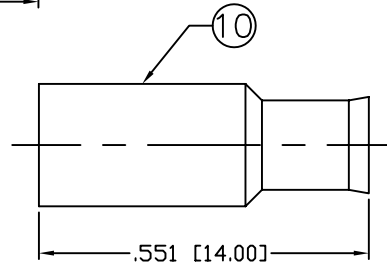
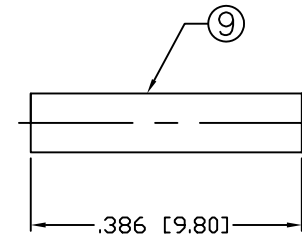

RECOMMENDED CRIMP DIE .178

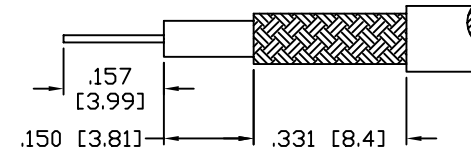

RECOMMENDED STRIPPING DIMENSIONS

SPECIFICATIONS:

IMPEDANCE: 75 Ohms
 FREQUENCY RANGE: 0-4 GHz
 WORKING VOLTAGE: 500 V rms @ sea level
 TEMPERATURE RANGE: -65°C TO 85°C
 INSULATION RESISTANCE: 5k M Ohms min.
 FOR RG-161, 179, 179A, 187 & 187A/U CABLE

#	DESCRIPTION	QTY	MATRL	FINISH	APPROVALS	DATE
1	SHELL	1	BRASS	NICKEL, 100μ"	008974	5/1/08
2	BODY	1	BRASS	NICKEL, 100μ"		
3	INSULATOR	1	PTFE	----		
4	GASKET	1	RUBBER	RED		
5	RETAINING RING	1	BRASS	NICKEL, 100μ"		
6	SPRING	1	SK5	NICKEL, 100μ"		
7	WASHER	1	BRASS	NICKEL, 100μ"		
8	PIN	1	BRASS	GOLD, 3μ"		
9	SLEEVE	1	DELRIN	----		
10	FERRULE	1	BRASS	NICKEL, 100μ"		
11						
12						
13						
14						

UNLESS OTHERWISE SPECIFIED:
 1. REMOVE ALL BURRS
 2. BREAK ALL CORNERS & EDGES .005 R. MAX.
 3. CHAMFER 1ST & LAST THREADS 45°
 4. SURFACE ROUGHNESS 63 FINISH MIL-STD-10
 5. DIAMETERS ON COMMON CENTERS TO BE CONCENTRIC WITHIN .002 T.I.R.
 6. ALL DIMENSIONS ARE AFTER PLATING.

DIMENSIONS ARE IN INCHES AND [MILLIMETERS]
 UNLESS OTHERWISE NOTED TOLERANCES ARE:
 DECIMALS DIAMETER
 .xxx±.003 [.08] .xxx±.001 [.03]
 .xx±.005 [.13] .xx±.003 [.08]



7610 MIRAMAR RD
 SAN DIEGO, CA 92126
 (858) 549-6340
 (858) 549-6345 FAX

BNC PLUG, CRIMP

75 OHM

SIZE	CABLE GROUP	DWG NO.	REV
A	S	RFB-1707-S	A
SCALE:	NTS	CAD FILE	OUTLINE
SHEET		1 OF 1	