

Technical Data
 Material:
 Pin: Brass, machined CuZn38Pb2
 Plating: Gold Flash, 80u"Ni
 Insulator : PA6T+30%GF (Black, UL94V-0) High Temp
 Packing: Tape&Reel
 Soldering Temperature:+260° /10S Max

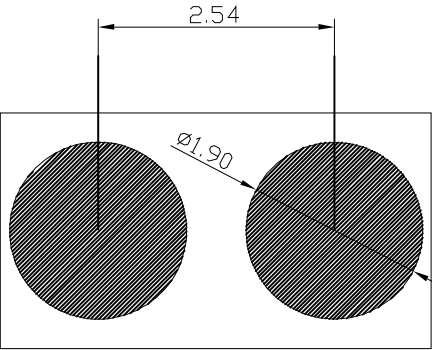

P.C.B LAYOUT

RoHS compliant

Unit:mm

Scale	Free					Date	Name	Customer-No.
TOLERANCE					Drawn	28.05.2013	Winnie	
X.	±0.20				Approved	28.05.2013	Winnie	ASSMANN WSW-No. ADP-254-02-SR
X.X	±0.15							
X.XX	±0.10							
X.XXX	±0.05							
DIM	TOL							Drawing-No. ASS 5717 CO
Angle	±5°	①	Drawn	28.05.2013				Winnie
		Id.	Modification	Date	Name	Replace	SHEET 1/3	

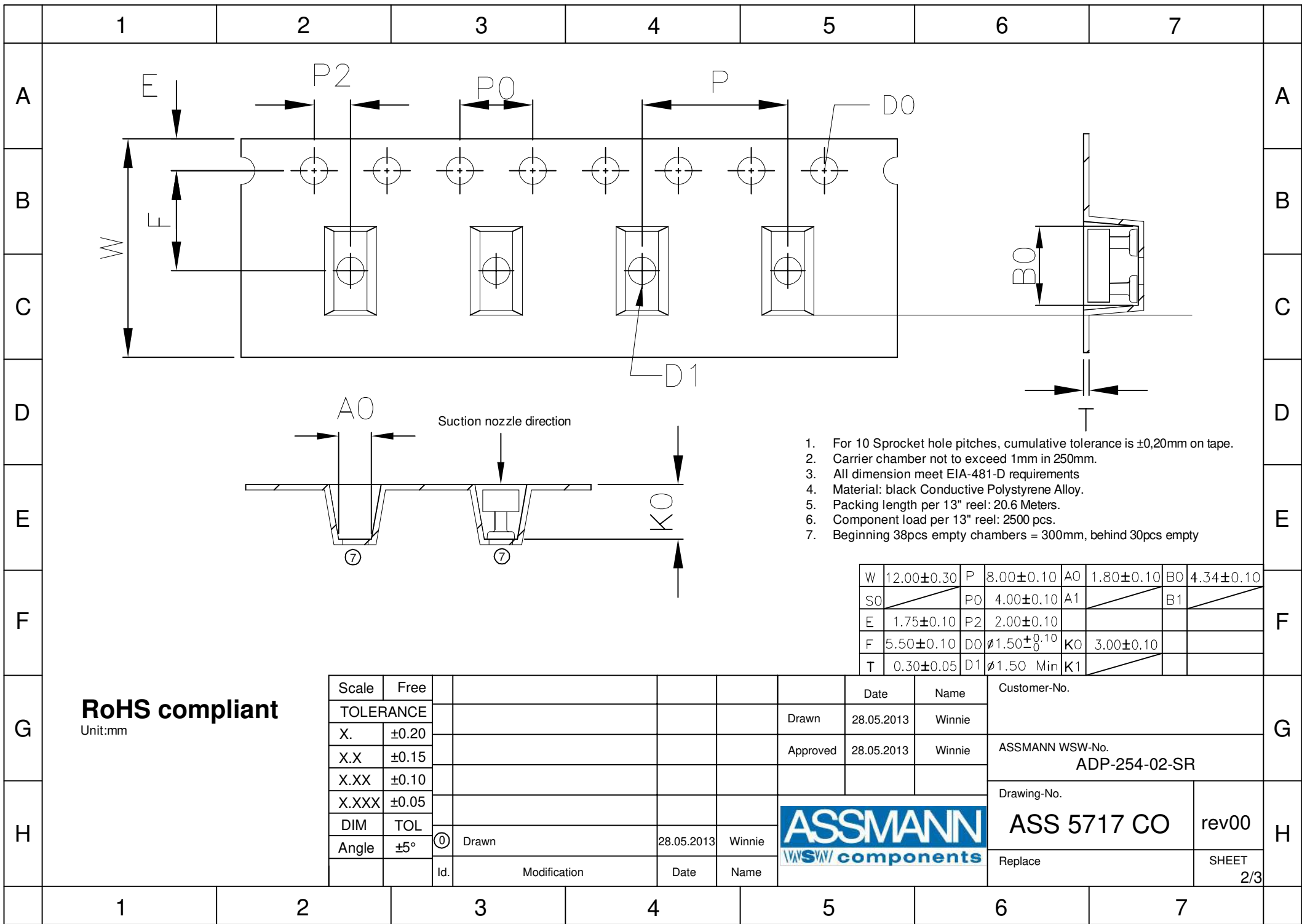

1. For 10 Sprocket hole pitches, cumulative tolerance is $\pm 0,20\text{mm}$ on tape.
2. Carrier chamber not to exceed 1mm in 250mm.
3. All dimension meet EIA-481-D requirements
4. Material: black Conductive Polystyrene Alloy.
5. Packing length per 13" reel: 20.6 Meters.
6. Component load per 13" reel: 2500 pcs.
7. Beginning 38pcs empty chambers = 300mm, behind 30pcs empty

W	12.00 ± 0.30	P	8.00 ± 0.10	A0	1.80 ± 0.10	B0	4.34 ± 0.10
S0		P0	4.00 ± 0.10	A1		B1	
E	1.75 ± 0.10	P2	2.00 ± 0.10				
F	5.50 ± 0.10	D0	$\phi 1.50 \pm 0.10$	K0	3.00 ± 0.10		
T	0.30 ± 0.05	D1	$\phi 1.50$ Min	K1			

RoHS compliant
Unit:mm

Scale	Free
TOLERANCE	
X.	± 0.20
X.X	± 0.15
X.XX	± 0.10
X.XXX	± 0.05
DIM	TOL
Angle	$\pm 5^\circ$

Drawn	28.05.2013	Winnie
Approved	28.05.2013	Winnie
Id.	Modification	Date
		Name

Date: 28.05.2013
Name: Winnie

Drawn: 28.05.2013
Approved: 28.05.2013
Winnie

Customer-No.	
ASSMANN WSW-No. ADP-254-02-SR	
Drawing-No.	ASS 5717 CO
Replace	rev00
SHEET 2/3	

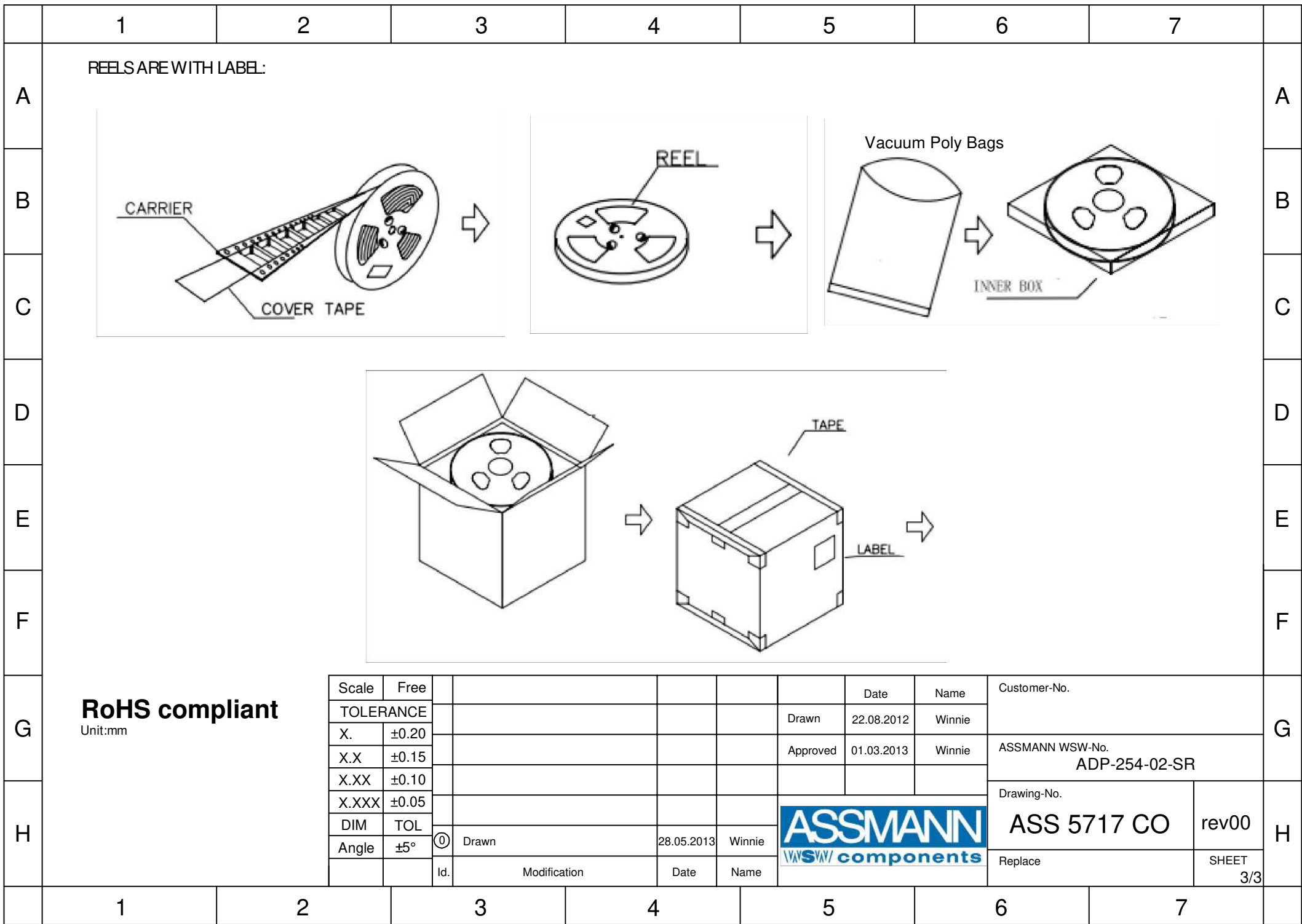

RoHS compliant
Unit:mm

Scale	Free					Date	Name	Customer-No.
TOLERANCE						Drawn	22.08.2012	Winnie
X.	±0.20					Approved	01.03.2013	Winnie
X.X	±0.15							ASSMANN WSW-No. ADP-254-02-SR
X.XX	±0.10							Drawing-No.
X.XXX	±0.05							ASS 5717 CO
DIM	TOL	①	Drawn	28.05.2013	Winnie			rev00
Angle	±5°	Id.	Modification	Date	Name			Replace