



Application note

1.88-1.93 GHz DECT ANTENNA

*10 x 3.2 x 2.0 mm Ceramic Chip Antenna
(Ground Cleared Under Antenna 10.80 x 6.25 mm)*

Pulse Part Number: W3022

Status

Author	JaP	Version	2.0.1
Checked by	MHa	Date	2008.04.25
Approved by	KiKo	Date	2008.04.25

Table of Content

W3022 1.88-1.93 GHZ DECT ANTENNA GENERAL FEATURES AND APPLICATIONS.....	3
FEATURES.....	3
APPLICATIONS.....	3
ELECTRICAL SPECIFICATIONS@+25 °C.....	3
W3022 1.88-1.93 GHZ DECT ANTENNA TERMINAL CONFIGURATION AND DIMENSIONS.....	4
W3022 1.88-1.93 GHZ DECT ANTENNA PWB LAYOUT SPECIFICATIONS.....	5
PWB LAYOUT FOR W3022 1.88-1.93 GHZ DECT ANTENNA.....	5
GROUND CLEARANCE AREA FOR W3022 1.88-1.93 GHZ DECT ANTENNA.....	6
PWB PAD DIMENSIONS AND ANTENNA POSITION FOR W3022 1.88-1.93 GHZ DECT ANTENNA.....	7
TYPICAL GROUND VIA HOLE PLACEMENT IN PWB LAYOUT FOR W3022 1.88-1.93 GHZ DECT ANTENNA.....	8
SOLDER RESIST OPENING AND PASTE STENCIL RECOMMENDATION FOR W3022 1.88-1.93 GHZ DECT ANTENNA.....	8
RECOMMENDED ANTENNA POSITION ON PWB FOR W3022 1.88-1.93 GHZ DECT ANTENNA.....	9
W3022 1.88-1.93 GHZ DECT ANTENNA TEST SET UP AND MEASUREMENT PERFORMANCE.....	10
TYPICAL ELECTRICAL CHARACTERISTICS (T=25°C).....	10
TYPICAL FREE SPACE RADIATION PATTERNS.....	11
W3022 1.88-1.93 GHZ DECT ANTENNA PACKING.....	12
GENERAL.....	12
CARRIER TAPE.....	12
BLOCK ORIENTATION.....	13
PACKING FORM.....	14
W3022 1.88-1.93 GHZ DECT ANTENNA.....	15
MECHANICAL OUTLINE.....	15
CONTACT INFORMATION.....	16

W3022 1.88-1.93 GHz DECT Antenna General Features and Applications

Ground cleared under antenna, clearance area **10.80 x 6.25 mm**

Features

- Omni directional radiation
- Low profile
- Compact size W x L x H (10 x 3.2 x 2 mm)
- Low weight (310 mg)
- Lead free materials
- Fully SMD compatible
- Lead free soldering compatible
- Tape and reel packing
- RoHS compliant product



Applications

- DECT bands (European + US)
- 1.88 –1.93 GHz

Electrical specifications @+25 °C

Note: Electrical characteristics depend on test board (GP) size and antenna positioning on GP and ground clearance area size.

1.88 –1.93 GHz DECT

Typical performance

(Test board size 80 x 37 mm, PWB ground clearance area **10.80 x 6.25 mm**, position 1 on **PWB**, see Page 9)

Frequency Range [MHz]	Linear Max Gain [dBi]	Efficiency [%] / [dB]	Return loss min. [dB]	Impedance [Ω]	Operating Temperature [°C]
1880 – 1930	2.5 (peak) 2.0 (band edges)	80 / -1 (peak) 70 / -1,55 (band edges)	-12	50	-40 to +85

W3022 1.88-1.93 GHz DECT antenna terminal configuration and dimensions

Ground cleared under antenna, clearance area 10.80 x 6.25 mm

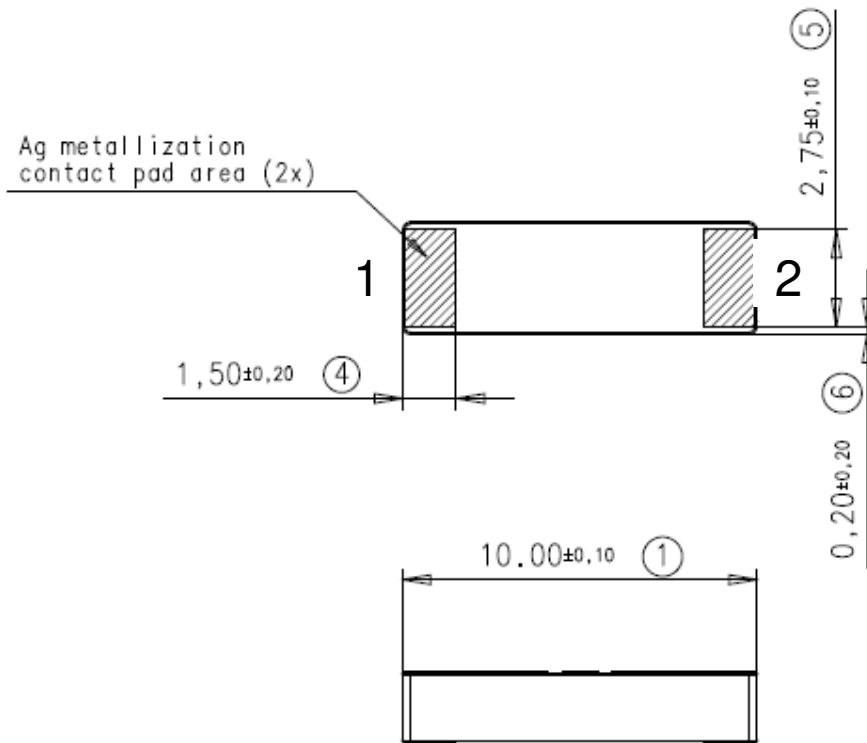

No.	Terminal Name	Terminal Dimensions
1	Feed / GND	1.5 x 2.75 mm
2	Feed / GND	1.5 x 2.75 mm

Antenna is symmetrical. Either of terminals 1 or 2 can be Feed / GND

W3022 1.88-1.93 GHz DECT Antenna PWB Layout Specifications

Ground cleared under antenna, clearance area **10.80 x 6.25 mm**

Matching and tuning component values depend on application and surrounding mechanics / materials.

Feed line should be designed to match 50 Ω characteristic impedance, depending on PWB material and thickness.

Recommended test board layout for electrical characteristic measurement, test board outline size 80 x 37 mm.

PWB layout for W3022 1.88-1.93 GHz DECT Antenna

Note: All dimensions are in metric system.

Matching Component (optional shunt)

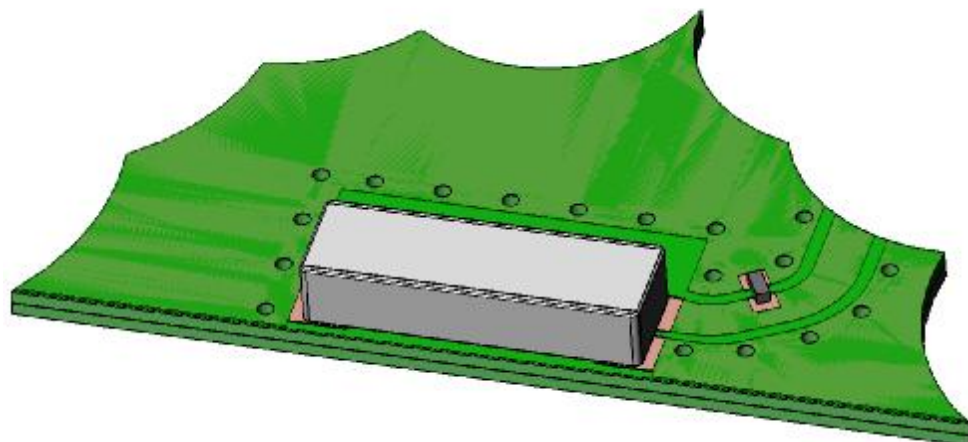
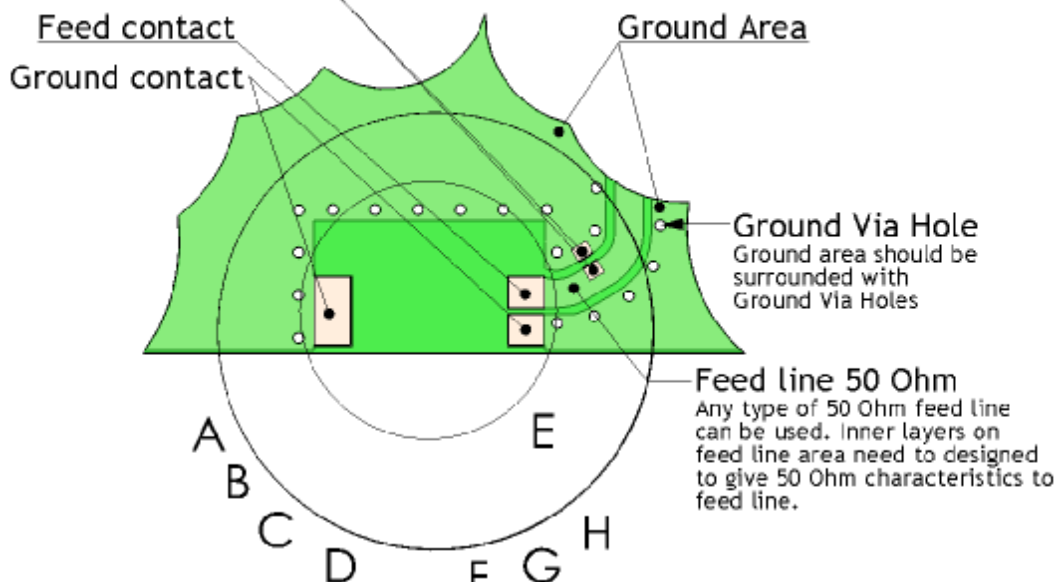

Ground clearance area for W3022 1.88-1.93 GHz DECT Antenna

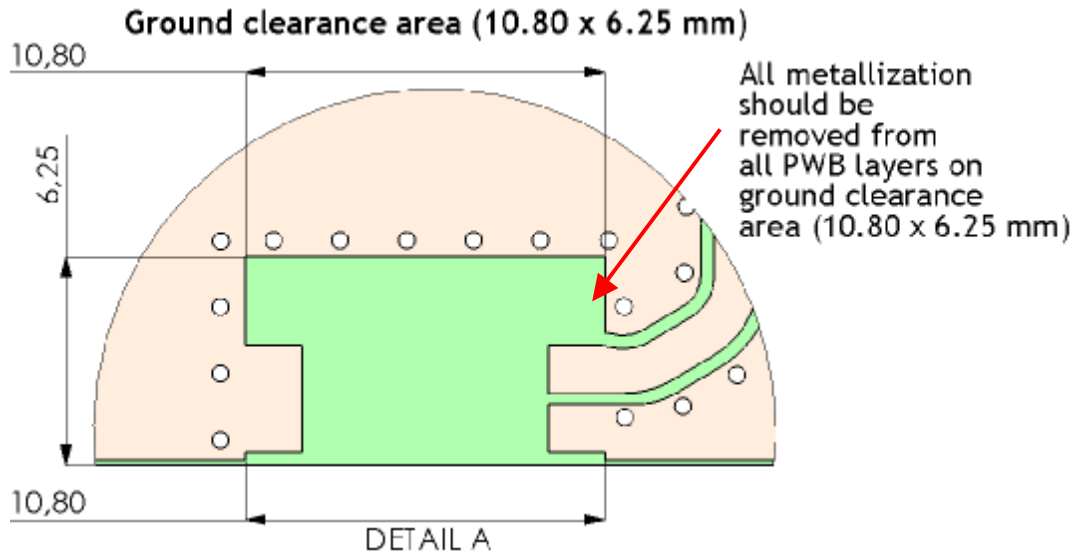

Opening in bottom/inner ground layers

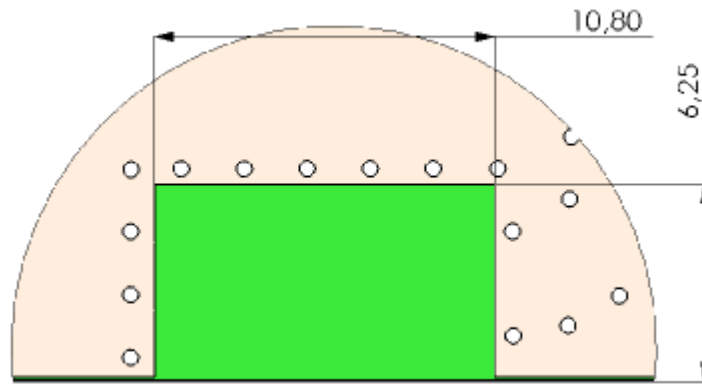

Opening in other layers (no ground/ RF)

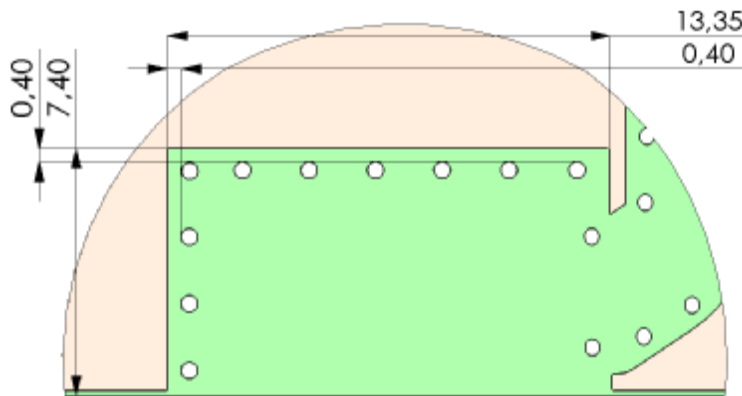

PWB pad dimensions and antenna position for W3022 1.88-1.93 GHz DECT Antenna

Pad dimensions in top copper

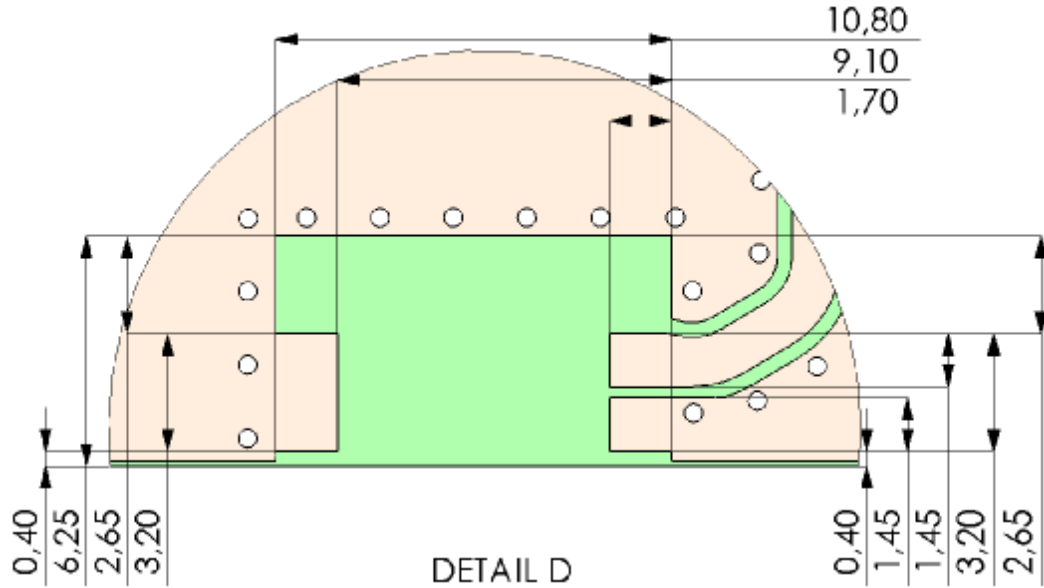

Antenna position on PWB layout

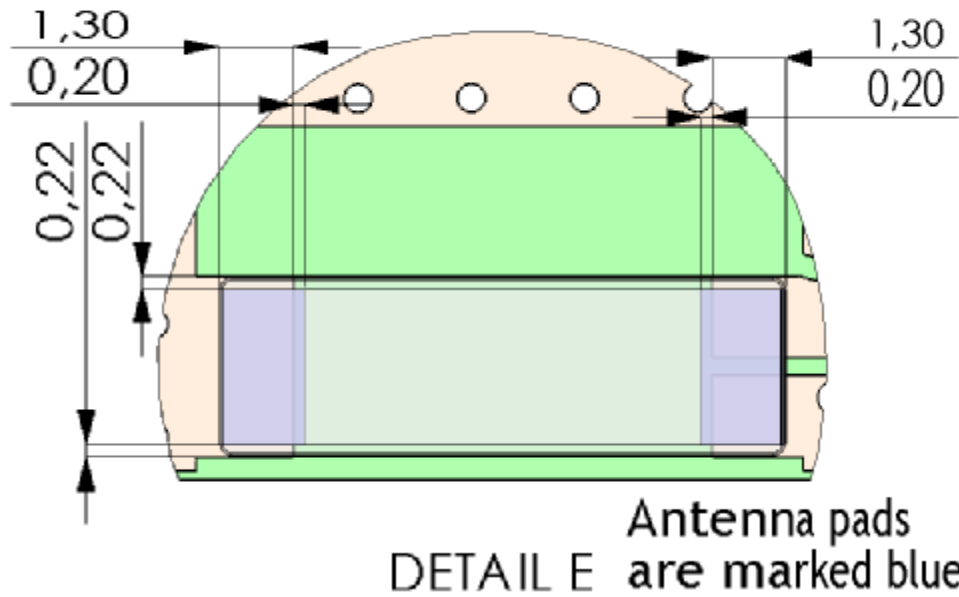

Typical ground via hole placement in PWB layout for W3022 1.88-1.93 GHz DECT Antenna

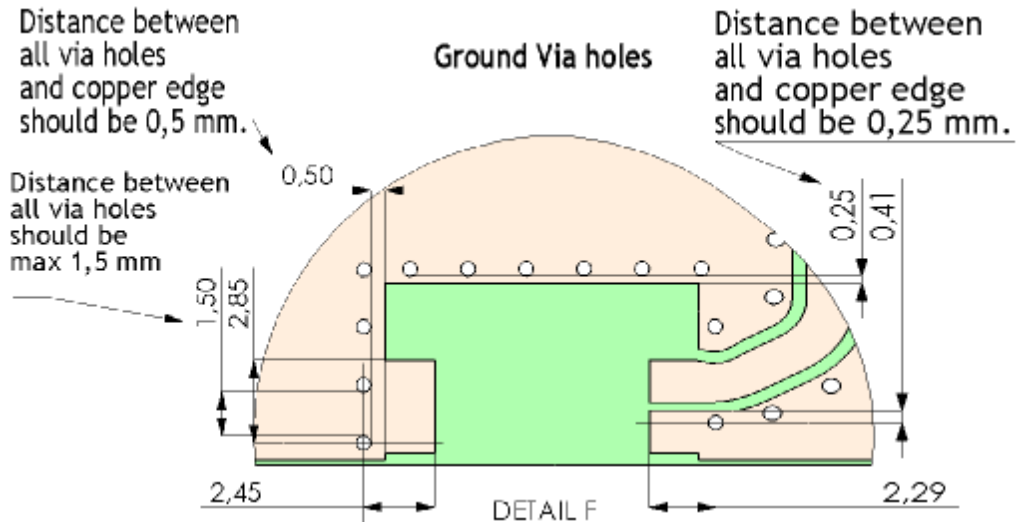

Solder resist opening and Paste stencil recommendation for W3022 1.88-1.93 GHz DECT Antenna **Solder resist opening**

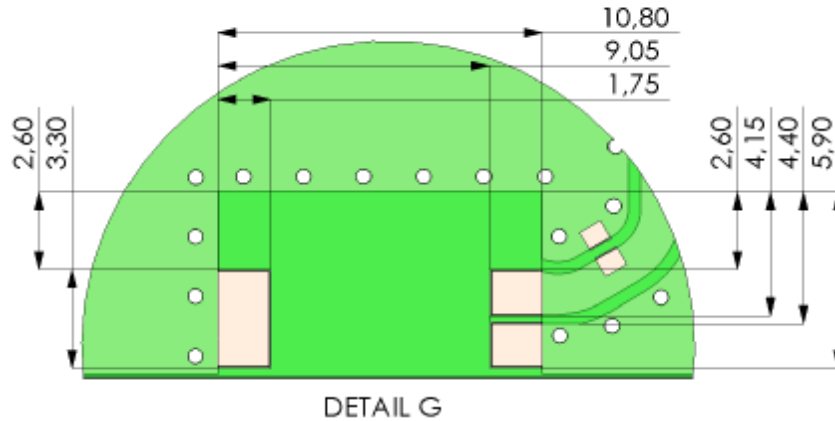

Paste stencil recommendation

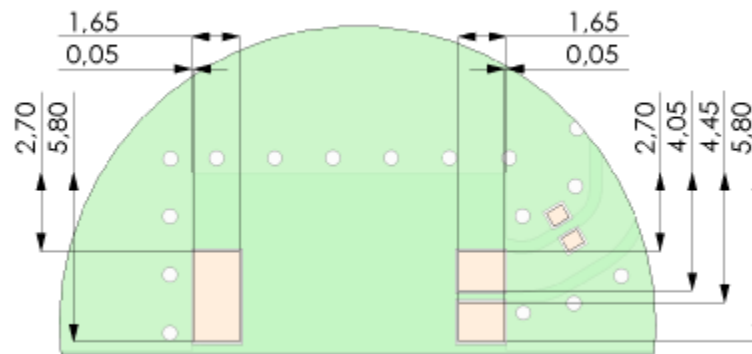

DETAIL H **Paste stencil thickness recommendation is 0,1 mm**

Recommended antenna position on PWB for W3022 1.88-1.93 GHz DECT Antenna

Our test PWB size is 37 x 80 mm, other sized boards can be used depending on customer device size (minimum 35 x 35 mm)

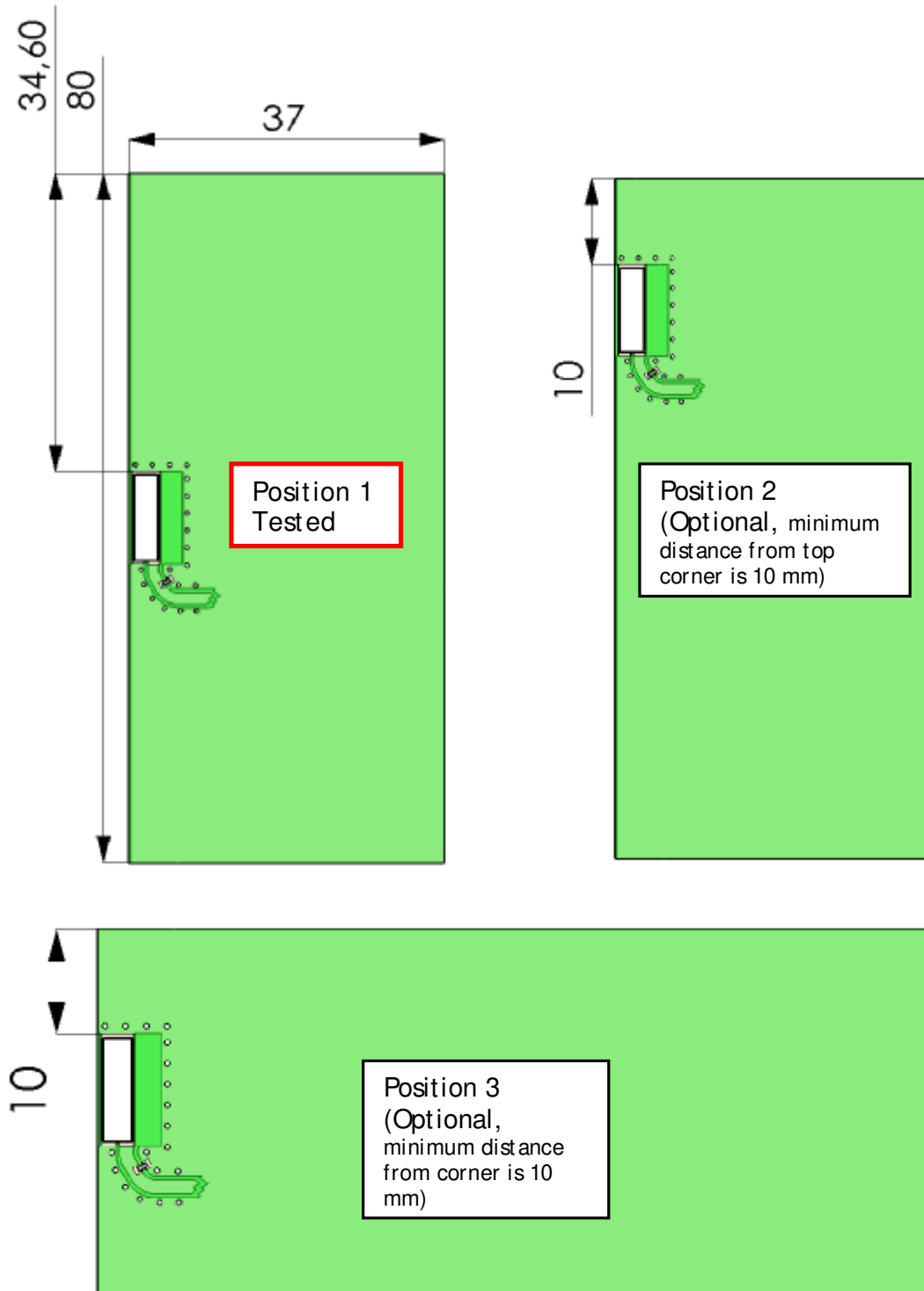

W3022 1.88-1.93 GHz DECT Antenna Test Set Up and Measurement Performance

Ground cleared under antenna, clearance area 10.80 x 6.25 m m

Typical Electrical Characteristics (T=25°C)

Measured on the 80 x 37 mm test board with matching circuit (2,7 pF shunt matching capacitor on feed). Measured in antenna position 1 on PWB layout, see page 9.

Typical Return Loss S11/ impedance, free space efficiency and gain

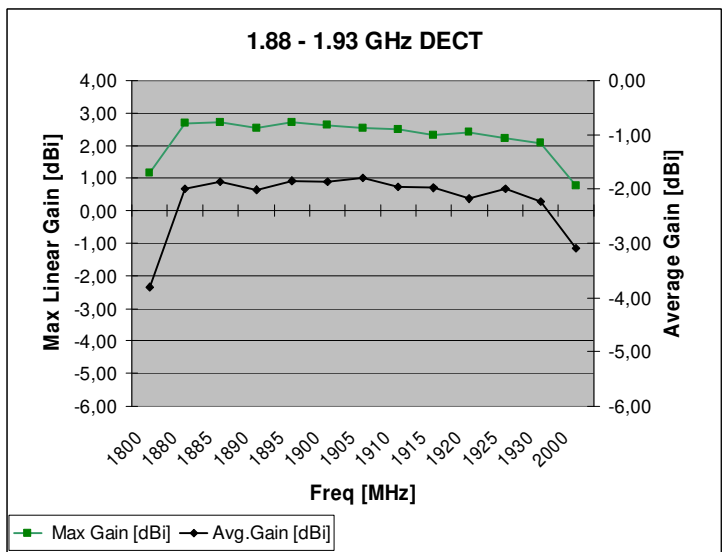
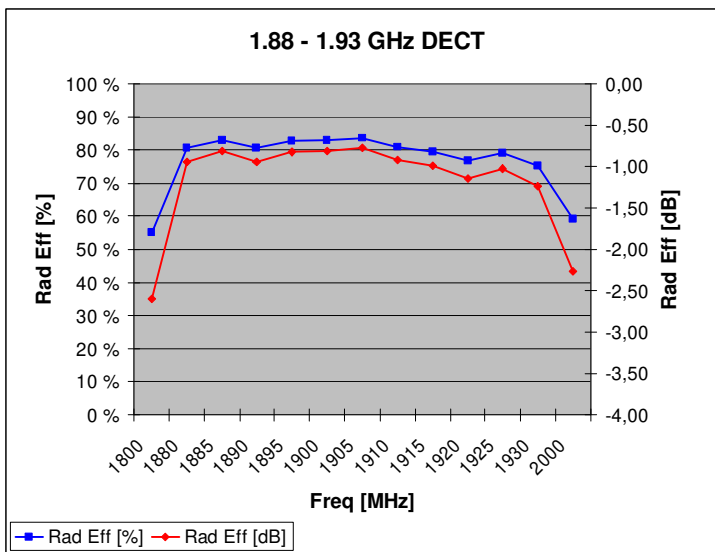
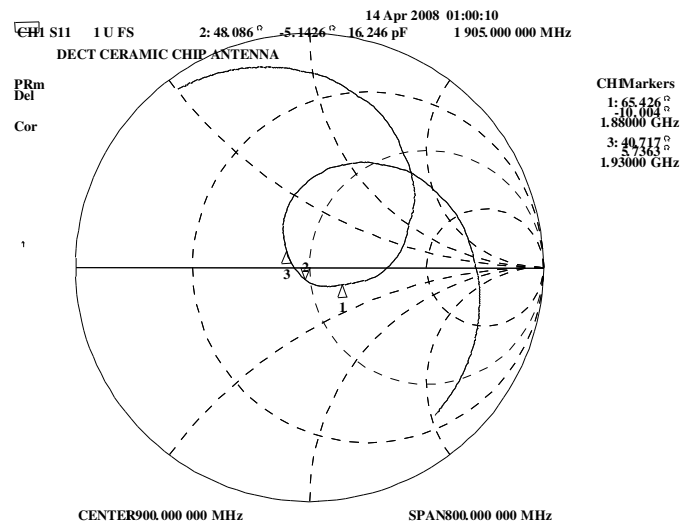
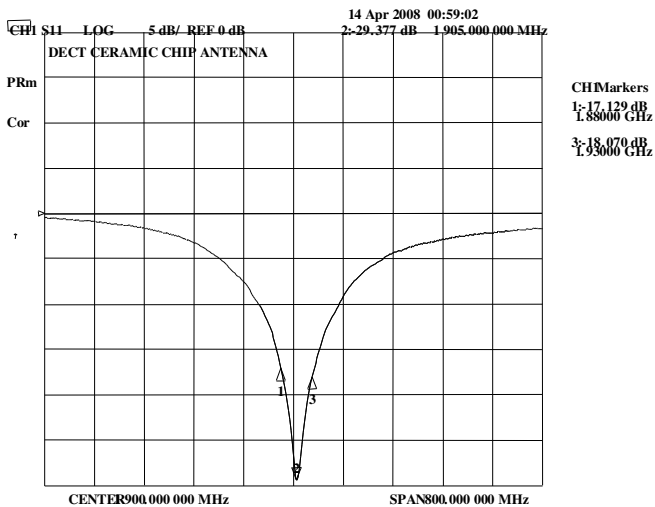

Typical Free Space Radiation Patterns

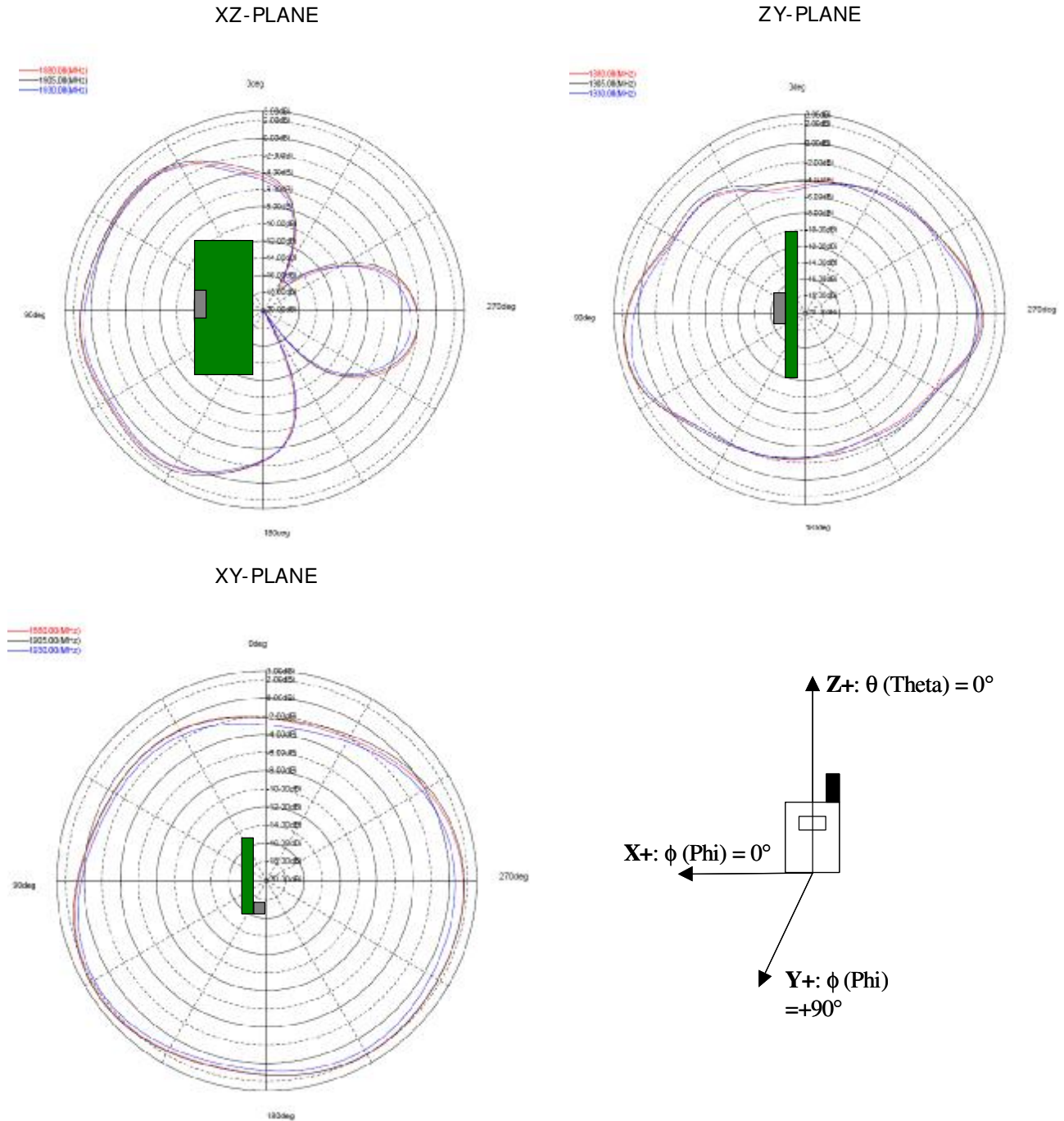

W3022 1.88-1.93 GHz DECT Antenna Packing

General

Tape and reel packing is used. Carrier tape, reel and box dimensions are presented in following pictures.

Carrier tape

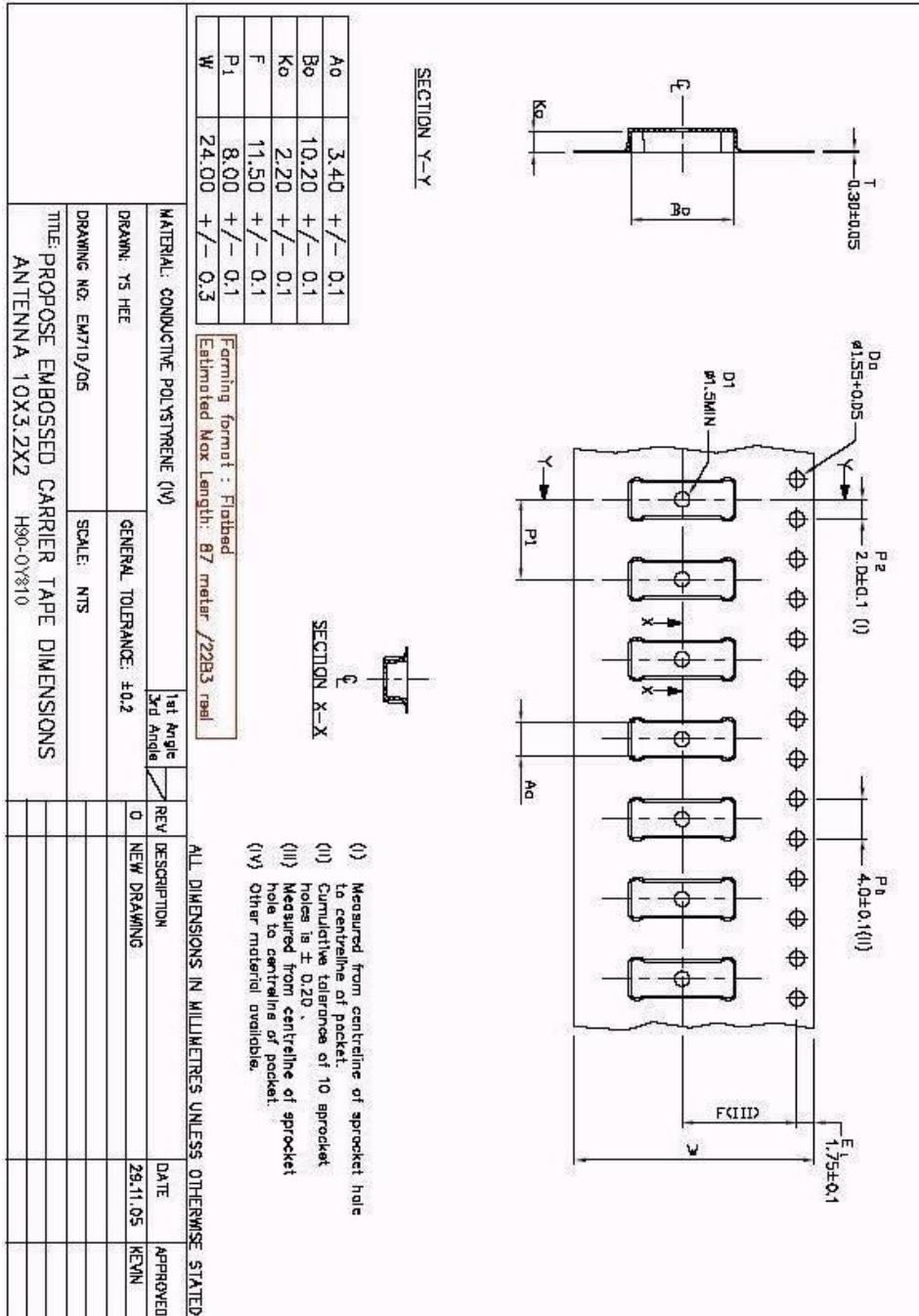

Block orientation

Antenna soldering pads facing down to the bottom of the carrier tape.

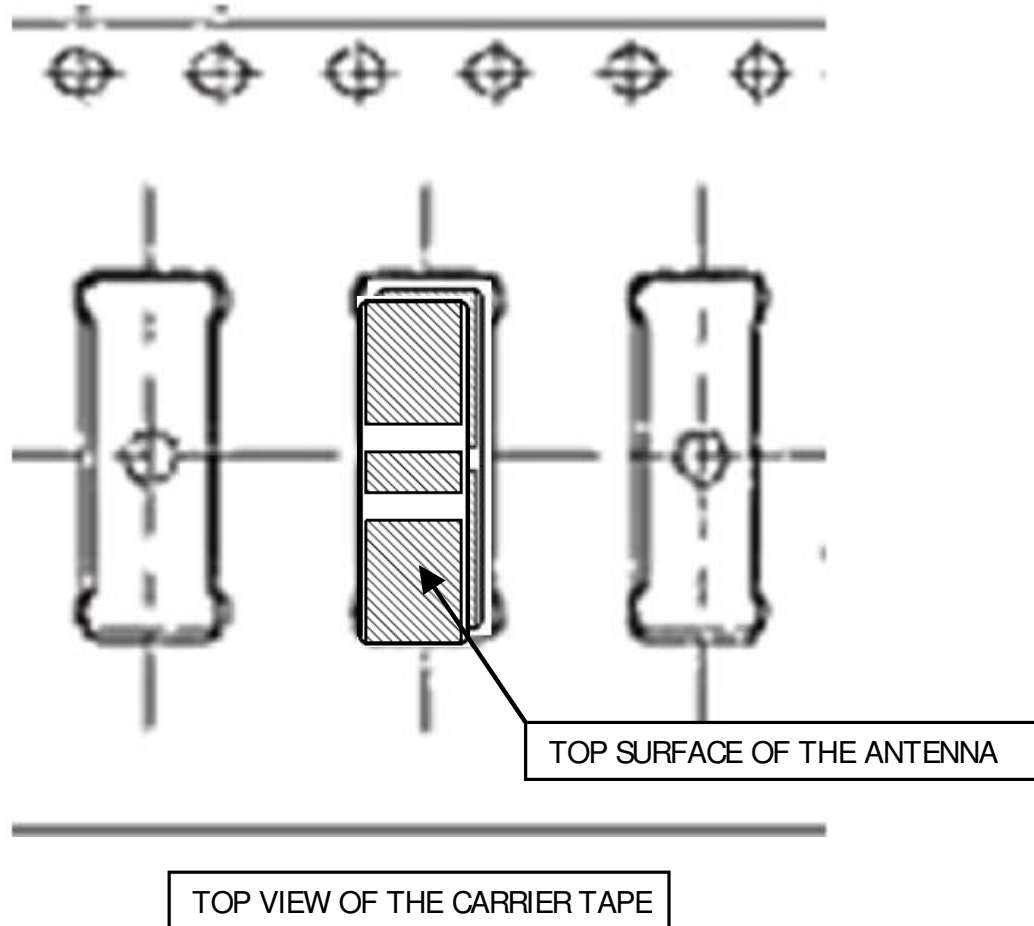

Packing form

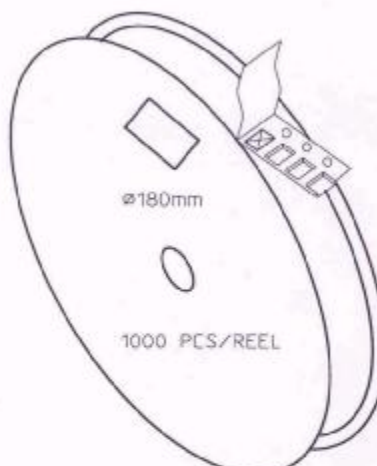
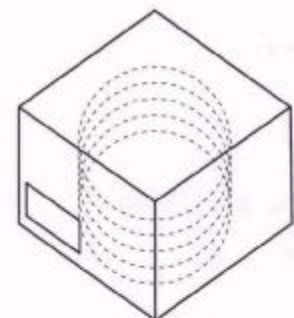
CARRIER TAPE H85-00188
width=24,00 depth=2.20
COVER TAPE H85-00159
width=21.20

LENGTH OF TAPE:

- Leader section: min 350 mm before component section
- Trailer section: min 40 mm after component section.

Empty part cavities at leader and trailer section of the tape must be sealed with top cover tape.

BOX H85-00128 (182x182x125)	1 pcs
- LABEL	1 pcs/BOX
REEL H85-00160 (D180, W28)	4 pcs
- REEL LABEL	1 pcs/REEL

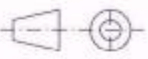
MATERIAL					
HANDLINGS					
		RATIO	DRWN	160107 PeHa	H
			DGNER		G
			CHKD		F
			APPRD		E
PRODUCT			APPRD BY		D
H90-OY810					C
					B
					A
DENOMINATION			VERSION		MOD/DATE/NAME
PACKING FORM					

W3022 1.88-1.93 GHz DECT Antenna

Mechanical Outline

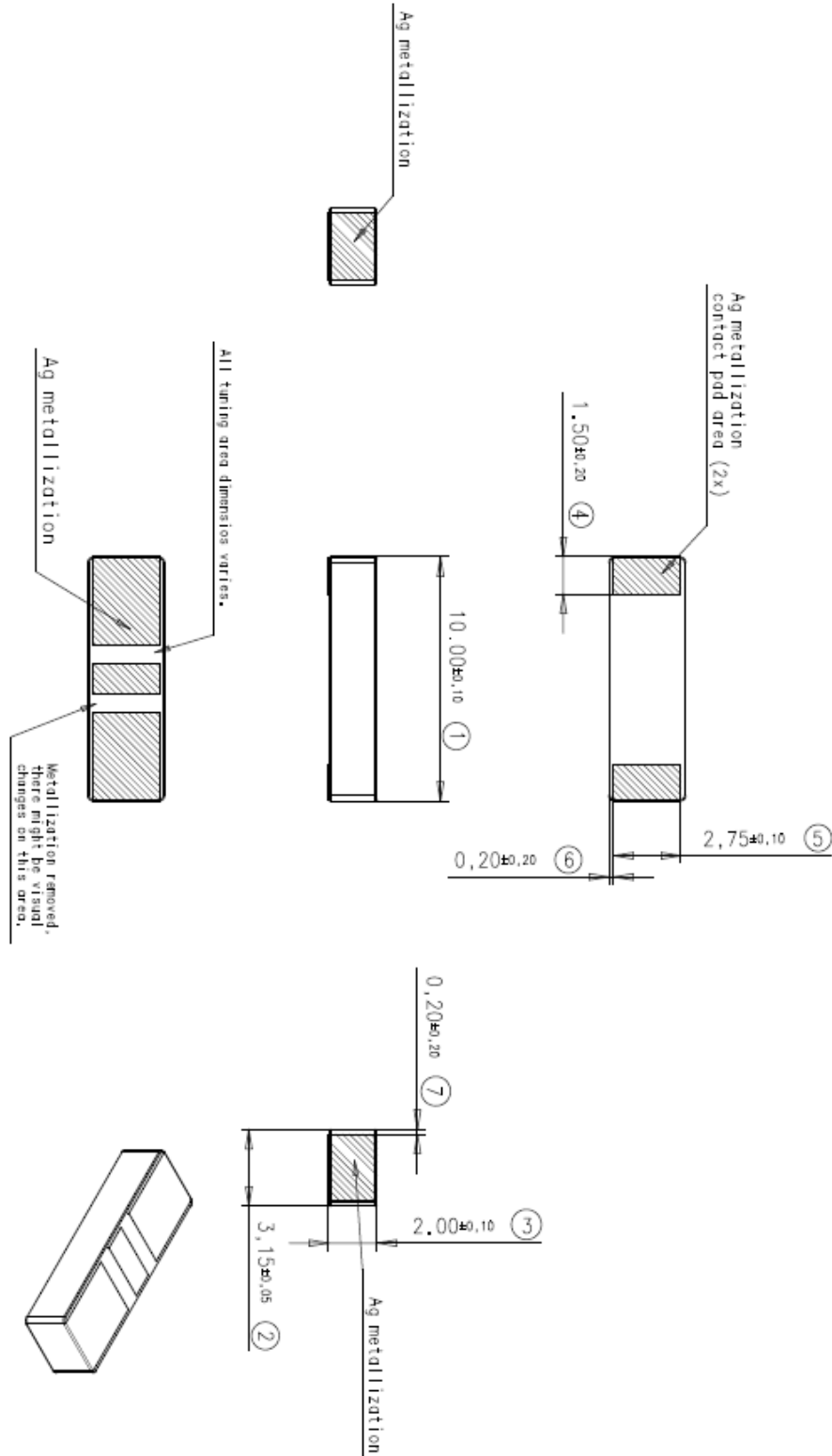

Contact information

For More Information, please contact:

Pulse Finland Oy
Takatie 6
Fin-90440 Kempele
Finland
Tel. +358 207 935 500
Fax +358 207 935 501 (sales)

Domicile: Kempele
Business ID: 1933992-8
firstname.lastname@pulseeng.com
www.pulseeng.com/antennas

Pulse World Wide Headquarters
12220 World Trade Drive
San Diego, CA 92128
U.S.A

Tel. +1 858 674 8100
Fax +1 858 674 826
www.pulseeng.com

This is a "Preliminary" product application notes. Products mentioned on this application notes are in development and in the process of being qualified. These products are not fully released nor are they in production. Features, specifications and performance of products offered are subject to change without notice. Other brand and product names mentioned herein may be products and/or registered trademarks of their respective ones. For current info on this product, please contact the Pulse San Diego office.

© Copyright, 2006. Pulse Finland Oy. All rights reserved.