

THIS DRAWING IS UNPUBLISHED. RELEASED FOR PUBLICATION .19
 © COPYRIGHT 19 BY AMP INCORPORATED. ALL INTERNATIONAL RIGHTS RESERVED.

MOD	LOC	DIST	P	F	ZONE	LTR	REVISIONS	DATE	APPD
8	BD	39				C	REDRAWN ON CAD	4-12-90	-

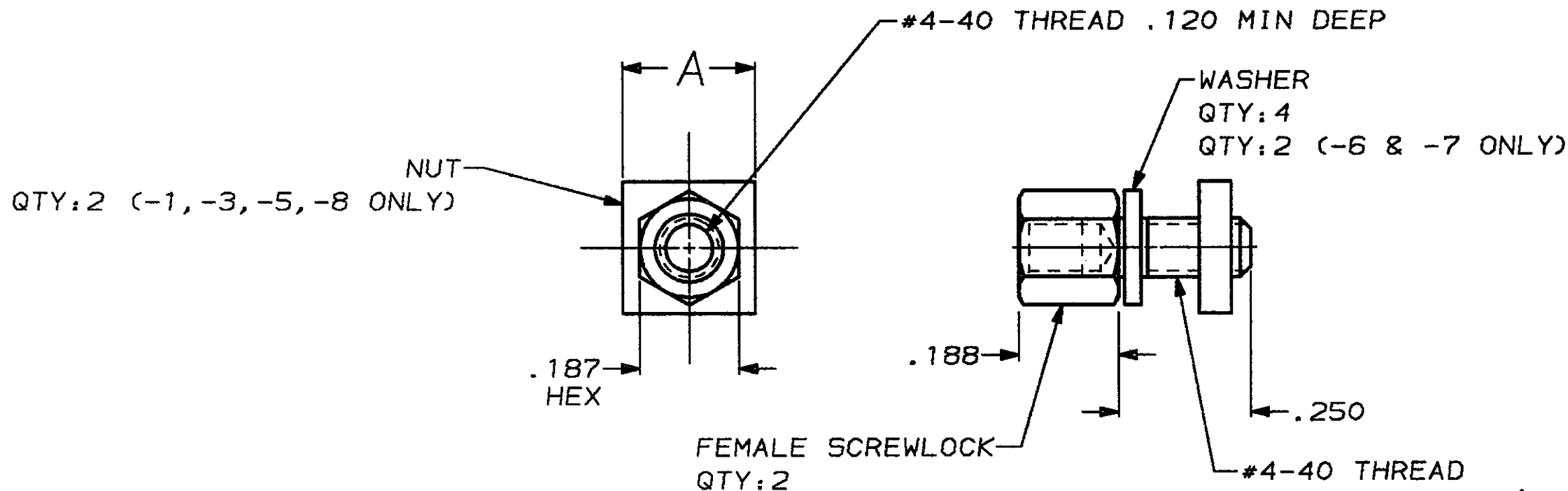

OBSOLETE	5	.250	2	207952-8
OBSOLETE	5	-	1	207952-7
OBSOLETE	4	-	1	207952-6
OBSOLETE	5	.250	1	207952-5
OBSOLETE	4	.350	2	207952-4
	4	.250	2	207952-3
OBSOLETE	4	.350	1	207952-2
	4	.250	1	207952-1
		PACKAGING	A	FINISH
				PART NUMBER

- 1 ZINC PLATED PER ASTM B633, TYPE II, CLASS SCI, YELLOW CHROMATE.
- 2 ZINC PLATED PER ASTM B633, TYPE III, CLASS SCI, CLEAR CHROMATE.
- 3. PARTS PACKAGED UNASSEMBLED.
- 4 PARTS PACKAGED AS A UNIT KIT.
- 5 PARTS INDIVIDUALLY BULK PACKED & SHIPPED AS A UNIT PACKAGE.

DO NOT SCALE PRINT. UNLESS SPECIFIED DIMENSIONS IN INCHES. TOLERANCES ON: 2 PLC DEC ± - 3 PLC DEC ± .005 ANGLES ± -		DR 4-12-90 J. GALLUCCI BG CHK 6-15-90 W. G. [Signature] APPD [Signature] 7-11-90 APPD [Signature] 7-16-90 PRODUCT SPEC	AMP INCORPORATED Harrisburg, Pa. 17105	
MATERIAL STEEL PER ASTM A108	FINISH SEE TABLE	APPLICATION SPEC -	NAME SCREWLOCK KIT, FEMALE, SHORT, AMPLIMITE™ HDP-20	
		WEIGHT -	SIZE B	FSC# NO 00779
			SCALE 4:1	DRAWING NO 207952
				SHEET 1 OF 1