



Single Port RJ45 Connector

AR11-4394I



- 10/100 Base T for LAN, WAN and other Ethernet applications
- Meets IEEE 802.3 specification
- Industrial Operating Temp: -40°C +85°C

Electrical Specifications @ 25°C

OCL(μH Min) @100KHz, 0.1V With 8mA DC Bias	Turns Ratio (±3%)		DCR (Ω) Max	Return Loss (dB Min)		
	TX=1CT:1CT	RX=1CT:1CT		1-30MHz	30-60MHz	60-100MHz
350	1:1	1:1	1.2	-18	-15	-12

Electrical Specifications @ 25°C

Cross Talk (dB Min)			Insertion Loss (dB Max)	CMR (dB Min)		Hi-Pot
30MHz	60MHz	100MHz	1-100MHz	1-50MHz	50-150MHz	
-40	-35	-30	-1.0	-30	-20	1500Vrms

All specifications subject to change without notice.

MECHANICAL

Dimensions: $\frac{\text{inch}}{\text{mm}}$

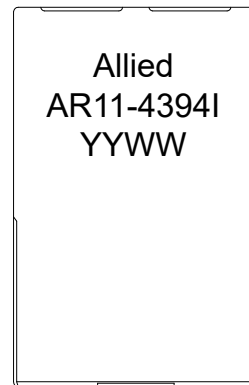
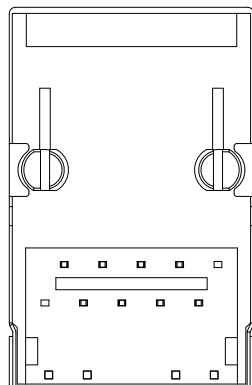
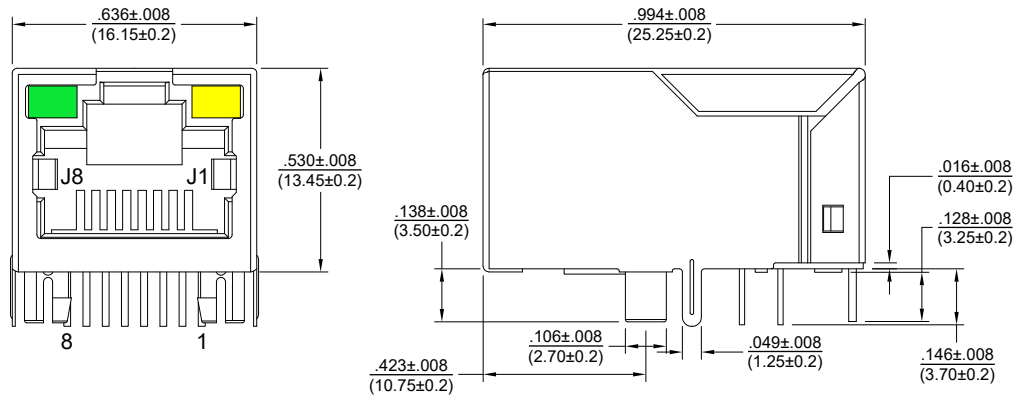



SCHEMATIC

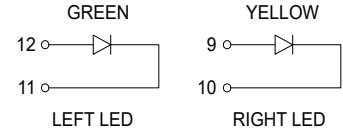
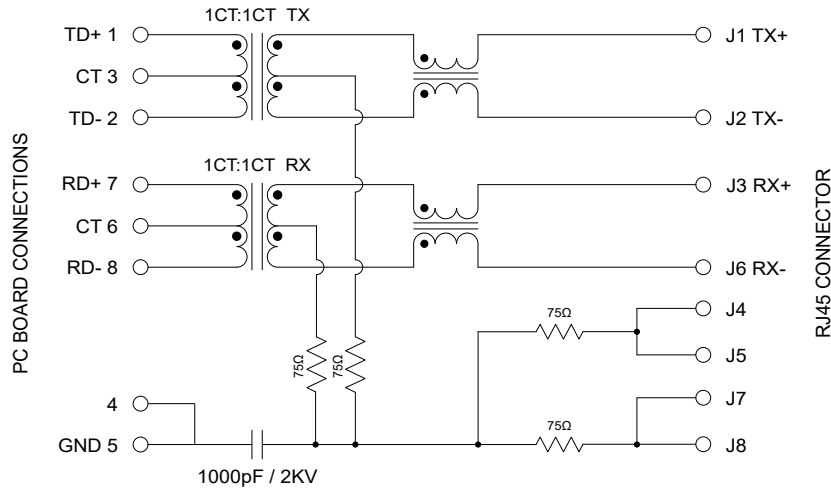

Emitting Color	λ_p (nm)	$V_F@I_F=20mA$	$I_R@V_R=5V$
Green	570	1.8~2.4V	10 μ A Max
Yellow	590	1.8~2.4V	10 μ A Max

PCB LAYOUT

Dimensions: mm

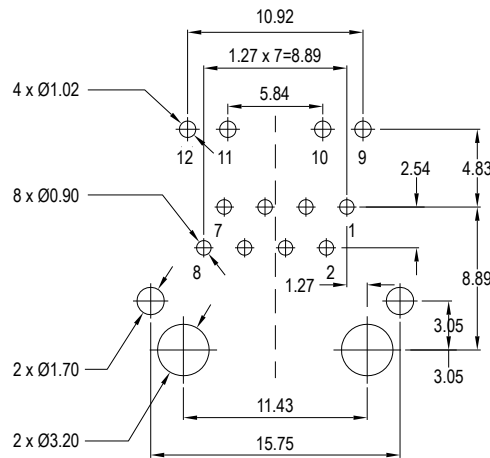

Tolerance is $\pm 0.2mm$ unless otherwise specified

NOTES

- Connector Materials:**
Housing: Thermoplastic PBT+30% G.F. UL94V-0
Contact: Phosphor Bronze C5210R-EH Thickness = 0.35mm
Pins: Brass C2680R-H Thickness = 0.35mm
Shield: SUS 201-1/2H Thickness = 0.20mm
Contact Plating: Gold 6 μ " min. in contact area
- Wave solder tip temperature:** 265°C max, 5 sec. max