

1. PREFIX AND SUFFIX NUMBERS MUST MATCH THOSE ON PLUG ASSEMBLY FOR PARTS TO MATE.
2. POLYESTER, FLAME RETARDANT, UL 94V-0 RATED, GLASS FILLED, BLACK.
3. 0.76µm [.000030] MIN BRIGHT TIN OVER 1.27µm [.000050] MIN NICKEL.
4. 1.27µm [.000050] MIN GOLD ON MATING SURFACE FOR A LENGTH OF 2.54 [.100] MIN, 3.81µm [.000150] MIN MATTE TIN ON OPPOSITE END FOR A LENGTH OF 3.81 [.150] MIN, BOTH OVER 1.27µm [.000050] MIN NICKEL ON ENTIRE CONTACT.
5. DIMENSION INDICATES CONTACT MATING AREA.
6. PLATING MEASUREMENT POINT.

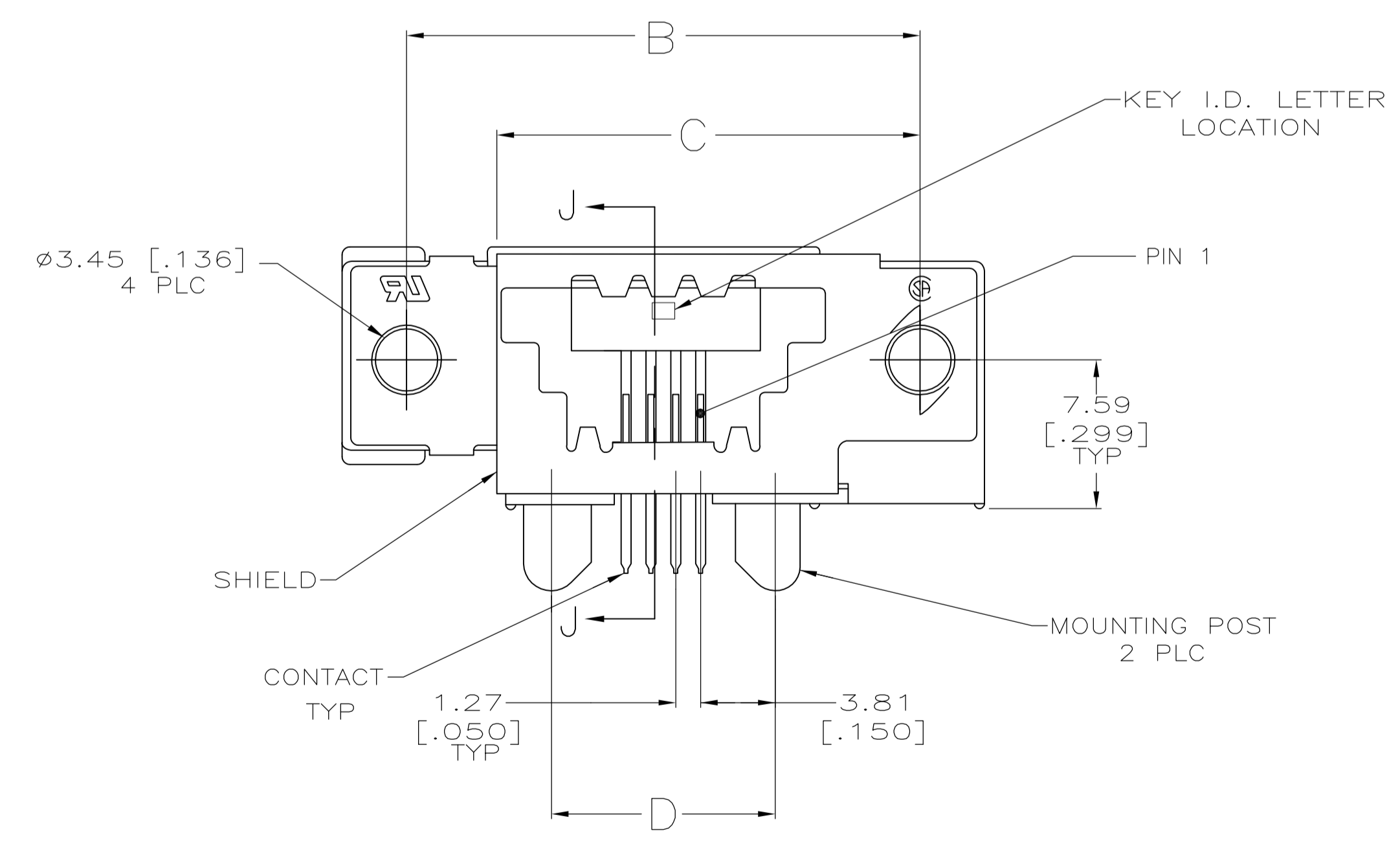
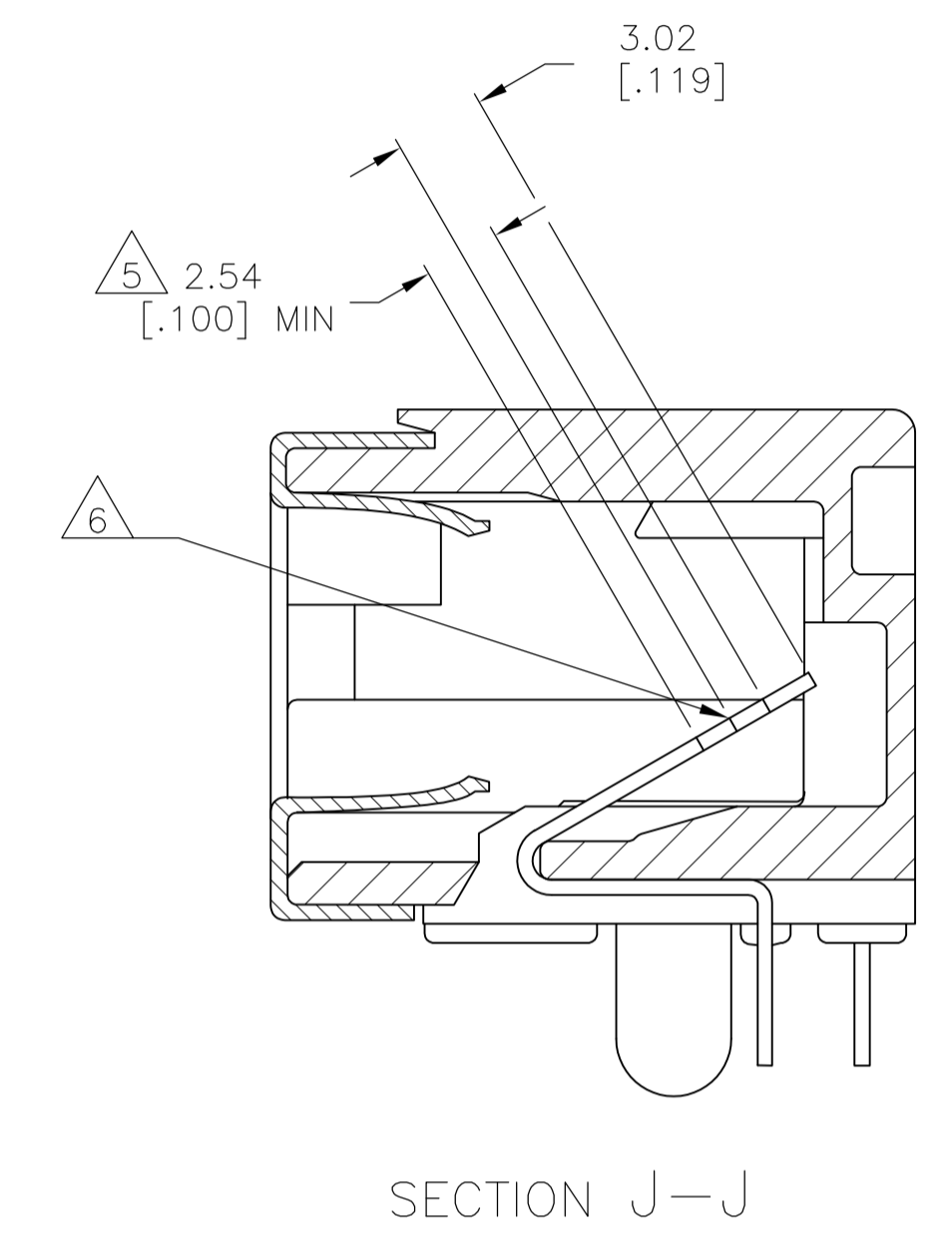
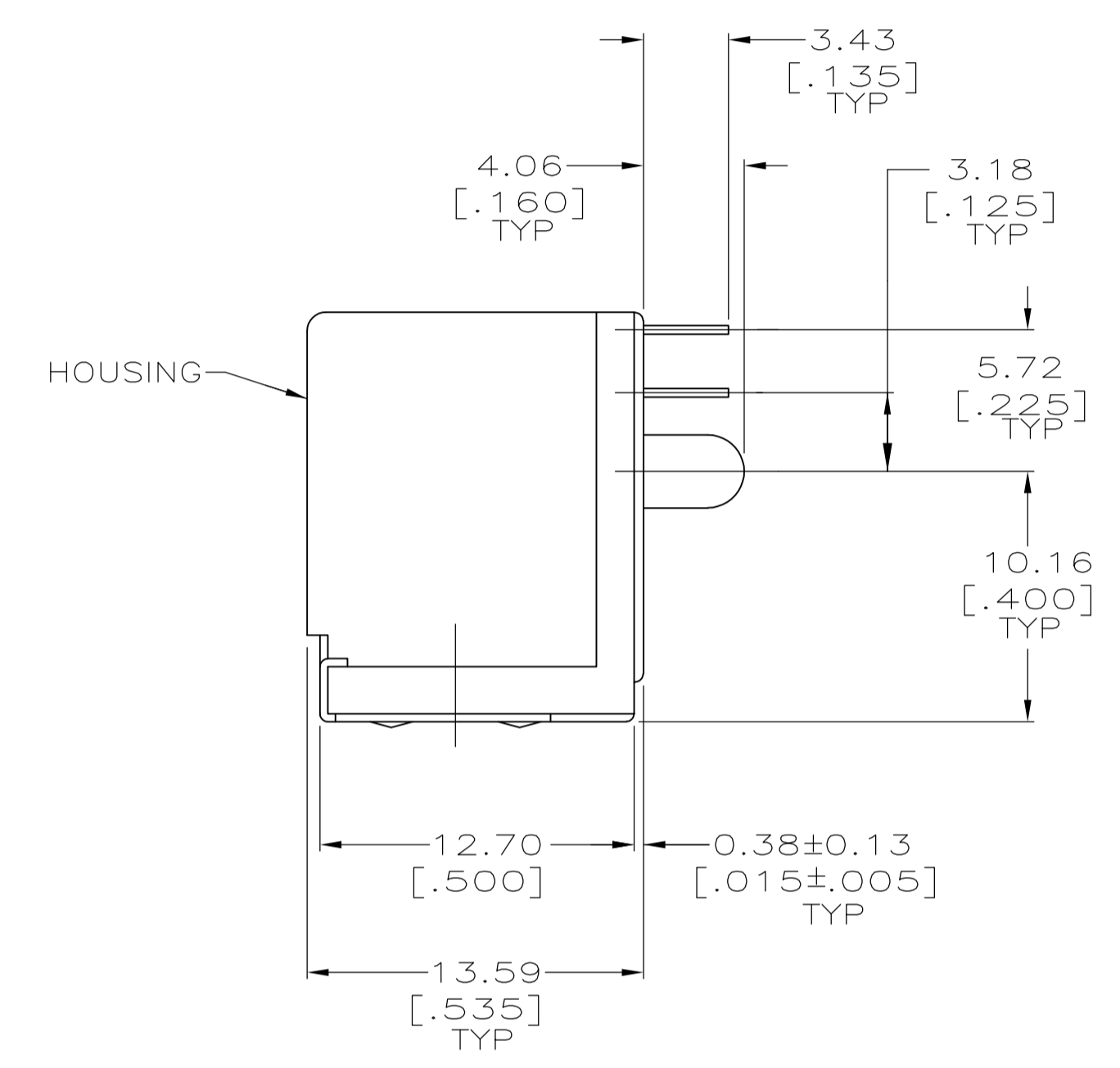
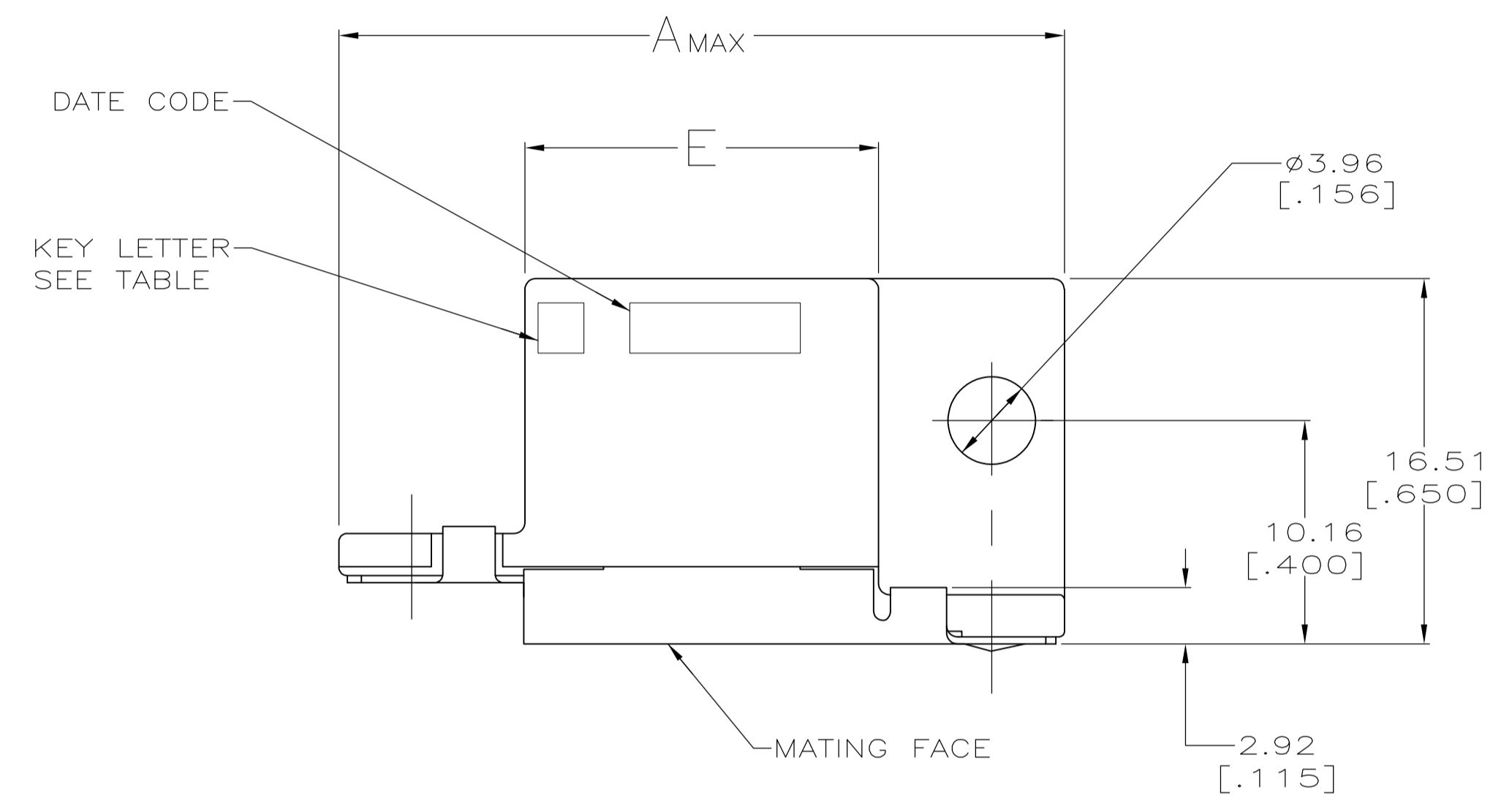

OBSOLETE	16.00 [.630]	11.43 [.450]	21.46 [.845]	26.24 [1.033]	33.02 [1.300]	4	F	6-1761186-1
	31.24 [1.230]	26.44 [1.041]	36.70 [1.445]	41.48 [1.633]	48.26 [1.900]	16	E	5-1761186-6
	21.08 [.830]	16.51 [.650]	26.54 [1.045]	31.32 [1.233]	38.10 [1.500]	8	E	5-1761186-3
OBSOLETE	18.54 [.730]	13.97 [.550]	24.00 [.945]	28.78 [1.133]	35.56 [1.400]	6	E	5-1761186-2
	16.00 [.630]	11.43 [.450]	21.46 [.845]	26.24 [1.033]	33.02 [1.300]	4	E	5-1761186-1
OBSOLETE	18.54 [.730]	13.97 [.550]	24.00 [.945]	28.78 [1.133]	35.56 [1.400]	6	C	3-1761186-2
OBSOLETE	16.00 [.630]	11.43 [.450]	21.46 [.845]	26.24 [1.033]	33.02 [1.300]	4	C	3-1761186-1
OBSOLETE	21.08 [.830]	16.51 [.650]	26.54 [1.045]	31.32 [1.233]	38.10 [1.500]	8	B	2-1761186-3
OBSOLETE	16.00 [.630]	11.43 [.450]	21.46 [.845]	26.24 [1.033]	33.02 [1.300]	4	B	2-1761186-1
OBSOLETE	31.24 [1.230]	26.44 [1.041]	36.70 [1.445]	41.48 [1.633]	48.26 [1.900]	16	A	1-1761186-6
OBSOLETE	18.54 [.730]	13.97 [.550]	24.00 [.945]	28.78 [1.133]	35.56 [1.400]	6	A	1-1761186-2
	16.00 [.630]	11.43 [.450]	21.46 [.845]	26.24 [1.033]	33.02 [1.300]	4	A	1-1761186-1
	E	D	C	B	A	NO OF POSN	KEY I.D. LETTER	PART NO

THIS DRAWING IS A CONTROLLED DOCUMENT.

DIMENSIONS: mm [INCHES]	TOLERANCES UNLESS OTHERWISE SPECIFIED:	DIN B MCMASER 26APR04	APPRO C ROHDE 26APR04	NAME M. WALMSLEY 26APR04	PRODUCT SPEC 108-2047	APPLICATION SPEC 114-2081	SIZE A1	CAGE CODE 00779	DRAWING NO C=1761186	RESTRICTED TO
	0 PLC ± -									
	1 PLC ± -									
	2 PLC ± -									
	3 PLC ± 0.38 [.015]									
	4 PLC ± -									
	ANGLES ± -									
MATERIAL	FINISH	WEIGHT								

CUSTOMER DRAWING SCALE 4:1 SHEET 1 OF 1 REV B