



ON Semiconductor®

FSA2270T Low-Voltage, Dual-SPDT (0.4 Ω) Analog Switch with Negative Swing Audio Capability

Features

- 0.4 Ω Typical On Resistance (R_{ON}) for +3.0 V Supply
- 0.25 Ω Maximum R_{ON} Flatness for +3.0 V Supply
- -3 db Bandwidth: > 50 MHz
- Low I_{CC} Current Over Expanded Control Input Range
- Packaged in 10-Lead UMLP
- Power-Off Protection on Common Ports
- Broad V_{CC} Operating Range: 1.65 to 4.3 V
- Noise Immunity Termination Resistors
- Low Electrostatic Discharge (ESD)
 - Human Body Model (JEDEC: JESD22-A114)
 - Power to GND 16 kV
 - I/O to GND 11 kV
 - All other pins 8 kV
 - Charged Device Model (JEDEC: JESD22-A101)

Applications

- Cell Phone, PDA, Digital Camera, and Notebook
- LCD Monitor, TV, and Set-Top Box

Description

The FSA2270T is a high-performance, dual Single-Pole Double-Throw (SPDT) analog switch with negative swing audio capability. The FSA2270T features ultra-low R_{ON} of 0.4 Ω (typical) at 3.0 V V_{CC} . The FSA2270T operates over a wide V_{CC} range of 1.65 V to 4.3 V, is fabricated with sub-micron CMOS technology to achieve fast switching speeds, and is designed for break-before-make operation. The select input is TTL-level compatible.

The FSA2270T features very low quiescent current even when the control voltage is lower than the V_{CC} supply. This feature suits mobile handset applications by allowing direct interface with baseband processor general-purpose I/Os with minimal battery consumption.

The FSA2270T includes termination resistors that improve noise immunity during overshoot excursions, off-isolation coupling, or “pop-minimization.”

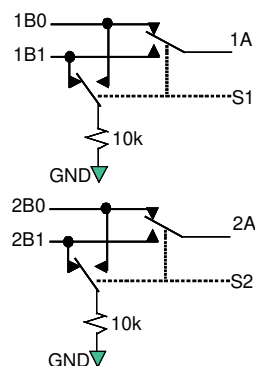

Figure 1. Analog Symbol

Ordering Information

Part Number	Top Mark	Package Description
FSA2270TUMX	HK	10-Lead, Quad Ultrathin Molded Leadless Package (UMLP), 1.4 x 1.8 mm, 0.4 mm Pitch

Pin Configuration

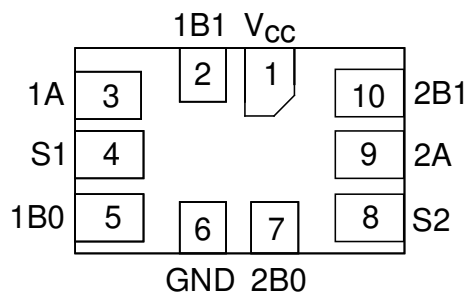

Figure 2. 10-Pin UMLP (Top Through View)

Pin Descriptions

Pin#	Name	Description
1	V _{CC}	Supply Voltage
3, 9	1A, 2A	Data Points
4, 8	S1, S2	Switch Select Pins
5, 7	1B0, 2B0	Data Ports
6	GND	Ground
2, 10	1B1, 2B1	Data Ports

Truth Table

Control Input, S _n	Function
LOW Logic Level	nB0 connected to nA; nB1 terminated to GND
HIGH Logic Level	nB1 connected to nA; nB0 terminated to GND

Absolute Maximum Ratings

Stresses exceeding the absolute maximum ratings may damage the device. Functional operation above the recommended operating conditions is not implied. In addition, extended exposure to stresses above the recommended operating conditions may affect device reliability. Absolute maximum ratings are stress ratings only.

Symbol	Parameter	Min.	Max.	Units	
V _{CC}	Supply Voltage	-0.5	5.5	V	
V _{SW}	Switch I/O Voltage ⁽¹⁾	1B0, 1B1, 2B0, 2B1, 1A, 2A Pins	V _{CC} - 4.3	V _{CC} + 0.3	V
V _{CNTRL}	Control Input Voltage ⁽¹⁾	S1, S2	-0.5	V _{CC} + 0.3	
I _{IK}	Input Clamp Diode Current		-50	mA	
I _{SW}	Switch I/O Current (Continuous)		350	mA	
I _{SWPEAK}	Peak Switch Current (Pulsed at 1 ms Duration, <10% Duty Cycle)		500	mA	
T _{STG}	Storage Temperature Range	-65	+150	°C	
T _J	Maximum Junction Temperature		+150	°C	
T _L	Lead Temperature Soldering, 10 Seconds		+260	°C	
ESD	Human Body Model, JEDEC: JESD22-A114	Power to GND		16	kV
		I/O to GND		11	kV
		All Other Pins		8	kV
	Charged Device Model, JEDEC: JESD22-C101			2	kV

Note:

- Input and output negative ratings may be exceeded if input and output diode current ratings are observed.

Recommended Operating Conditions

The Recommended Operating Conditions table defines the conditions for actual device operation. Recommended operating conditions are specified to ensure optimal performance to the datasheet specifications. ON Semiconductor does not recommend exceeding them or designing to absolute maximum ratings.

Symbol	Parameter	Min.	Max.	Units
V _{CC}	Supply Voltage	1.65	4.30	V
V _{S1, S2}	Control Input Voltage	0	V _{CC}	V
V _{SW}	Switch I/O Voltage	V _{CC} - 4.3	V _{CC}	V
T _A	Operating Temperature	-40	+85	°C

DC Electrical Characteristics

All typical values are for $V_{CC}=3.3\text{ V}$ at $T_A=25^\circ\text{C}$ unless otherwise specified.

Symbol	Parameter	Conditions	V_{CC} (V)	$T_A=+25^\circ\text{C}$			$T_A=-40$ to $+85^\circ\text{C}$		Units
				Min.	Typ.	Max.	Min.	Max.	
V_{IH}	Input Voltage High		3.60 to 4.30				1.7		V
			2.70 to 3.60				1.5		
			2.30 to 2.70				1.4		
			1.65 to 1.95				0.9		
V_{IL}	Input Voltage Low		3.60 to 4.30					0.7	V
			2.70 to 3.60					0.5	
			2.30 to 2.70					0.4	V
			1.65 to 1.95					0.4	
I_{IN}	Control Input Leakage (S1, S2)	$V_{IN}=0$ to V_{CC}	1.65 to 4.30				-0.5	0.5	μA
$I_{A(ON)}$	On Leakage Current of Port nA	$nA=0.5\text{ V}$, $V_{CC}=0.5\text{ V}$ nB0 or $nB1=V_{CC}-0.5\text{ V}$, 0.5 V , or Floating Figure 5	1.95 to 4.30				-1	1	μA
I_{OFF}	Power-Off Leakage Current (Common Port Only 1A, 2A)	Common Port (1A, 2A), $V_{IN}=0\text{ V}$ to 4.3 V , $V_{CC}=0\text{ V}$ nB0, nB1=0 V or Floating	0				-45	45	μA
R_{ON}	Switch On Resistance ^(2,5)	$I_{ON}=100\text{ mA}$, nB0 or nB1=0.7 V, 3.6 V, 4.3 V Figure 3	4.30		0.30				Ω
		$I_{ON}=100\text{ mA}$, nB0 or nB1=0.7 V, 3.6 V, 4.3 V Figure 3	3.00		0.40			0.80	
		$I_{ON}=100\text{ mA}$, nB0 or nB1=0 V, 0.7 V, 1.6 V, 2.3 V Figure 3	2.30		0.52				
		$I_{ON}=100\text{ mA}$, nB0 or nB1=0 V, 0.7 V, 1.65 V Figure 3	1.65		1.00				
ΔR_{ON}	On Resistance Matching Between Channels ⁽³⁾	$I_{ON}=100\text{ mA}$, nB0 or nB1=0.7 V	4.30		0.04			0.13	Ω
			3.00		0.06			0.13	
			2.30		0.12				
			1.65		1.00				
$R_{FLAT(ON)}$	On Resistance Flatness ⁽⁴⁾	$I_{OUT}=100\text{ mA}$, nB0 or nB1=0 V to V_{CC}	4.30					0.25	Ω
			3.00					0.25	
			2.30		0.5				
			1.65		0.6				
R_{TERM}	Internal Termination Resistors ⁽⁵⁾				10			$\text{k}\Omega$	
I_{CC}	Quiescent Supply Current	$V_{IN}=0\text{ V}$ or V_{CC} , $I_{OUT}=0\text{ mA}$	4.30	-100		100	-500	500	nA
I_{CCT}	Increase in I_{CC} per Input	Input at 2.6 V	4.30		3.0			10.0	μA
		Input at 1.8 V			7.0			15.0	

Notes:

- On resistance is determined by the voltage drop between A and B pins at the indicated current through the switch.
- $\Delta R_{ON}=R_{ONmax} - R_{ONmin}$ measured at identical V_{CC} , temperature, and voltage.
- Flatness is defined as the difference between the maximum and minimum value of on resistance (R_{ON}) over the specified range of conditions.
- Guaranteed by characterization, not production tested.

AC Electrical Characteristics

All typical value are for $V_{CC}=3.3$ V at $T_A=25^\circ\text{C}$ unless otherwise specified.

Symbol	Parameter	Conditions	V_{CC} (V)	$T_A=+25^\circ\text{C}$			$T_A=-40$ to $+85^\circ\text{C}$		Units	Figure
				Min.	Typ.	Max.	Min.	Max.		
t_{ON}	Turn-On Time	nB0 or nB1=1.5 V, $R_L=50\ \Omega$, $C_L=35\ \text{pF}$	3.60 to 4.30			60	15	65	ns	Figure 6 Figure 7
			2.70 to 3.60			65	15	70		
			2.30 to 2.70			80	15	85		
			1.65 to 1.95		100					
t_{OFF}	Turn-Off Time	nB0 or nB1=1.5 V, $R_L=50\ \Omega$, $C_L=35\ \text{pF}$	3.60 to 4.30			55	5	60	ns	Figure 6 Figure 7
			2.70 to 3.60			60	5	65		
			2.30 to 2.70			65	5	70		
			1.65 to 1.95		65					
t_{BBM}	Break-Before-Make Time	nB0 or nB1=1.5 V, $R_L=50\ \Omega$, $C_L=35\ \text{pF}$	3.60 to 4.30		3		1		ns	Figure 8
			2.70 to 3.60		5		2			
			2.30 to 2.70		10		2			
			1.65 to 1.95		15		2			
Q	Charge Injection	$C_L=1.0\ \text{nF}$, $V_S=0\ \text{V}$, $R_S=0\ \Omega$	1.65 to 4.30		25				pC	Figure 12
OIRR	Off Isolation	$f=100\ \text{kHz}$, $R_L=50\ \Omega$, $C_L=0\ \text{pF}$	1.65 to 4.30		-70				dB	Figure 10
Xtalk	Crosstalk	$f=100\ \text{kHz}$, $R_L=50\ \Omega$, $C_L=0\ \text{pF}$	1.65 to 4.30		-70				dB	Figure 11
BW	-3 db Bandwidth	$R_L=50\ \Omega$, $C_L=0\ \text{pF}$	1.65 to 4.30		>50				MHz	Figure 9
THD	Total Harmonic Distortion	$f=20\ \text{Hz}$ to $20\ \text{kHz}$, $R_L=32\ \Omega$, $V_{IN}=2\ \text{V}_{pp}$, $V_{BIAS}=0\ \text{V}$	1.65 to 4.30		.06				%	Figure 15

Capacitance

Symbol	Parameter	Conditions	V_{CC} (V)	$T_A=+25^\circ\text{C}$			Units	Figure
				Min.	Typ.	Max.		
C_{IN}	Control Pin Input Capacitance	$f=1\ \text{MHz}$	0		2.5		pF	Figure 13
C_{OFF}	B Port Off Capacitance	$f=1\ \text{MHz}$	3.3		30		pF	Figure 13
C_{ON}	A Port On Capacitance	$f=1\ \text{MHz}$	3.3		120		pF	Figure 14

Test Diagrams

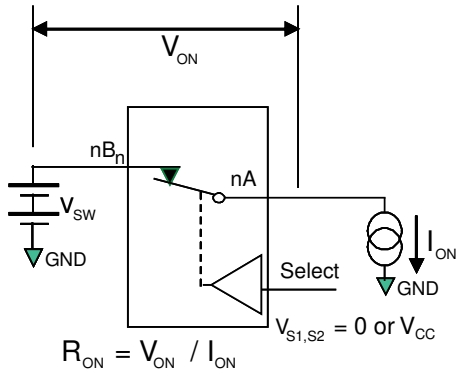
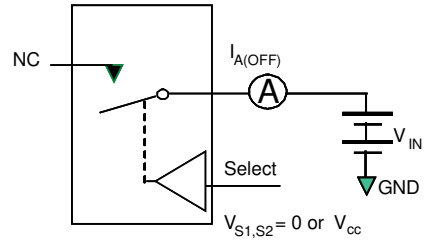

Figure 3. On Resistance



Each switch port is tested separately.

Figure 4. Off Leakage

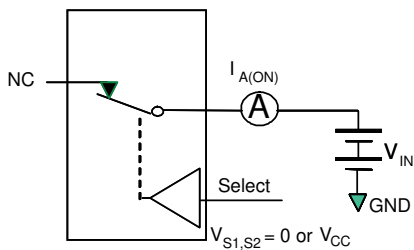

Figure 5. On Leakage

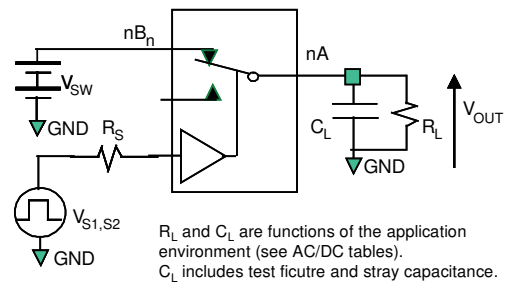

Figure 6. Test Circuit Load

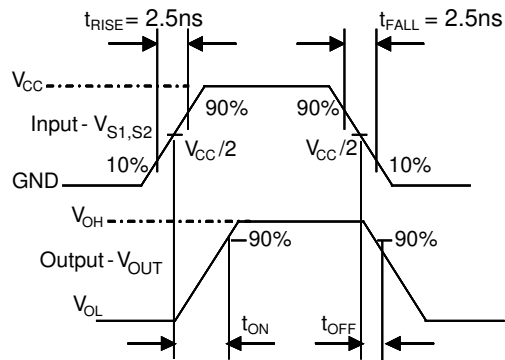

Figure 7. Turn-On / Turn-Off Waveforms

Test Diagrams (Continued)

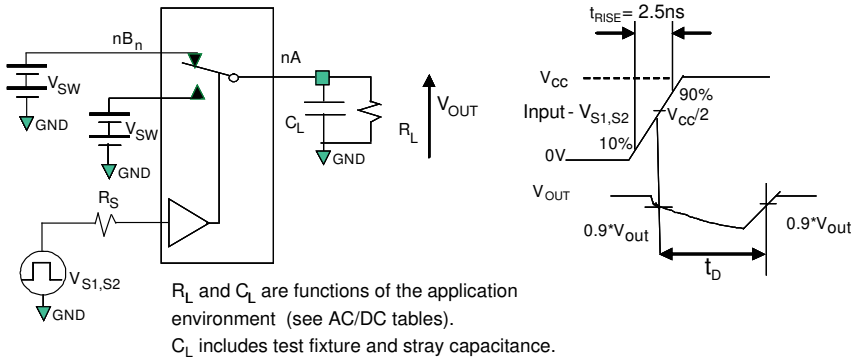

Figure 8. Break-Before-Make Interval Timing

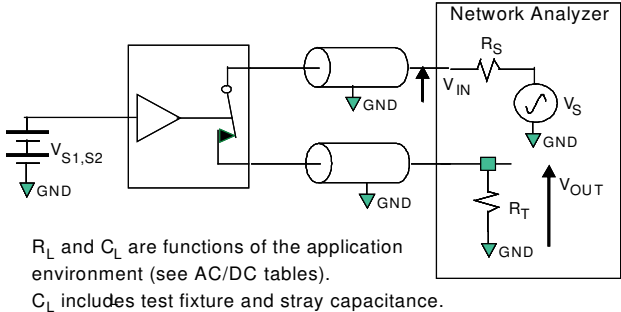

Figure 9. Bandwidth

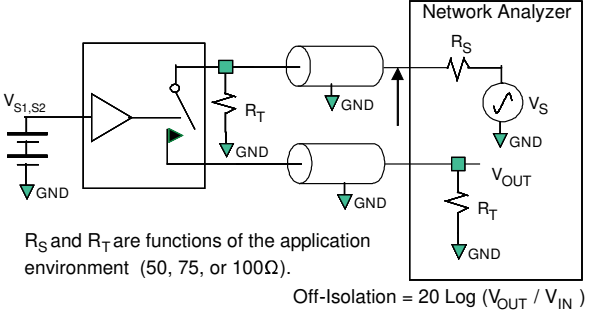

Figure 10. Channel Off Isolation

Test Diagrams (Continued)

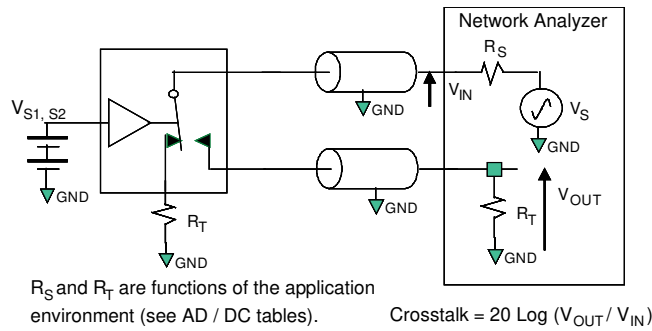

Figure 11. Adjacent Channel Crosstalk

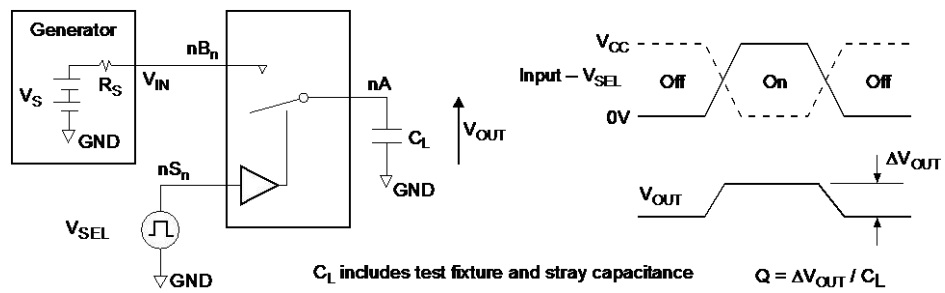

Figure 12. Charge Injection Test

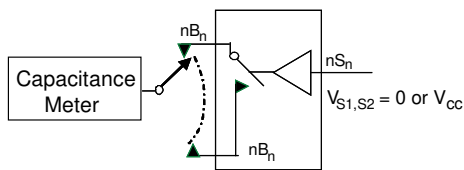

Figure 13. Channel Off Capacitance

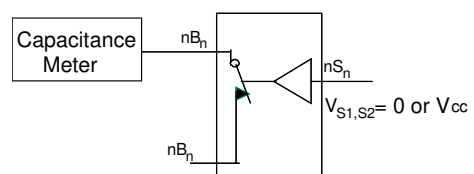

Figure 14. Channel On Capacitance

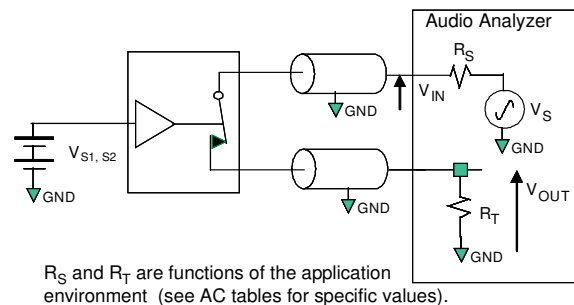

Figure 15. Total Harmonic Distortion

Physical Dimensions

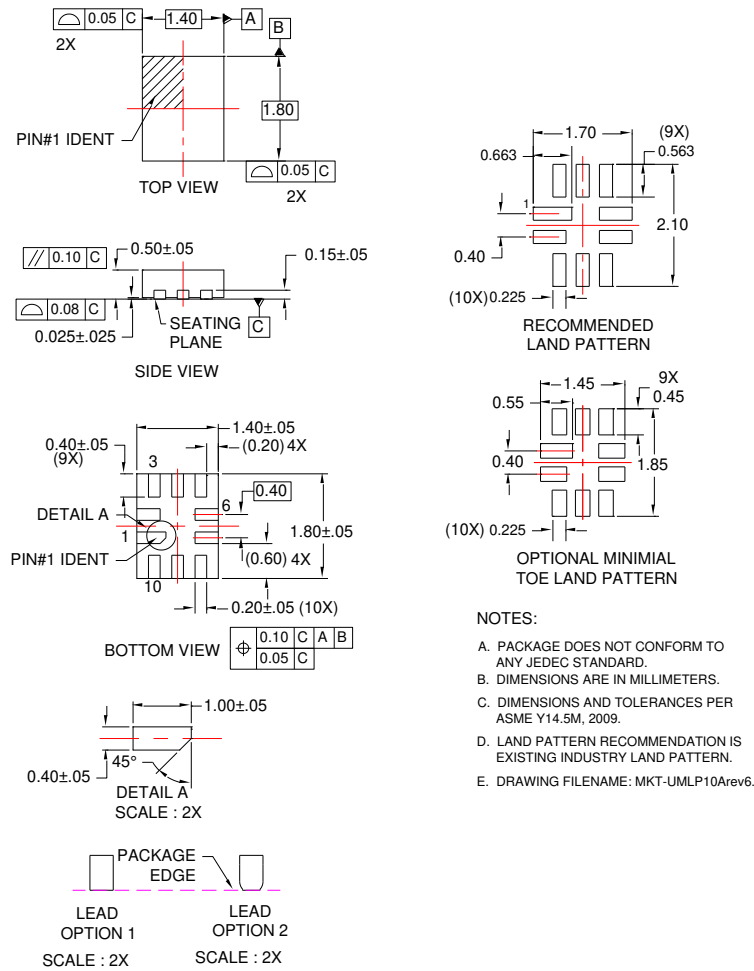

Figure 16. 10-Lead, Quad Ultrathin Molded Leadless Package (UMLP)

Package drawings are provided as a service to customers considering ON Semiconductor components. Drawings may change in any manner without notice. Please note the revision and/or date on the drawing and contact a ON Semiconductor representative to verify or obtain the most recent revision. Package specifications do not expand the terms of ON Semiconductor's worldwide terms and conditions, specifically the warranty therein, which covers ON Semiconductor products.

Table 1. Nominal Values

JEDEC Symbol	Description	Nominal Values (mm)
A	Overall Height	0.5
A1	Package Standoff	0.026
A3	Lead Thickness	0.152
b	Lead Width	0.2
L	Lead Length	0.4
e	Lead Pitch	0.4
D	Body Length (Y)	1.8
E	Body Width (X)	1.4

ON Semiconductor and the ON Semiconductor logo are trademarks of Semiconductor Components Industries, LLC dba ON Semiconductor or its subsidiaries in the United States and/or other countries. ON Semiconductor owns the rights to a number of patents, trademarks, copyrights, trade secrets, and other intellectual property. A listing of ON Semiconductor's product/patent coverage may be accessed at www.onsemi.com/site/pdf/Patent-Marking.pdf. ON Semiconductor reserves the right to make changes without further notice to any products herein. ON Semiconductor makes no warranty, representation or guarantee regarding the suitability of its products for any particular purpose, nor does ON Semiconductor assume any liability arising out of the application or use of any product or circuit, and specifically disclaims any and all liability, including without limitation special, consequential or incidental damages. Buyer is responsible for its products and applications using ON Semiconductor products, including compliance with all laws, regulations and safety requirements or standards, regardless of any support or applications information provided by ON Semiconductor. "Typical" parameters which may be provided in ON Semiconductor data sheets and/or specifications can and do vary in different applications and actual performance may vary over time. All operating parameters, including "Typicals" must be validated for each customer application by customer's technical experts. ON Semiconductor does not convey any license under its patent rights nor the rights of others. ON Semiconductor products are not designed, intended, or authorized for use as a critical component in life support systems or any FDA Class 3 medical devices or medical devices with a same or similar classification in a foreign jurisdiction or any devices intended for implantation in the human body. Should Buyer purchase or use ON Semiconductor products for any such unintended or unauthorized application, Buyer shall indemnify and hold ON Semiconductor and its officers, employees, subsidiaries, affiliates, and distributors harmless against all claims, costs, damages, and expenses, and reasonable attorney fees arising out of, directly or indirectly, any claim of personal injury or death associated with such unintended or unauthorized use, even if such claim alleges that ON Semiconductor was negligent regarding the design or manufacture of the part. ON Semiconductor is an Equal Opportunity/Affirmative Action Employer. This literature is subject to all applicable copyright laws and is not for resale in any manner.

PUBLICATION ORDERING INFORMATION

LITERATURE FULFILLMENT:

Literature Distribution Center for ON Semiconductor
 19521 E. 32nd Pkwy, Aurora, Colorado 80011 USA
Phone: 303-675-2175 or 800-344-3860 Toll Free USA/Canada
Fax: 303-675-2176 or 800-344-3867 Toll Free USA/Canada
Email: orderlit@onsemi.com

N. American Technical Support: 800-282-9855 Toll Free
 USA/Canada.

Europe, Middle East and Africa Technical Support:
 Phone: 421 33 790 2910

Japan Customer Focus Center
 Phone: 81-3-5817-1050

ON Semiconductor Website: www.onsemi.com

Order Literature: <http://www.onsemi.com/orderlit>

For additional information, please contact your local
 Sales Representative