

PART NUMBER	SML-LX2832IGC-TR	REV.	E
DATE	E.C.N. NUMBER AND REVISION COMMENTS		REV.
03.14.03	E.C.N. #10967.		A
02.08.05	E.C.N. #11148.		B
10.17.07	E.C.N. #11450.		C
06.20.08	E.C.N. #11511.		D
05.04.10	E.C.N. #11627.		E

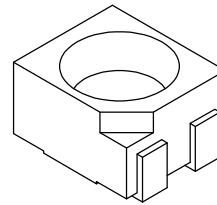
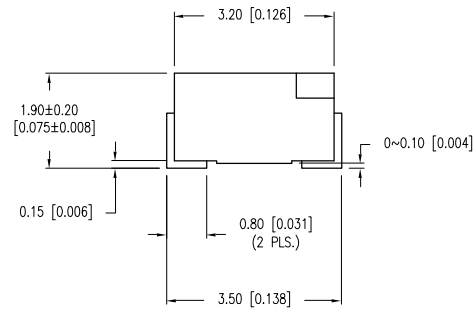
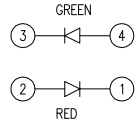
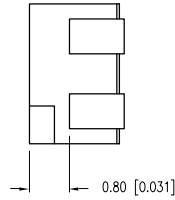
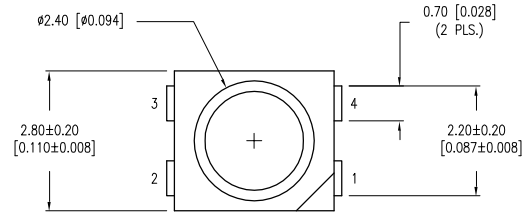

ELECTRO-OPTICAL CHARACTERISTICS $T_A=25^{\circ}\text{C}$ $I_f=20\text{mA}$

PARAMETER	COLOR	MIN	TYP	MAX	UNITS	TEST COND
PEAK WAVELENGTH			635		nm	
			565		nm	
FORWARD VOLTAGE	(R/G)		2.0/2.2	2.5/2.6	V_f	
REVERSE VOLTAGE		5.0			V_r	$I_f=100\mu\text{A}$
AXIAL INTENSITY	(R/G)		25/25		mcd	$I_f=20\text{mA}$
VIEWING ANGLE			120		$2x$ theta	
EMITTED COLOR:	RED/GREEN					
EPOXY LENS FINISH:	WATER CLEAR					

LIMITS OF SAFE OPERATION AT 25°C PER CHIP

PARAMETER	MAX	UNITS
PEAK FORWARD CURRENT*	160	mA
STEADY CURRENT (R/G)	30/25	mA
POWER DISSIPATION	100	mW
DERATE FROM 25°C	-1.2	mW/ $^{\circ}\text{C}$
OPERATING TEMP.	-25 TO +85	$^{\circ}\text{C}$
STORAGE TEMP.	-30 TO +85	$^{\circ}\text{C}$
SOLDERING TEMP.	+260	$^{\circ}\text{C}$
2.0mm FROM BODY	3	SEC. MAX

* $t < 10\mu\text{s}$

B LEAD FREE REFLOW PROFILE
10 SEC. MAX.

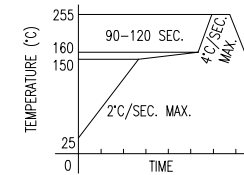

TOTAL TIME ABOVE 220°C IS 60 SECONDS MAX.

NOTES:

- THE POLARITY MARK IS ORIENTED TOWARDS THE TAPE SPROCKET HOLE.

E A CAUTION: MOISTURE SENSITIVE DEVICE
PER JEDEC LEVEL 2 STANDARDS

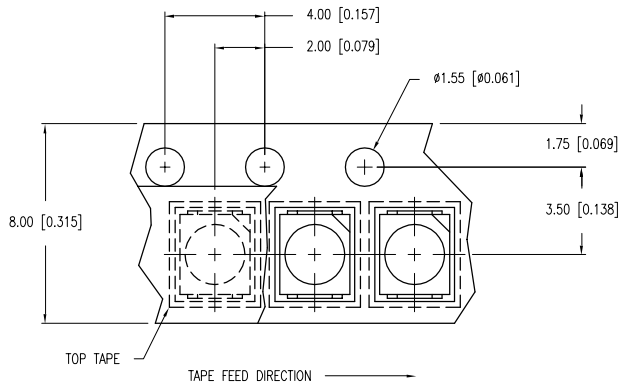

D C RECOMMENDED SOLDER PAD LAYOUT

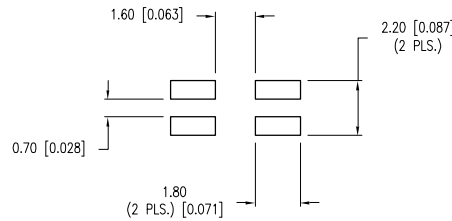

*UNLESS OTHERWISE SPECIFIED TOLERANCES PER DECIMAL PRECISION ARE: $x=\pm 1$ (± 0.039), $X.X=\pm 0.5$ (± 0.020), $X.XX=\pm 0.25$ (± 0.010), $X.XXX=\pm 0.127$ (± 0.005). LEAD SIZE= ± 0.05 (± 0.002), LEAD LENGTH= ± 0.75 (± 0.030). MIN= $\frac{+0.00}{-0.00}$ DECIMAL PRECISION MAX= $\frac{+0.00}{-0.00}$ DECIMAL PRECISION UNCONTROLLED DOCUMENT



290 E. HELEN ROAD
PALATINE, IL 60067-6976
PHONE: +1.847.359.2790
FAX: +1.847.359.6538
WEB: WWW.LUMEX.COM

2.8mm x 3.2mm SML /W REFLECTOR CUP, DUAL CHIP, 635nm/565nm LED, WATER CLEAR LENS, 2k PER REEL.

THE SPECIFICATIONS MAY CHANGE AT ANY TIME WITHOUT NOTICE DUE TO NEW MATERIALS OR PRODUCT IMPROVEMENT.

CONFIDENTIAL INFORMATION
THE INFORMATION CONTAINED IN THIS DOCUMENT IS THE PROPERTY OF LUMEX INC. EXCEPT AS SPECIFICALLY AUTHORIZED IN WRITING BY LUMEX INC., THE HOLDER OF THIS DOCUMENT SHALL KEEP ALL INFORMATION CONTAINED HEREIN CONFIDENTIAL AND SHALL PROTECT SAME IN WHOLE OR IN PART FROM DISCLOSURE AND DISSEMINATION TO ALL THIRD PARTIES.

DATE: 09.28.00	DRAWN BY: CT
PAGE: 1 OF 1	CHKD BY: SS
SCALE: N/A	APRVD BY: KF
UNIT: mm [INCH]	