

MOUNTING DETAIL

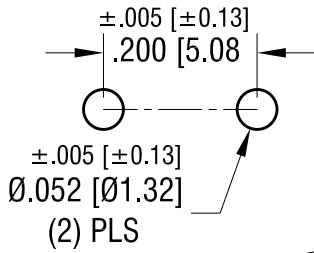

THIS DOCUMENT IS THE PROPERTY OF KEYSTONE ELECTRONICS CORP. AND SHALL NOT BE REPRODUCED, DISTRIBUTED OR USED AS A BASIS FOR MANUFACTURE WITHOUT PRIOR WRITTEN PERMISSION FROM KEYSTONE ELECTRONICS CORP.

ACTUAL SIZE

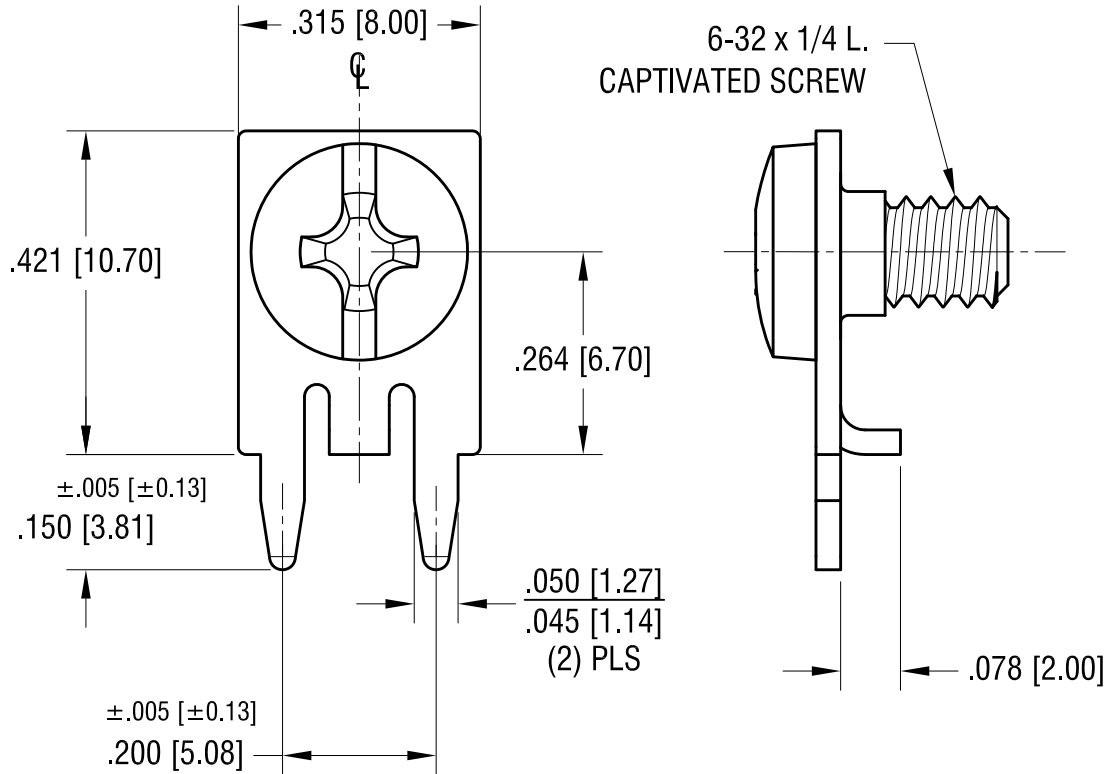
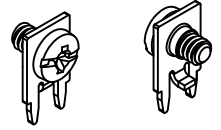

NOTE:

1. TERMINAL:
MAT'L - .032 [0.81] TH'K BRASS, TIN PLATE
2. SCREW : 6-32 TH'D x 1/4 L.
MAT'L - BRASS, NICKEL PLATE
SCREW SUPPLIED CAPTIVATED

KEYSTONE ELECTRONICS CORP.			
www.keyelco.com • NEW HYDE PARK, NY 11040 • Tel (516) 328-7500			
PART NAME		SCREW TERMINAL	
MATERIAL		AS NOTED	
FINISH	AS NOTED	DRN BY NT	DATE 3.14.19
		APP'D LN	SCALE 4X
TOLERANCES	INCH [MM]	CODE	DWG NO.
DECIMAL	± .010 [± 0.25]	C	7757
ANGULAR	± 1°		
UNLESS OTHERWISE SPECIFIED			

DATE	DESCRIPTION	REV.