

# BQ27427 EVM: Single-Cell Impedance Track Technology



## ABSTRACT

This evaluation module (EVM) is a complete evaluation system for the BQ27427. The EVM includes one BQ27427 circuit module with an integrated current-sense resistor. A separated orderable EV2400 PC interface board for gas gauge interface along with a PC USB cable, and Microsoft® Windows® based PC software is needed when using this EVM. The circuit module includes one BQ27427 integrated circuit and all other onboard components necessary to monitor and predict capacity for a system-side fuel gauge solution. The circuit module connected with the EV2400 interface board and software, the user can:

- Read the BQ27427 data registers
- Update the RAM for different configurations
- Log cycling data for further evaluation
- Evaluate the overall functionality of the BQ27427 solution under different charge and discharge conditions

The latest Windows-based PC software can be downloaded from the product folder on the Texas Instruments Web site.

---

## Table of Contents

<b>1 Features</b> .....	3
1.1 Kit Contents.....	3
1.2 Ordering Information.....	3
<b>2 BQ27427-Based Circuit Module</b> .....	4
2.1 Circuit Module Connections.....	4
2.2 Pin Descriptions.....	4
<b>3 Evaluation Module Physical Layout, Bill of Materials and Schematic</b> .....	5
3.1 Board Layout.....	5
3.2 Bill of Materials.....	6
3.3 Schematic.....	7
3.4 BQ27427 Circuits Module Performance Specification Summary.....	7
<b>4 EVM Hardware and Software Setup</b> .....	8
4.1 Software Installation.....	8
<b>5 Troubleshooting Unexpected Dialog Boxes</b> .....	8
<b>6 Hardware Connection</b> .....	8
6.1 Connecting the BQ27427 Circuit Module to a Battery Pack.....	8
6.2 PC Interface Connection.....	8
<b>7 Operation</b> .....	10
7.1 Starting the Program.....	10
7.2 Setting Programmable BQ27427 Options.....	11
<b>8 Calibration</b> .....	13
8.1 Calibrating the BQ27427.....	13
8.2 Voltage Calibration.....	13
8.3 Board Offset Calibration.....	13
<b>9 Advanced Communication I<sup>2</sup>C</b> .....	14
9.1 I <sup>2</sup> C Communication.....	14
<b>10 Related Documentation</b> .....	16
<b>11 Revision History</b> .....	16

## List of Figures

Figure 3-1. BQ27427EVM Layout – Top Silk.....	5
Figure 3-2. BQ27427EVM Layout - Mid Layer 2.....	5
Figure 3-3. BQ27427EVM Layout – Mid Layer 3.....	6

Figure 3-4. BQ27427EVM Layout – Bottom Layer.....	6
Figure 3-5. BQ27427EVM Schematic.....	7
Figure 6-1. BQ27427 Circuit Module Connection to Pack and System Load/Charger.....	8
Figure 7-1. Registers Screen.....	10
Figure 7-2. bqStudio Default Page.....	11
Figure 7-3. Data Memory Screen.....	12
Figure 8-1. Calibration Screen.....	13
Figure 9-1. Advanced Communication I <sup>2</sup> C.....	14
Figure 9-2. Parameter Q&A Screen.....	14
Figure 9-3. Golden Image Output Screen.....	15
Figure 9-4. Gauge Programming Screen.....	15

## List of Tables

Table 1-1. Ordering Information.....	3
Table 2-1. Pin Descriptions.....	4
Table 3-1. Bill of Materials.....	6
Table 3-2. Performance Specification Summary.....	8
Table 6-1. Circuit Module to EV2400 Connections.....	9

## Trademarks

Impedance Track™ is a trademark of Texas Instruments.

Microsoft® and Windows® are registered trademarks of Microsoft Corporation.

All trademarks are the property of their respective owners.

## 1 Features

- Complete evaluation system for the BQ27427 gas gauge with Impedance Track™ technology
- Populated circuit module for quick setup
- Personal computer (PC) software and interface board for easy evaluation
- Software that allows data logging for system analysis

### 1.1 Kit Contents

- BQ27427 evaluation module (BMS037)

This EVM is used for the evaluation of the BQ27427 battery gauge. Visit the product Web folder at [www.ti.com](http://www.ti.com) and download the TRM for information how to configure the BQ27427.

### 1.2 Ordering Information

**Table 1-1. Ordering Information**

Part Number	EVM Part Number
BQ27427	BQ27427EVM

## 2 BQ27427-Based Circuit Module

The BQ27427-based circuit module is a complete and compact example solution of a BQ27427 circuit for battery management. The circuit module incorporates a BQ27427 battery gas gauge integrated circuit (IC) with integrated sense resistor and all other components necessary to accurately predict the capacity of a 1-series Li-ion cell.

### 2.1 Circuit Module Connections

Contacts on the circuit module provide the following connections:

- Direct connection to the battery pack (J5): PACK+, PACK–
- To the serial communications port (J10): SDA, SCL, and VSS
- The system load and charger connect across charger and load (J6 and J7): CHARGER+/LOAD+ and CHARGER–/LOAD–.
- Access to signal outputs (J1 and J5): BIN and GPOUT
- External connect to power the IC (J4): EXT VDD and VSS

### 2.2 Pin Descriptions

**Table 2-1. Pin Descriptions**

Pin Name	Description
PACK+	Pack positive terminal
PACK–	Pack negative terminal
SDA	I2C communication data lin
EXT VDD	External supply connection
SCL	I2C communication clock line
VSS	Signal return for communication line, shared with charger and ground
CHARGER+/LOAD+	High potential of load or charger connection
CHARGER–/LOAD–	Low potential of load or charger connection (system VSS)
BIN	Battery insertion detection input
GPOUT	General purpose output

### 3 Evaluation Module Physical Layout, Bill of Materials and Schematic

This section contains the board layout, bill of materials, and schematic for the BQ27427 evaluation module.

#### 3.1 Board Layout

This section shows the printed-circuit board (PCB) layers (Figure 3-1 through Figure 3-4), and assembly drawing for the BQ27427 module.

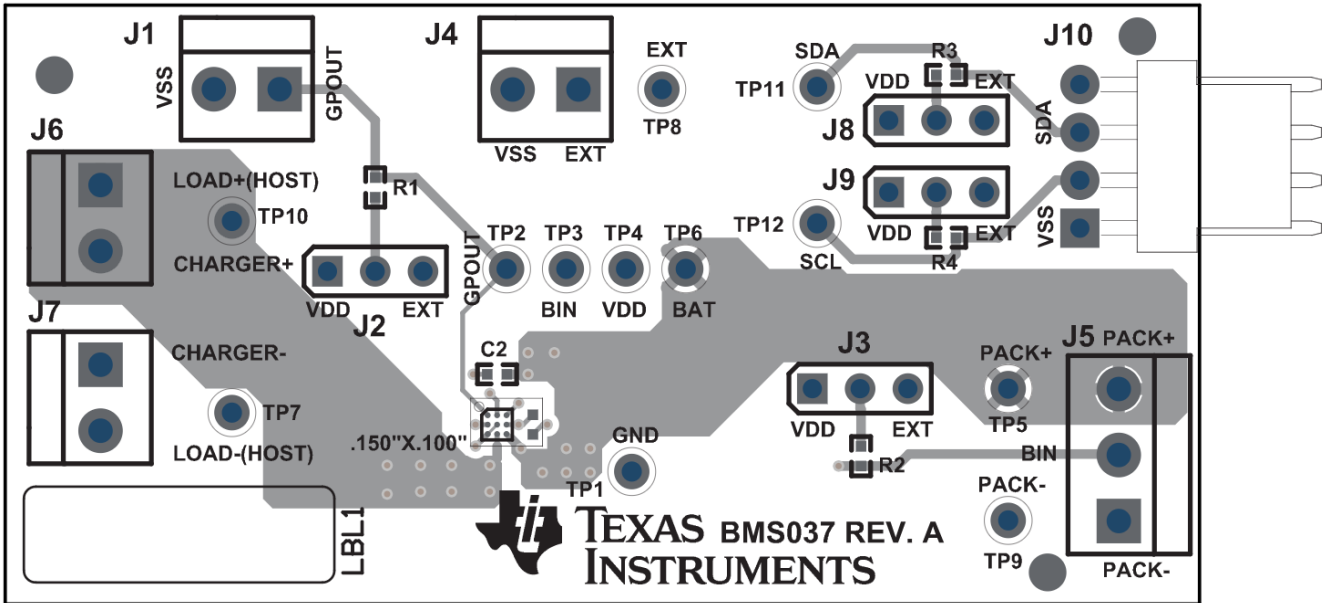

Figure 3-1. BQ27427EVM Layout – Top Silk

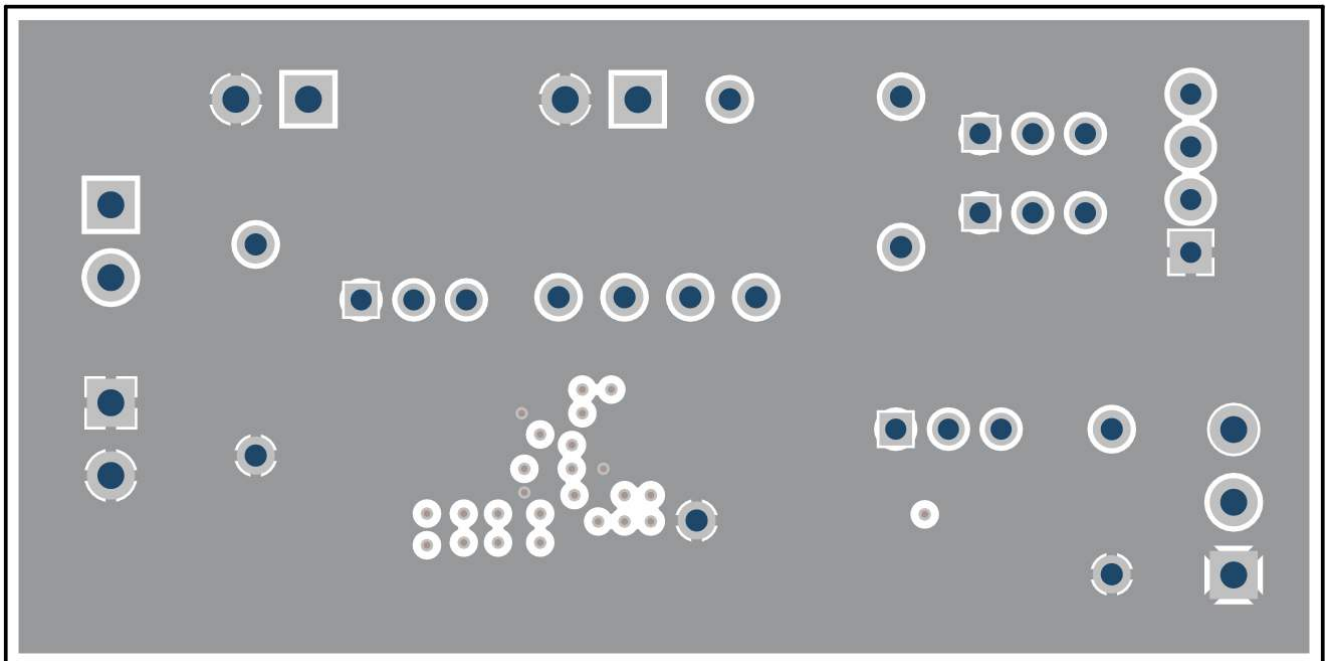

Figure 3-2. BQ27427EVM Layout - Mid Layer 2

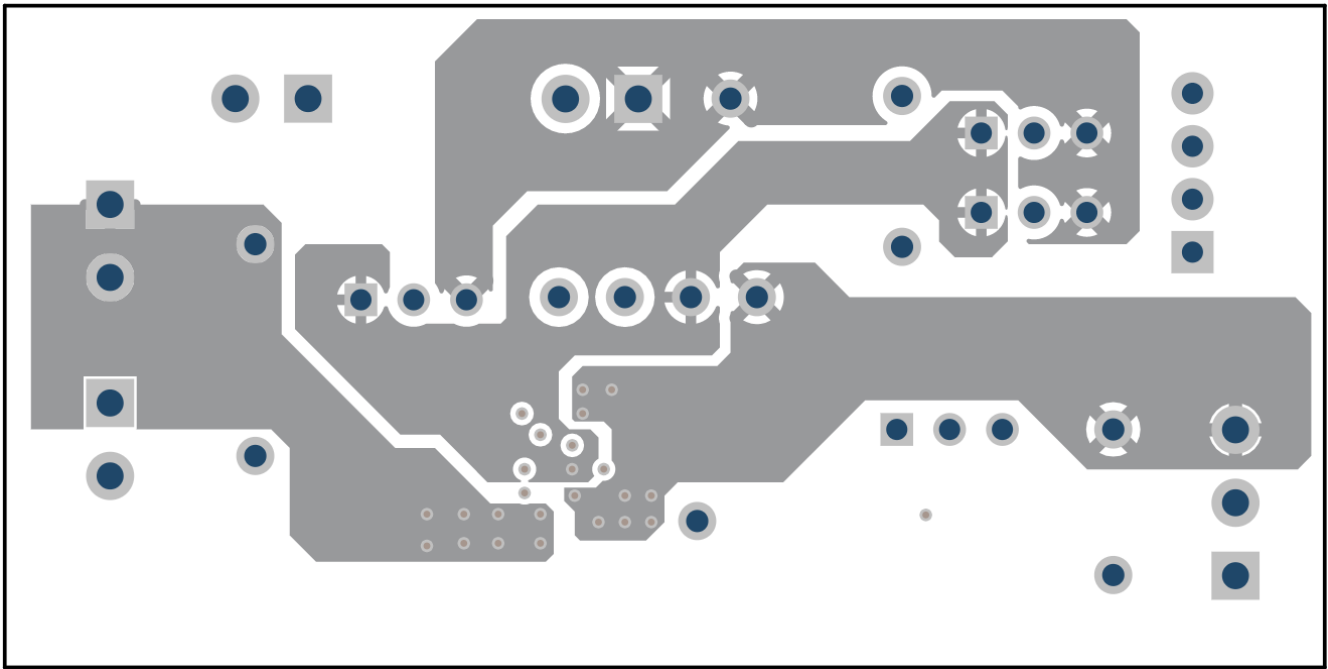

Figure 3-3. BQ27427EVM Layout – Mid Layer 3

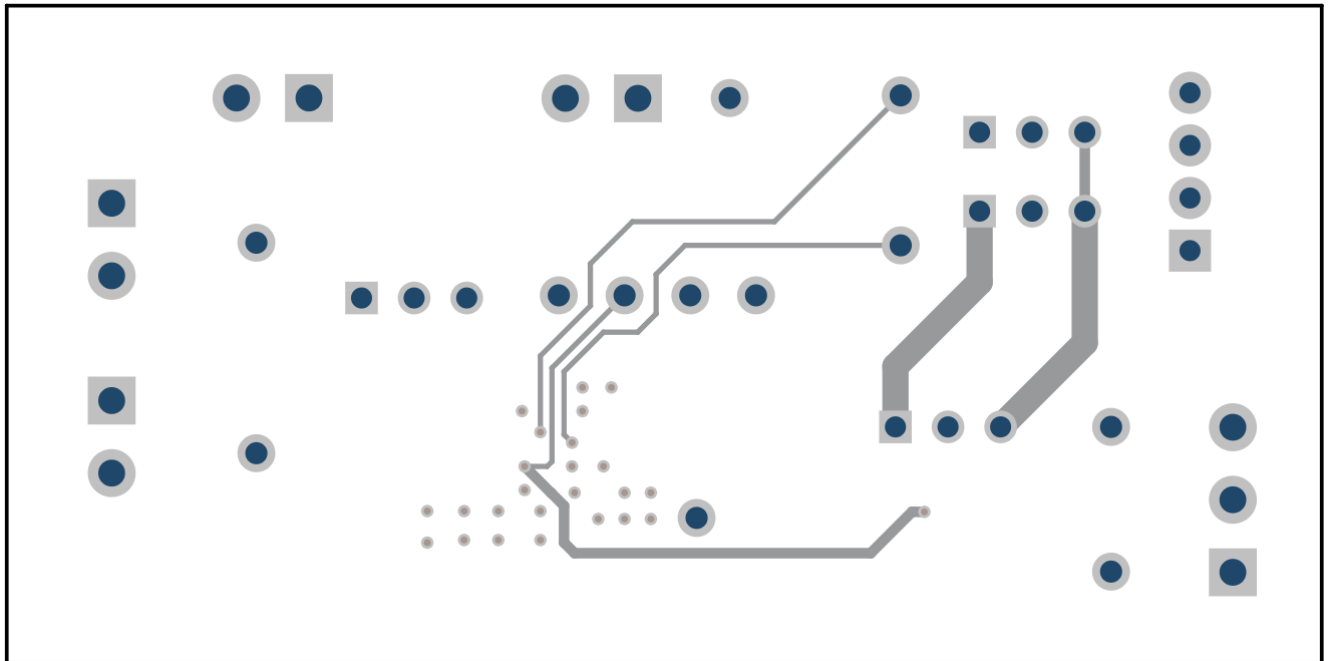

Figure 3-4. BQ27427EVM Layout – Bottom Layer

### 3.2 Bill of Materials

Table 3-1. Bill of Materials

Count	RefDes	Value	Description	Size	Part Number	Mfr
1	C1	0.47	Capacitor, Ceramic, 6.3V, X5R, 20%	0402		
1	C2	1	Capacitor, Ceramic, 6.3V, X5R, 10%	0402		

**Table 3-1. Bill of Materials (continued)**

Count	RefDes	Value	Description	Size	Part Number	Mfr
4	J1,J4,J6,J7	ED555/2DS	Terminal Block, 2-pin, 6-A, 3.5mm	0.27 x 0.25 inch	ED555/2DS	OST
4	J2,J3,J8,J9	PEC36SAAN	Header, Male 3-pin, 100mil spacing	0.100 inch x 3	PEC36SAAN	Sullins
1	J5	ED555/3DS	Terminal Block, 3-pin, 6-A, 3.5mm	0.41 x 0.25 inch	ED555/3DS	OST
1	J10	22-05-3041	Header, Friction Lock Ass'y, 4-pin Right Angle	0.400 x 0.500	22-05-3041	Molex
1	R1	14.7k	Resistor, Chip, 1/16-W, 5%	0402	Std	Std
1	R2	10k	Resistor, Chip, 1/16-W, 5%	0402	Std	Std
2	R3,R4	5.1k	Resistor, Chip, 1/16-W, 5%	0402	Std	Std
4	TP1,TP7,TP9	5001	Test Point, Black, Thru Hole Color Keyed	0.100 x 0.100 inch	5001	Keystone
7	TP2,TP3,TP11,TP12	5002	Test Point, White, Thru Hole Color Keyed	0.100 x 0.100 inch	5002	Keystone
3	TP4,TP5,T6,TP10	5000	Test Point, Red, Thru Hole Color Keyed	0.100 x 0.100 inch	5000	Keystone
1	U1	BQ27427YZF	IC, Battery Gauge	DSBGA	BQ27427	TI

### 3.3 Schematic

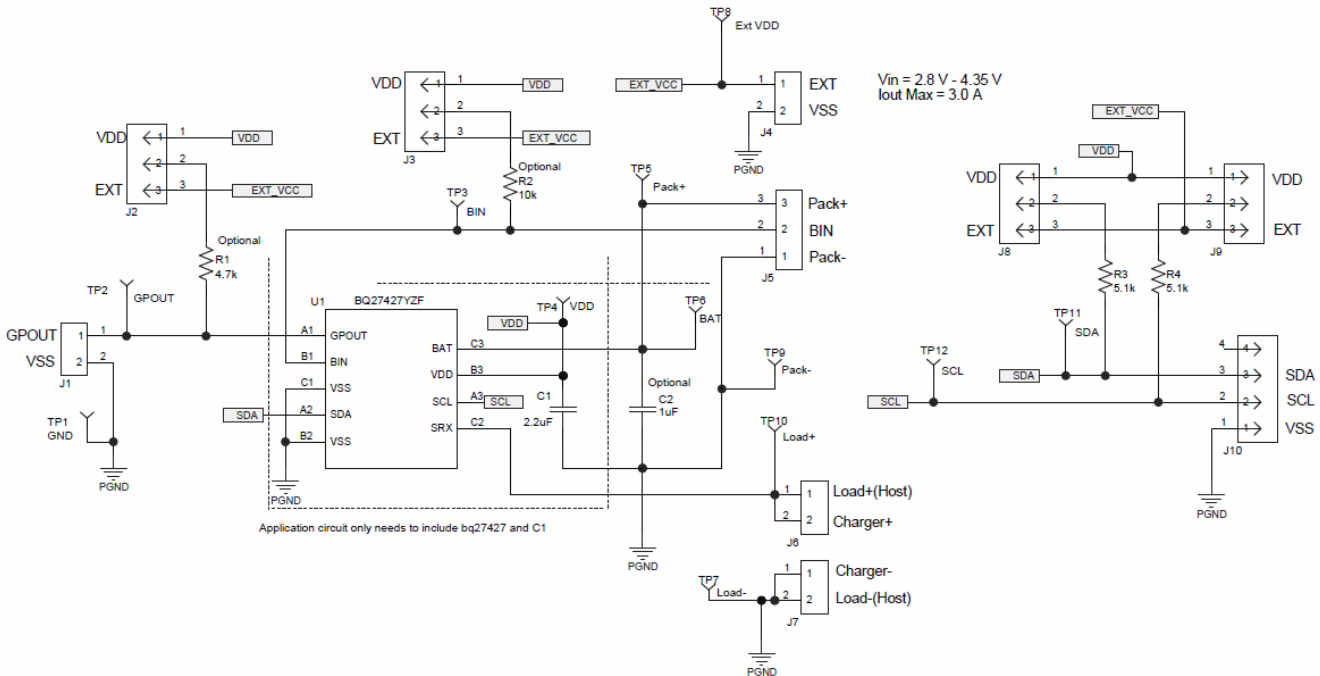

**Figure 3-5. BQ27427EVM Schematic**

### 3.4 BQ27427 Circuits Module Performance Specification Summary

This section summarizes the performance specifications of the BQ27427 circuit module.

**Table 3-2. Performance Specification Summary**

Specification	Min	Typ	Max	Units
Input voltage Pack+ to Pack-	2.7	3.6	4.3	V
Charge and discharge current	0	1	2.5	A

## 4 EVM Hardware and Software Setup

This section describes how to install the BQ27427EVM PC software and how to connect the different components of the EVM.

### 4.1 Software Installation

Find the latest software version at <https://www.ti.com/tool/bqStudio>. Use the following steps to install Battery Management Studio:

1. Ensure that the EV2400 is not connected to the PC through a USB cable before starting this procedure.
2. Select the Tool and Software tab in the product folder
3. Under the Software section, click on Battery Management Studio (bqStudio) Software Suite.
4. Click the Download button to download the software.
5. Download software to hard drive.
6. Double-click the software executable and follow all instructions and prompts.

### 5 Troubleshooting Unexpected Dialog Boxes

The user that is downloading the files must be logged in as the administrator. The driver is not signed, so the administrator must allow installation of unsigned drivers in the operating system.

### 6 Hardware Connection

The BQ27427 evaluation system comprises three hardware components: the BQ27427 evaluation module, the EV2300 or EV2400 PC interface board, and the PC.

#### 6.1 Connecting the BQ27427 Circuit Module to a Battery Pack

Figure 6-1 shows how to connect the BQ27427 circuit module to the cells and system load/charger.

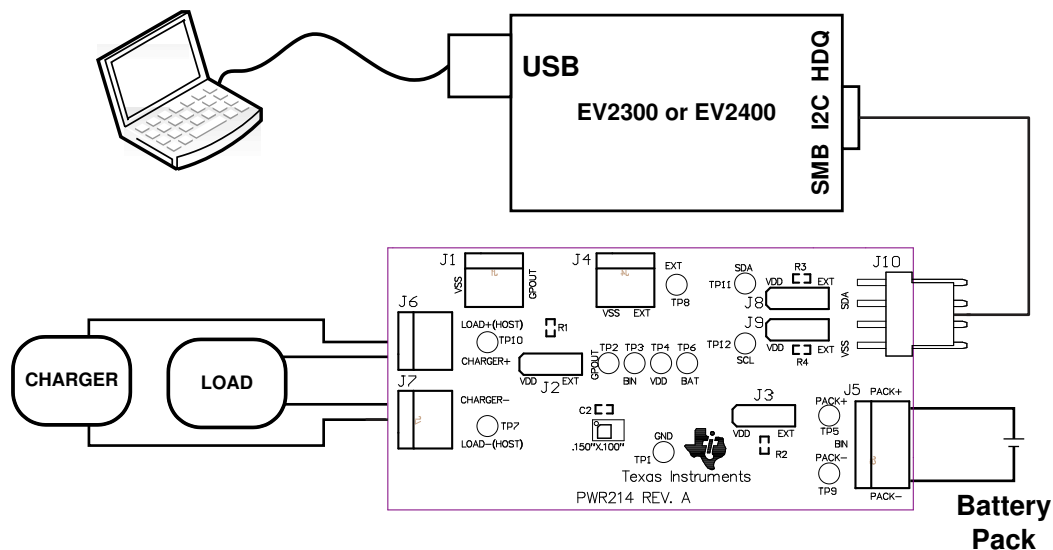
**Figure 6-1. BQ27427 Circuit Module Connection to Pack and System Load/Charger**

#### 6.2 PC Interface Connection

The following steps configure the hardware for interface to the PC.

1. Connect the BQ27427-based EVM to the EV2400 using wire leads as shown in Table 6-1.
2. Connect the PC USB cable to the EV2400 and the PC USB port.



**Table 6-1. Circuit Module to EV2400 Connections**

BQ27427EVM	EV2400
SDA	SDA
SCL	SCL
VSS	GND/VSS

The BQ27427EVM is now set up for operation.

## 7 Operation

This section details the operation of the bqStudio software.

### 7.1 Starting the Program

Run bqStudio from the Start | All Programs | Texas Instruments | Battery Management Studio. The main screen (Figure 7-1) appears. If instead of Figure 7-1 appearing, Figure 7-2 appears, it may mean that the EVM is not connected to the computer correctly. Make sure that the USB interface (EV2400) and the BQ27427 are connected and restart bqStudio. If this still does not resolve the issue, check if the I2C pullup resistors are connected. Data begins to appear once the <Refresh> (single-time scan) button is clicked, or when the Scan button is clicked. To disable the scan feature, simply click the Scan button again.

The continuous scanning period can be set by opening Window | Preferences → Registers section. The range for this interval is 0 ms to 65,535 ms. Only items that are selected for scanning are scanned within this period.

Battery Management Studio provides a logging function which logs the values that were last scanned. To enable this function, select the Start Log button; this causes the Scan button to be pressed. When logging is Stopped, the Scan button will still be selected and has to be manually clicked again.

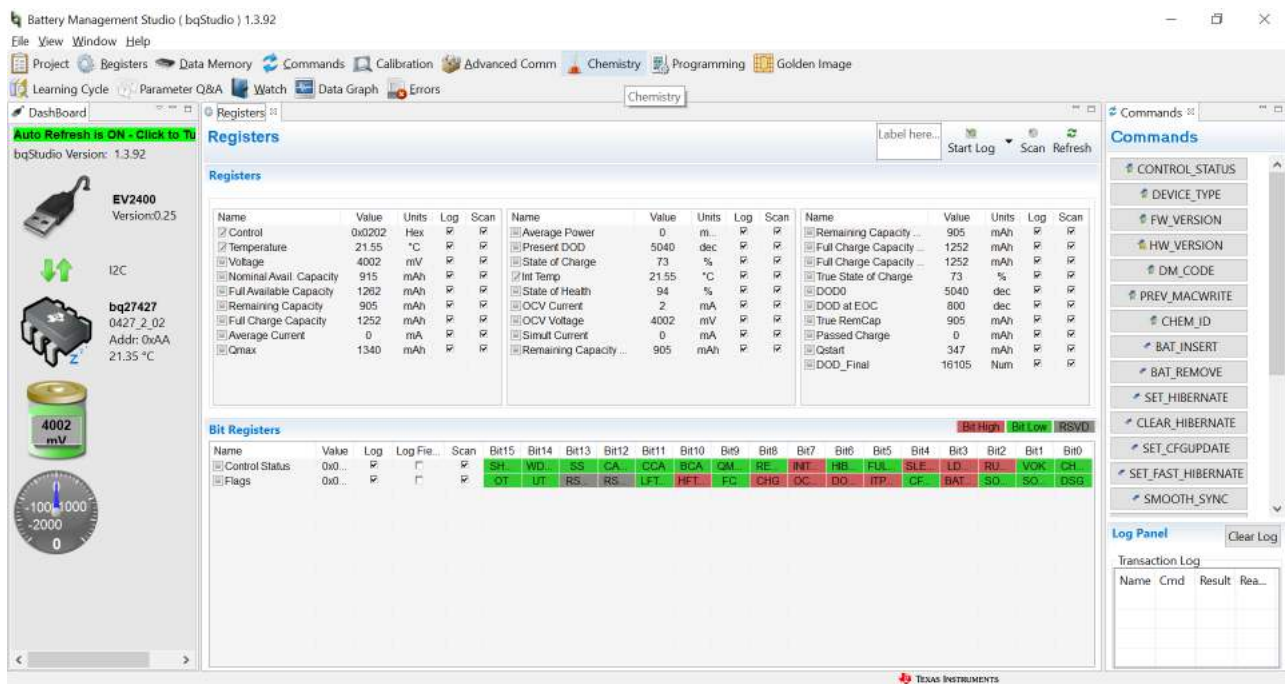
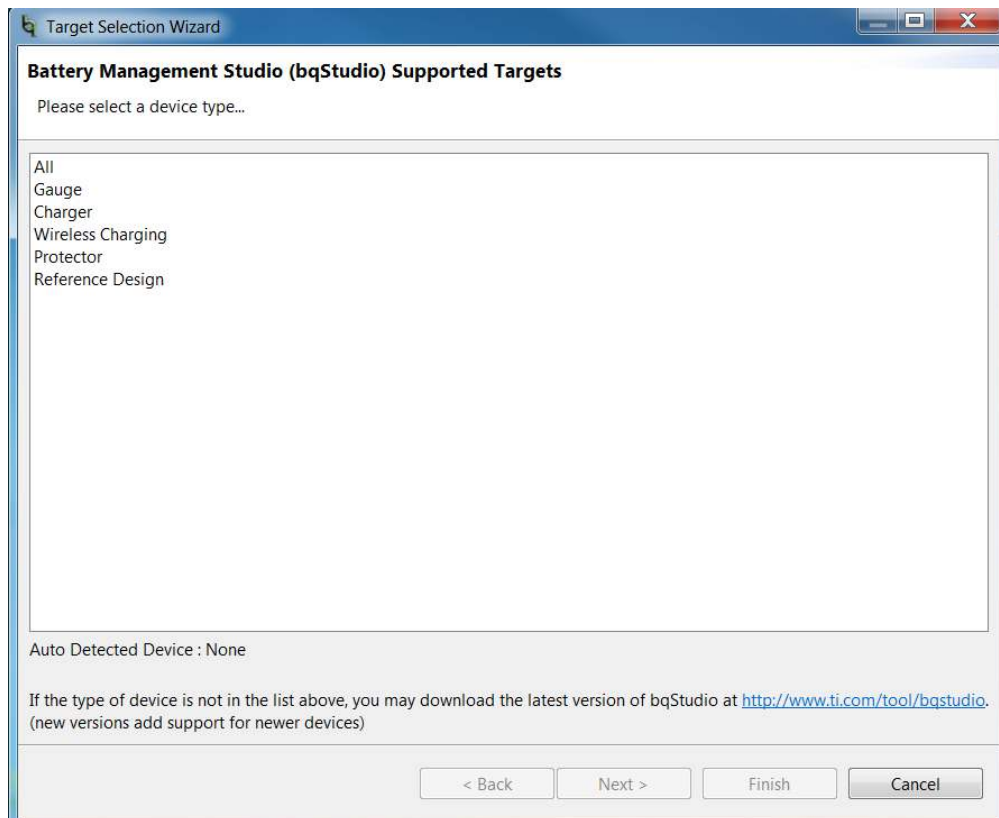

Figure 7-1. Registers Screen

Figure 7-1 shows the main bqStudio window. Additional Flag and Status data can be viewed at the bottom of the Registers window.



**Figure 7-2. bqStudio Default Page**

## 7.2 Setting Programmable BQ27427 Options

The BQ27427 data memory comes configured per the default settings detailed in the BQ27427 technical reference manual ([SLUUAC5](#)). Ensure that the settings are correctly changed to match the pack and application for the BQ27427 solution being evaluated.

**IMPORTANT:** The correct setting of these options is essential to get the best performance. The settings can be configured using the Data Memory screen ([Figure 7-3](#)).

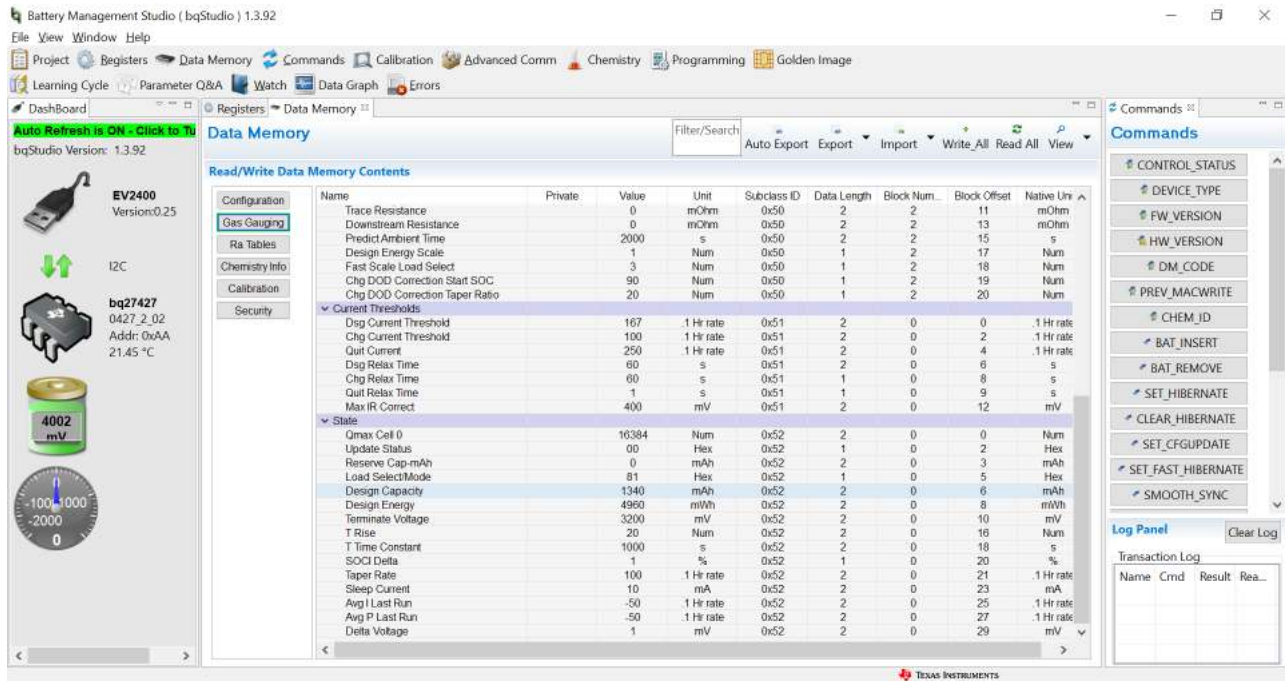

Figure 7-3. Data Memory Screen

Memory window. Make sure the device is not sealed and in full access to read or write to the data memory. To update a parameter, click on the desired parameter and a window pops-up that provides details on the selected parameter. Next, enter the value in the value textbox and press Enter. After pressing Enter, bqStudio updates the selected parameter. The Import button in the Data Memory window can be clicked in order to import an entire configuration from a specified \*.gg.csv file.

Save the configuration to a file by clicking the Export button in the Data Memory window and entering a file name. The configuration is saved to a \*.gg.csv file. The module calibration data is also held in the BQ27427 data memory. If the Gauge Dashboard is not displaying any information, then the BQ27427 may not be supported by the bqStudio version being used, a bqStudio upgrade may be required.

## 8 Calibration

The BQ27427EVM must be calibrated to ensure accurate value reporting. This is done using the Calibration window in bqStudio (Figure 8-1).

### 8.1 Calibrating the BQ27427

1. Select the types of calibration to be performed (see Figure 8-1).
2. Enter the measured values for the types selected.
3. Press the button to calibrate.

### 8.2 Voltage Calibration

Voltage calibration usually is not required. If needed, follow these steps:

1. Measure the voltage across Pack+ and Pack–.
2. Type the voltage value in mV into Enter measured value.
3. Press the Calibrate button.

### 8.3 Board Offset Calibration

This performs the offset calibration for the current offset of the board.

It is expected that no current is flowing through the sense resistor while performing this calibration step.

1. Remove load and short PACK– to LOAD–.
2. Press the Calibrate button

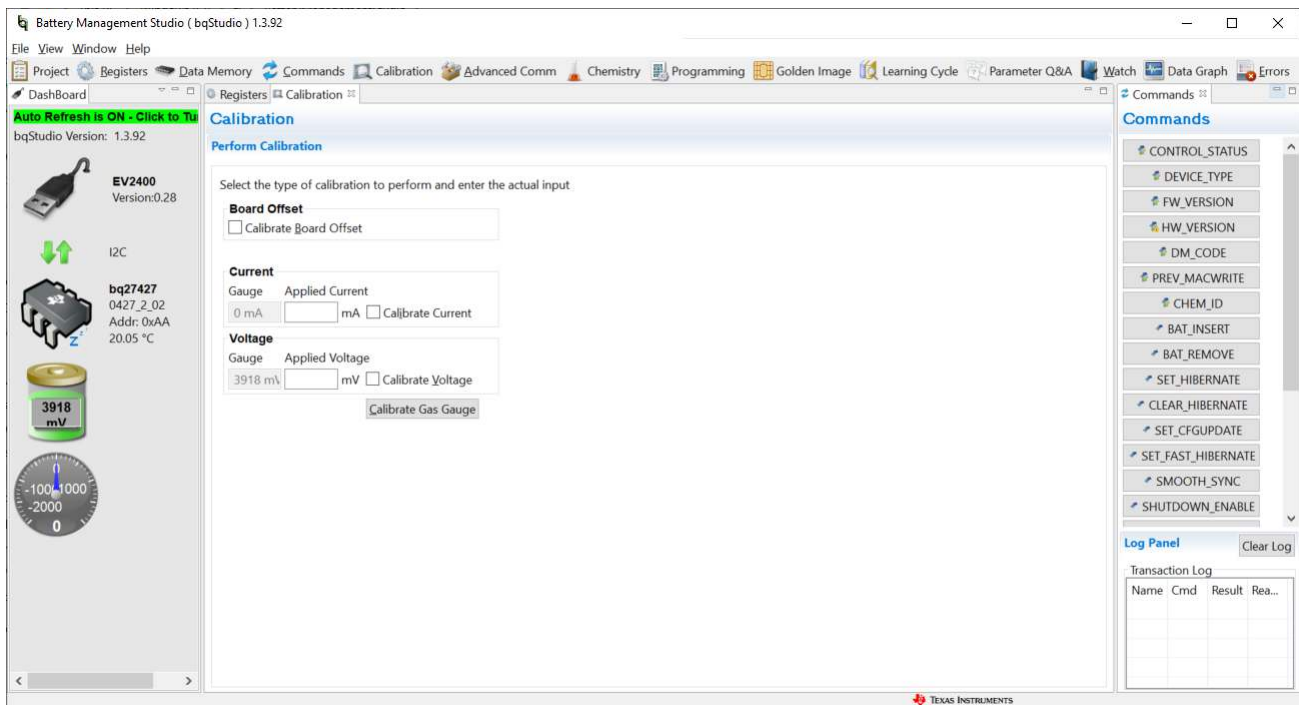

Figure 8-1. Calibration Screen

## 9 Advanced Communication I<sup>2</sup>C

### 9.1 I<sup>2</sup>C Communication

I<sup>2</sup>C read/write operations serve as general-purpose communication tools (Figure 9-1).

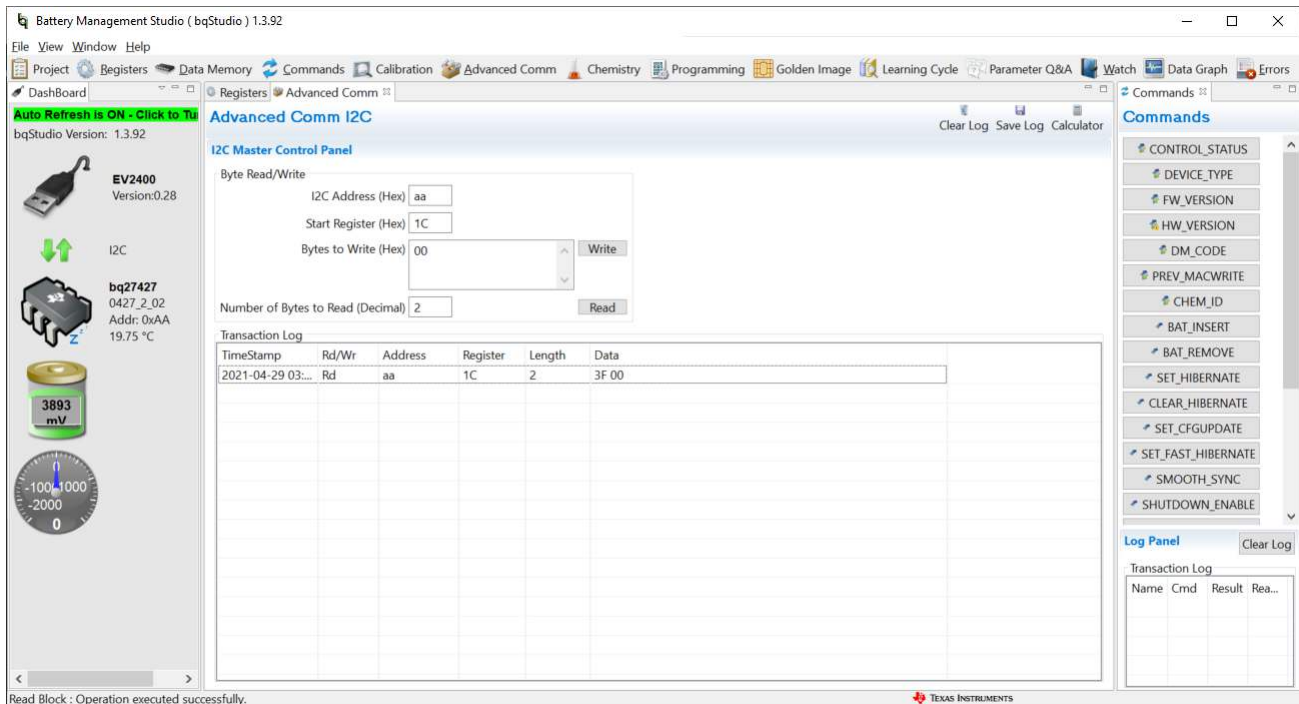

Figure 9-1. Advanced Communication I<sup>2</sup>C

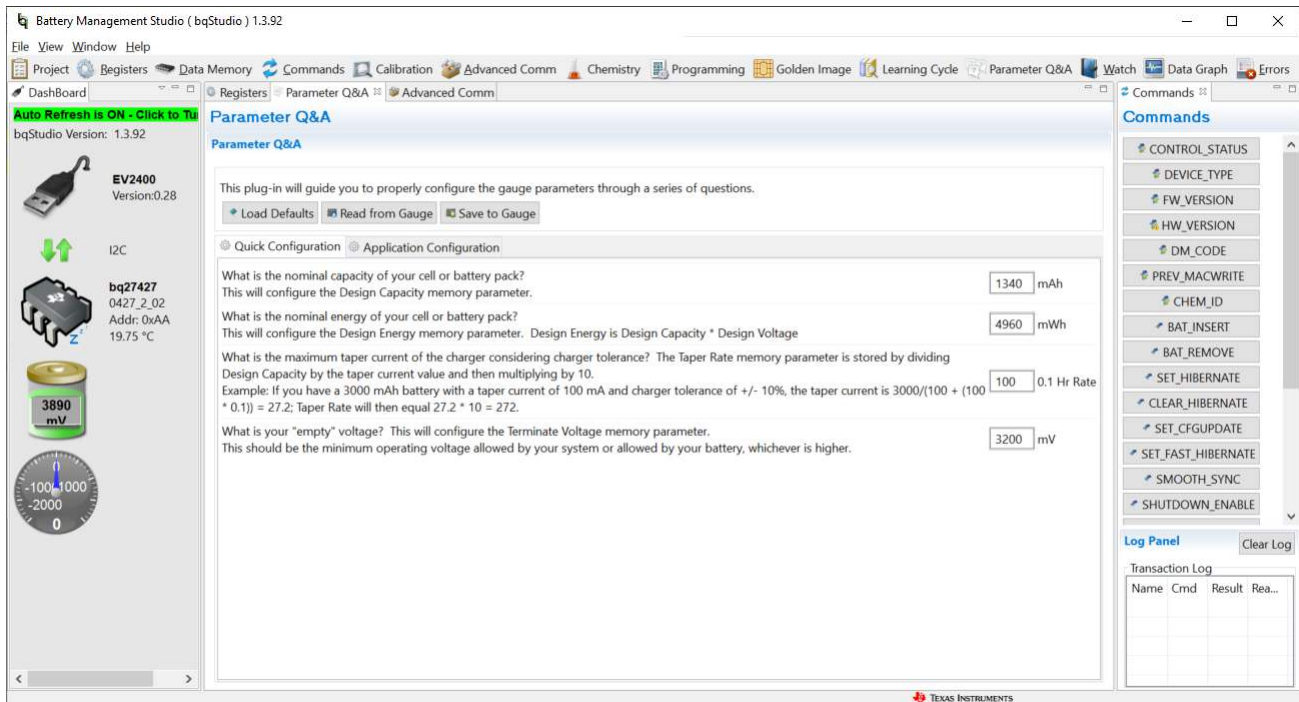

Figure 9-2. Parameter Q&A Screen



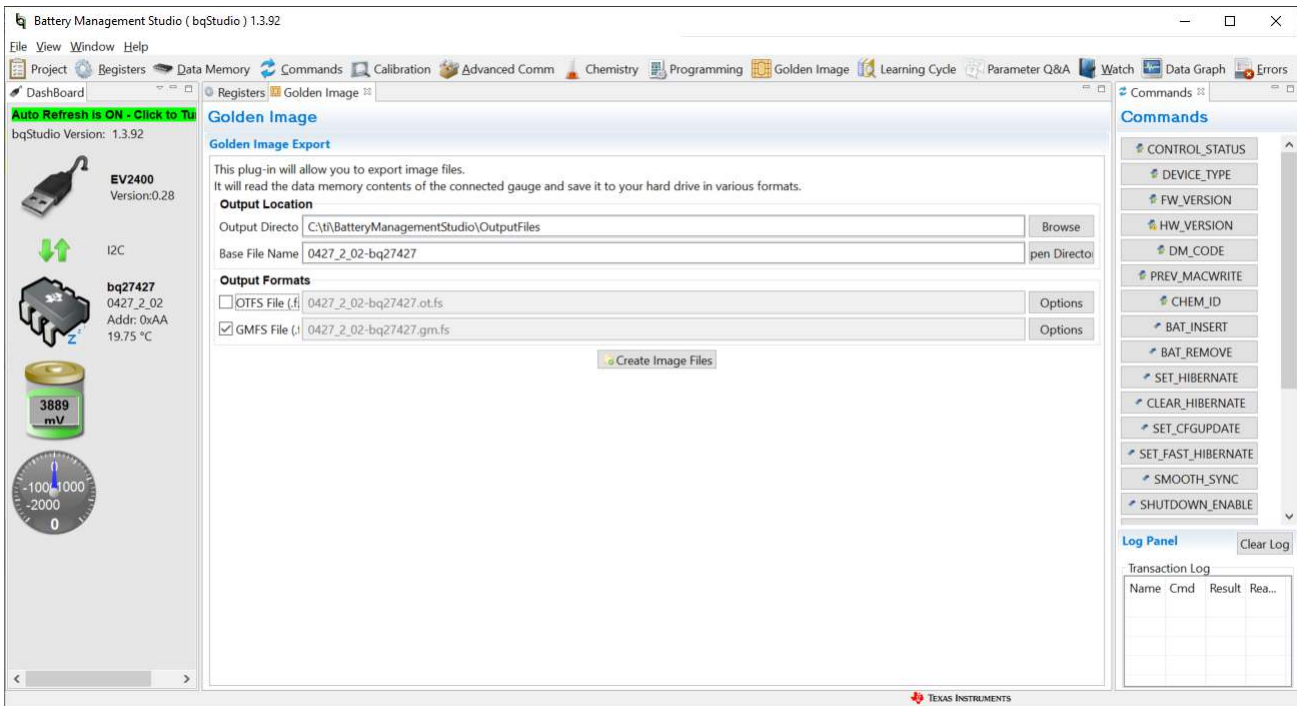

Figure 9-3. Golden Image Output Screen

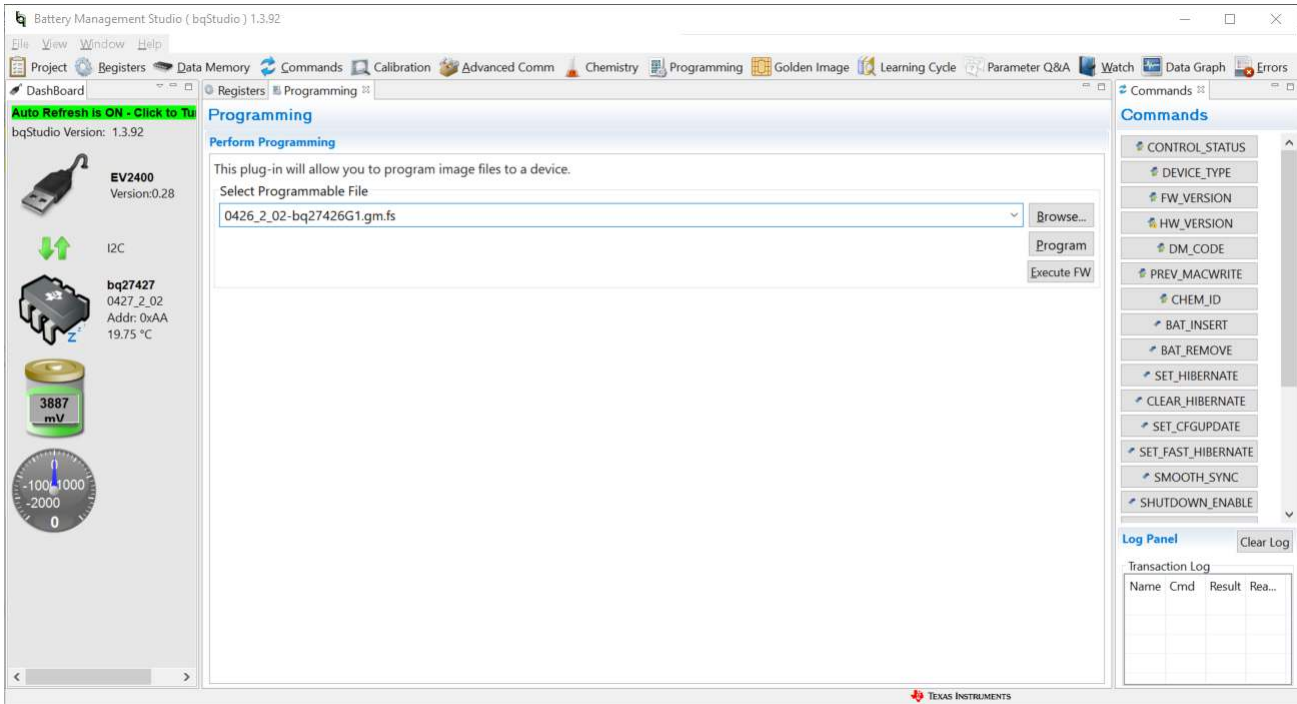

Figure 9-4. Gauge Programming Screen

## 10 Related Documentation

[BQ27427 System-Side Impedance Track™ Fuel Gauge with Integrated Sense Resistor data sheet](#)

## 11 Revision History

DATE	REVISION	NOTES
May 2021	*	Initial Release



## IMPORTANT NOTICE AND DISCLAIMER

TI PROVIDES TECHNICAL AND RELIABILITY DATA (INCLUDING DATA SHEETS), DESIGN RESOURCES (INCLUDING REFERENCE DESIGNS), APPLICATION OR OTHER DESIGN ADVICE, WEB TOOLS, SAFETY INFORMATION, AND OTHER RESOURCES "AS IS" AND WITH ALL FAULTS, AND DISCLAIMS ALL WARRANTIES, EXPRESS AND IMPLIED, INCLUDING WITHOUT LIMITATION ANY IMPLIED WARRANTIES OF MERCHANTABILITY, FITNESS FOR A PARTICULAR PURPOSE OR NON-INFRINGEMENT OF THIRD PARTY INTELLECTUAL PROPERTY RIGHTS.

These resources are intended for skilled developers designing with TI products. You are solely responsible for (1) selecting the appropriate TI products for your application, (2) designing, validating and testing your application, and (3) ensuring your application meets applicable standards, and any other safety, security, regulatory or other requirements.

These resources are subject to change without notice. TI grants you permission to use these resources only for development of an application that uses the TI products described in the resource. Other reproduction and display of these resources is prohibited. No license is granted to any other TI intellectual property right or to any third party intellectual property right. TI disclaims responsibility for, and you will fully indemnify TI and its representatives against, any claims, damages, costs, losses, and liabilities arising out of your use of these resources.

TI's products are provided subject to [TI's Terms of Sale](#) or other applicable terms available either on [ti.com](http://ti.com) or provided in conjunction with such TI products. TI's provision of these resources does not expand or otherwise alter TI's applicable warranties or warranty disclaimers for TI products.

TI objects to and rejects any additional or different terms you may have proposed.

Mailing Address: Texas Instruments, Post Office Box 655303, Dallas, Texas 75265  
Copyright © 2022, Texas Instruments Incorporated