

8 7 6 5 4 3 2 1

NOTES:

- MOUNTING: Mounts in a $\phi .562 \pm .002$ [$\phi 16.56\text{mm} \pm .05$] panel hole on $.750$ [19.05mm] centers. Panel thickness $.031$ [$.8\text{mm}$] to $.187$ [4.75mm]. Panel hole should be deburred, but not chamfered.
- ASSEMBLY: Insert lens through panel hole, slide lock washer onto lens barrel and twist on retaining ring. PCB mounted LEDs slide into lens when the panel cover is closed or the PCB card is inserted into the case.
- MATERIAL: Lens-Polycarbonate, UL 94-V2
Lock Washer- FH Steel, Nickel plate
Retaining ring - Thermoplastic, U.L. 94 V0 Rated
- U.S. & Foreign Pat. Issued & Pend.

REVISIONS				
ECN#	REV.	DESCRIPTION	DATE	INITIALS
	001	REVISED PER EC R111009AZ01	4-23-10	SMU

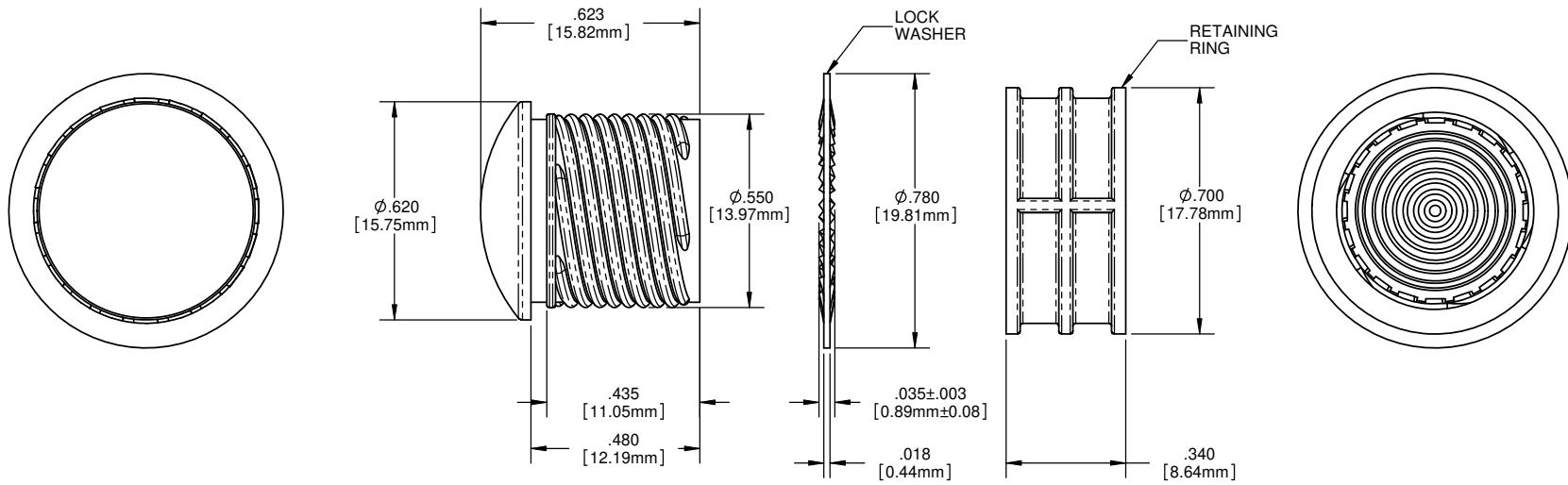
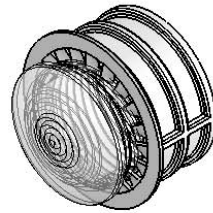

ORDERING CODE : HMC 461 XXX

MODEL

LENS COLOR	
RTP	RED TRANSPARENT
ATP	AMBER TRANSPARENT
GTP	GREEN TRANSPARENT
BTP	BLUE TRANSPARENT
YTP	YELLOW TRANSPARENT
CTP	CLEAR TRANSPARENT

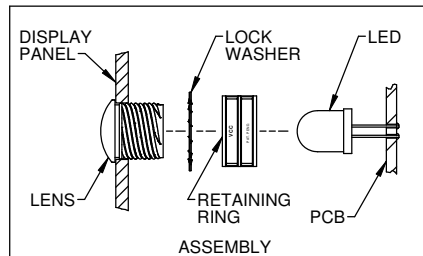

UNLESS OTHERWISE SPECIFIED DIMENSIONS ARE IN INCHES		MATERIAL		SEE NOTES		VISUAL COMMUNICATIONS COMPANY, INC. 190 Bosstick Boulevard, Suite 101 San Marcos, CA 92069 USA Phone (760) 560-1300 Fax (760) 560-1301 email vccsales@vccsite.com	
ANGLES	DECIMALS	FINISH		SEE NOTES		TITLE: 10MM ROUND STANDARD THREADED FRESNEL LENS WITH SEAL	
$\pm 1'$	$\times \pm .020$	BREAK ALL CORNERS AND SHARP EDGES 90° MIN		APPROVAL		DATE	SIZE
	XXX $\pm .010$	THIRD ANGLE PROJECTION		SMU	4-23-10	B	DWG. NO.
	XXX $\pm .005$	THE INFORMATION CONTAINED IN THIS DRAWING IS THE SOLE PROPERTY OF VISUAL COMMUNICATIONS COMPANY, INC. REPRODUCTION IN PART OR AS A WHOLE WITHOUT THE WRITTEN CONSENT OF VISUAL COMMUNICATIONS COMPANY, INC. IS PROHIBITED.		DZ	4-23-10	HMC 461 XXX	REV
DO NOT SCALE DRAWING				SCALE: 4:1		SHEET 1 OF 1	

8 7 6 5 4 3 2 1