

## 30mA, 45V Schottky Barrier Diode

### FEATURES

- Low reverse current, high reliability
- Surface device type mounting
- High temperature soldering guaranteed : 260°C/10s
- Moisture sensitivity level: level 1, per J-STD-020
- RoHS Compliant
- Halogen-free according to IEC 61249-2-21

### APPLICATIONS

- General-purpose switching and amplification

### MECHANICAL DATA

- Case: SOT-323
- Terminal : Matte tin plated, lead free, solderable per MIL-STD-202, method 208 guaranteed
- Weight: 5.00mg (approximately)

KEY PARAMETERS		
PARAMETER	VALUE	UNIT
$I_F$	30	mA
$V_{RRM}$	45	V
$I_{FSM}$	200	mA
$T_{J\ MAX}$	125	°C
Package	SOT-323	



SOT-323

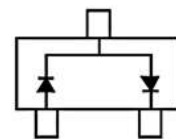

### ABSOLUTE MAXIMUM RATINGS ( $T_A = 25^\circ\text{C}$ unless otherwise noted)

PARAMETER	SYMBOL	VALUE	UNIT
Repetitive peak reverse voltage	$V_{RRM}$	45	V
Reverse Voltage	$V_R$	40	V
Forward current	$I_F$	30	mA
Non-Repetitive peak forward surge current (t = 8.3ms)	$I_{FSM}$	200	mA
Junction temperature	$T_J$	125	°C
Storage temperature	$T_{STG}$	-55 to +125	°C

**THERMAL PERFORMANCE**

PARAMETER	SYMBOL	TYP	UNIT
Junction-to-ambient thermal resistance	$R_{\theta JA}$	500	°C/W

**ELECTRICAL SPECIFICATIONS** ( $T_A = 25^\circ\text{C}$  unless otherwise noted)

PARAMETER	CONDITIONS	SYMBOL	MIN	TYP	MAX	UNIT
Reverse Breakdown Voltage	$I_R = 10\mu\text{A}$	$V_{BR}$	45	-	-	V
Forward Voltage	$I_F = 1\text{mA}$	$V_F$	-	-	370	mV
Reverse current	$V_R = 10\text{V}$	$I_R$	-	-	1	$\mu\text{A}$
Junction capacitance	$V_R = 1\text{V}, f = 1.0\text{MHz}$	$C_J$	-	2	-	pF

**ORDERING AND MARKING INFORMATION**

ORDERING CODE	MARKING	PACKAGE	PACKING
RB706F-40 RFG	ZA	SOT-323	3K / 7" Reel

**CHARACTERISTICS CURVES**

( $T_A = 25^\circ\text{C}$  unless otherwise noted)

**Fig.1  $V_F - I_F$  Characteristics**

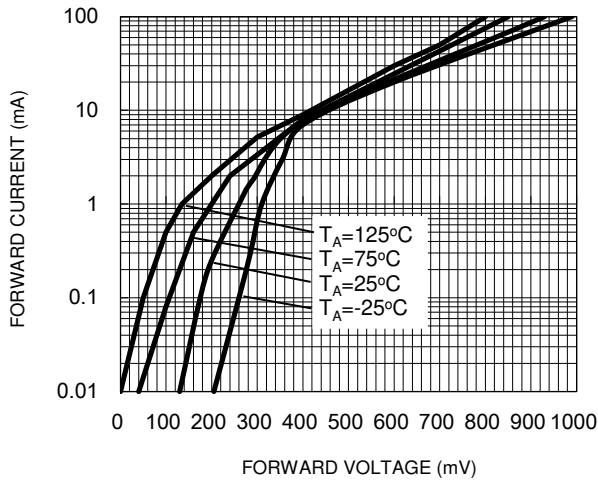

**Fig.2  $V_R - I_R$  Characteristics**

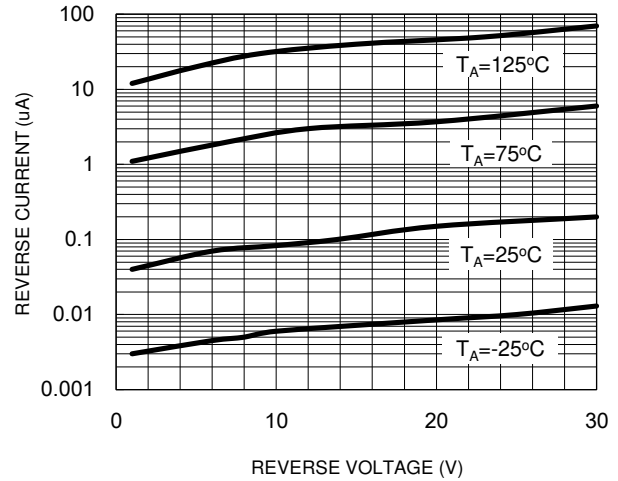

**Fig.3  $V_R - C_t$  Characteristics**

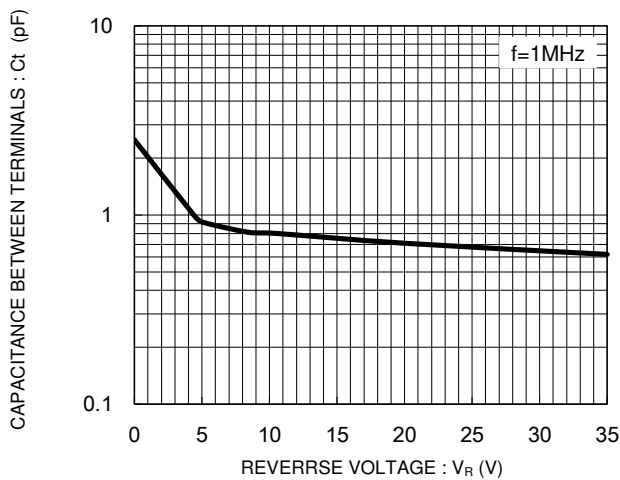

**Fig.4  $I_{FSM}$  Cycle Characteristics**

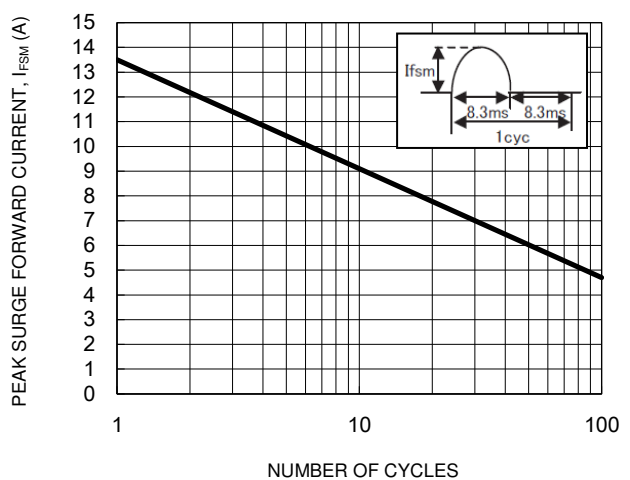

**Fig.5  $I_{FSM} - t$  Characteristics**

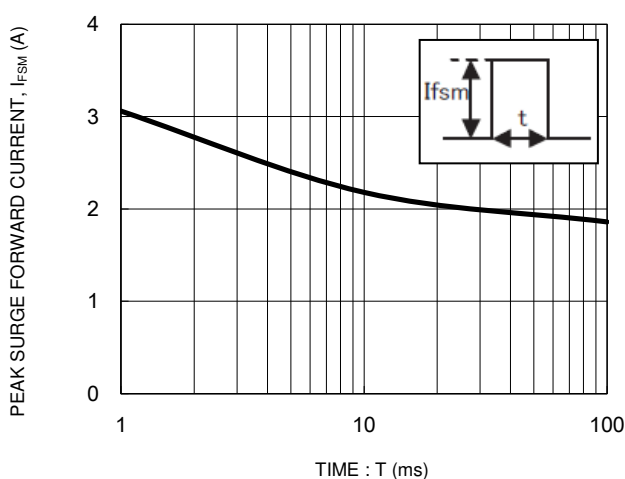

**Fig.6  $R_{th} - t$  Characteristics**

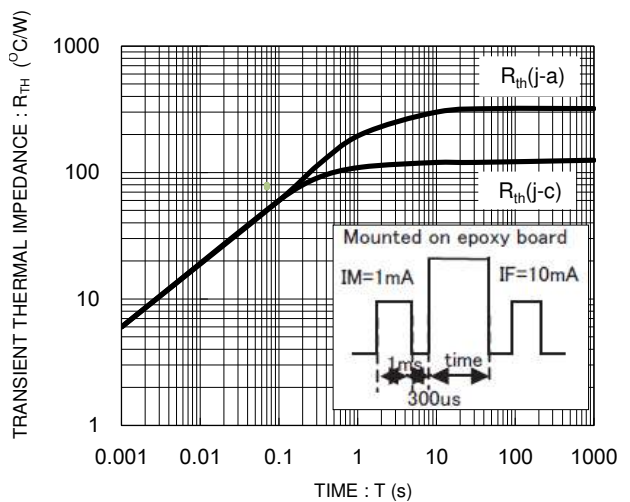

**CHARACTERISTICS CURVES**

( $T_A = 25^\circ\text{C}$  unless otherwise noted)

**Fig.7  $I_o - P_F$  Characteristics**

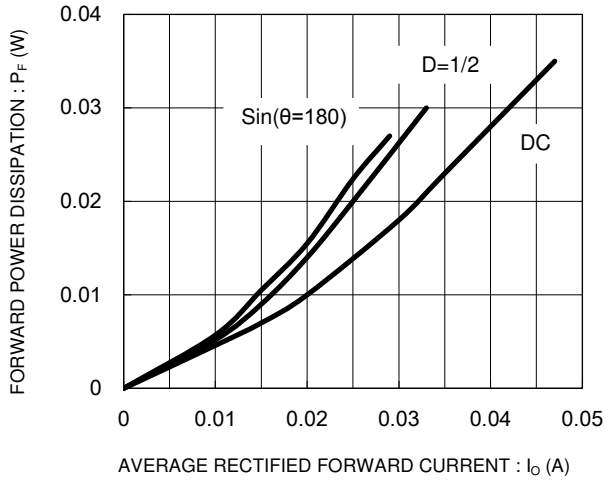

**Fig.8  $V_R - P_R$  Characteristics**

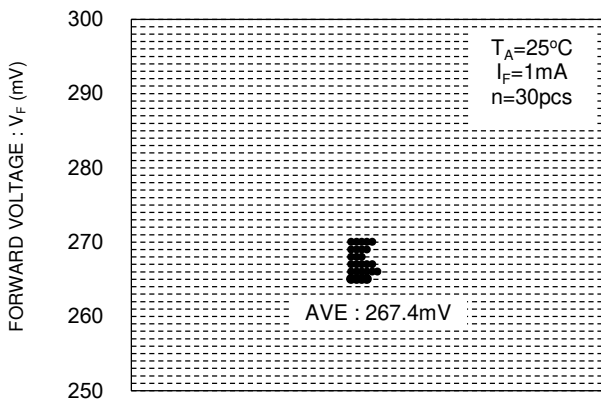
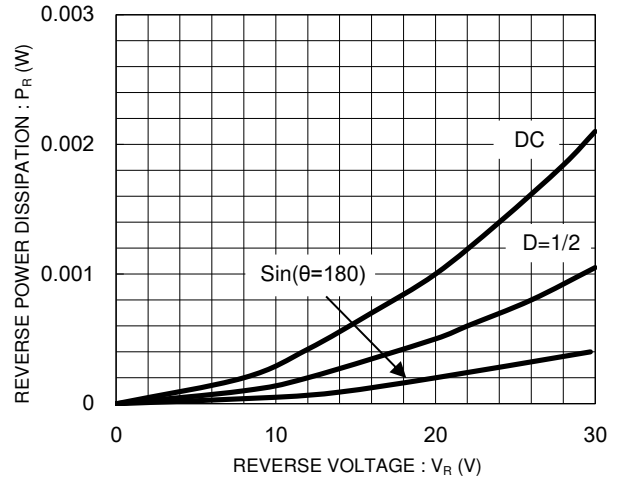

$V_F$  DISPERSION MAP

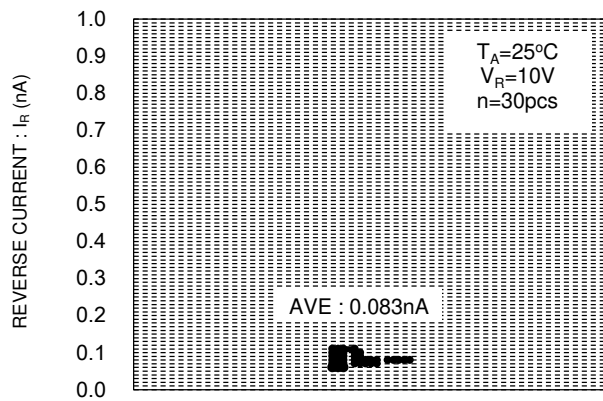

$I_R$  DISPERSION MAP

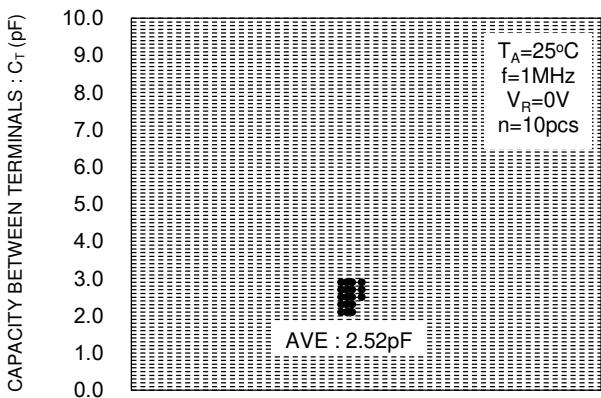

$C_T$  DISPERSION MAP

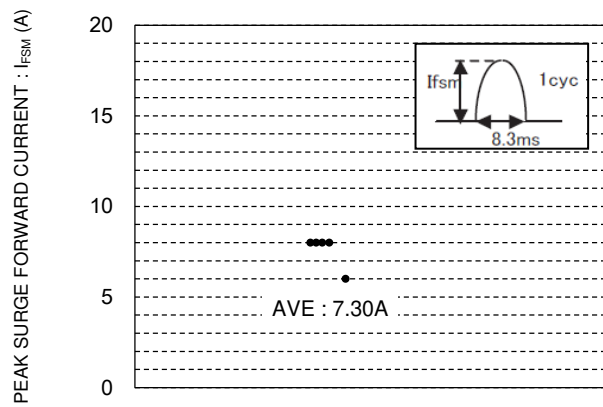

$I_{FSM}$  DISPERSION MAP

**PACKAGE OUTLINE DIMENSIONS**

SOT-323

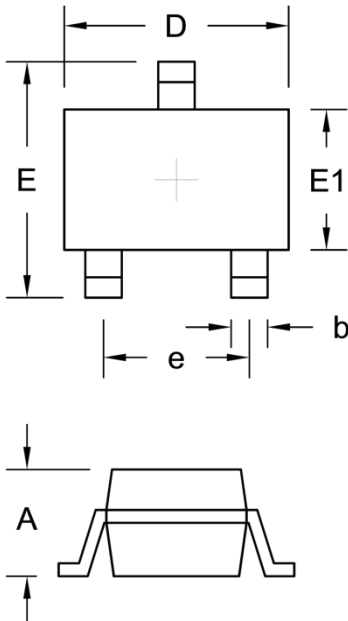

DIM.	Unit (mm)		Unit (inch)	
	Min.	Max.	Min.	Max.
A	0.80	1.10	0.031	0.043
b	0.25	0.40	0.010	0.016
D	1.80	2.20	0.071	0.087
E	1.80	2.40	0.071	0.094
E1	1.15	1.35	0.045	0.053
e	1.30 (TYP)		0.051 (TYP)	

**SUGGESTED PAD LAYOUT**

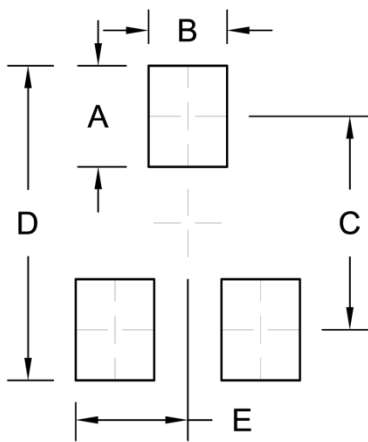

Symbol	Unit (mm)	Unit (inch)
A	0.90	0.035
B	0.70	0.028
C	1.90	0.075
D	2.80	0.110
E	1.00	0.039

## **Notice**

Specifications of the products displayed herein are subject to change without notice. TSC or anyone on its behalf, assumes no responsibility or liability for any errors or inaccuracies.

Purchasers are solely responsible for the choice, selection, and use of TSC products and TSC assumes no liability for application assistance or the design of Purchasers' products.

Information contained herein is intended to provide a product description only. No license, express or implied, to any intellectual property rights is granted by this document. Except as provided in TSC's terms and conditions of sale for such products, TSC assumes no liability whatsoever, and disclaims any express or implied warranty, relating to sale and/or use of TSC products including liability or warranties relating to fitness for a particular purpose, merchantability, or infringement of any patent, copyright, or other intellectual property right.

The products shown herein are not designed for use in medical, life-saving, or life-sustaining applications. Customers using or selling these products for use in such applications do so at their own risk and agree to fully indemnify TSC for any damages resulting from such improper use or sale.