

### Rectifier Diode ISOPLUS220™

$V_{RRM} = 800 - 1200 \text{ V}$   
 $I_{F(AV)M} = 30 \text{ A}$

#### Electrically Isolated Back Surface

$V_{RSM}$ V	$V_{RRM}$ V	Type
900	800	DSI 30-08AC
1300	1200	DSI 30-12AC



ISOPLUS 220™

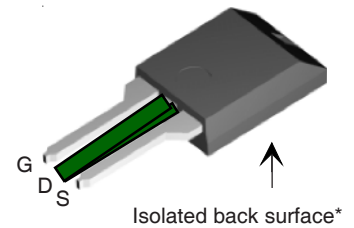

#### Preliminary Data Sheet

Symbol	Conditions	Maximum Ratings	
$I_{FRMS}$	$T_C = 95^\circ\text{C}; 180^\circ$ sine (RMS current limited)	60	A
$I_{FAV}$		30	A
$I_{FSM}$	$T_{VJ} = 45^\circ\text{C}; t = 10 \text{ ms}$ (50 Hz), sine	200	A
	$V_R = 0 \text{ V}; t = 8.3 \text{ ms}$ (60 Hz), sine	210	A
$I^2t$	$T_{VJ} = 150^\circ\text{C}; t = 10 \text{ ms}$ (50 Hz), sine	175	A
	$V_R = 0 \text{ V}; t = 8.3 \text{ ms}$ (60 Hz), sine	185	A
$I^2t$	$T_{VJ} = 45^\circ\text{C}; t = 10 \text{ ms}$ (50 Hz), sine	200	A <sup>2</sup> s
	$V_R = 0 \text{ V}; t = 8.3 \text{ ms}$ (60 Hz), sine	185	A <sup>2</sup> s
$T_{VJ}$	$T_{VJ} = 150^\circ\text{C}; t = 10 \text{ ms}$ (50 Hz), sine	155	A <sup>2</sup> s
	$V_R = 0 \text{ V}; t = 8.3 \text{ ms}$ (60 Hz), sine	145	A <sup>2</sup> s
$T_{VJ}$		-55...+150	°C
$T_{VJM}$		150	°C
$T_{stg}$		-55...+150	°C
$T_L$	1.6 mm (0.062 in.) from case for 10 s	260	°C
$V_{ISOL}$	50/60 Hz RMS; $I_{ISOL} \leq 1 \text{ mA}$	2500	V~
$F_C$	Mounting Force	11...65 / 2.4...11	N / lb
Weight	typical	2	g

#### Features

- Silicon chip on Direct-Copper-Bond substrate
- High power dissipation
- Isolated mounting surface
- 2500V electrical isolation
- Low cathode to tab capacitance(15pF typical)
- International standard package
- Epoxy meets UL 94V-0

#### ISOPLUS220 Outline (2 leads)

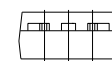
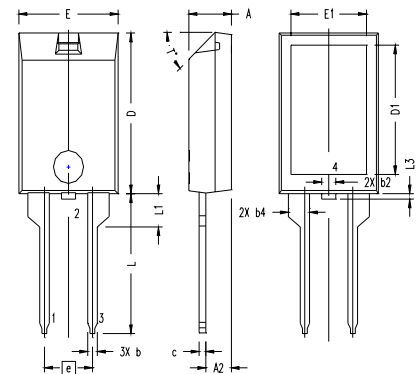

SYM	INCHES		MILLIMETERS	
	MIN	MAX	MIN	MAX
A	.157	.197	4.00	5.00
A2	.098	.118	2.50	3.00
b	.035	.051	0.90	1.30
b2	.049	.065	1.25	1.65
b4	.093	.100	2.35	2.55
c	.028	.039	0.70	1.00
D	.591	.630	15.00	16.00
D1	.472	.512	12.00	13.00
E	.394	.433	10.00	11.00
E1	.295	.335	7.50	8.50
e	.200 BASIC		5.08 BASIC	
L	.512	.571	13.00	14.50
L1	.118	.138	3.00	3.50
L3	.000	.059	0.00	1.50
T*			42.5°	47.5°

NOTE:  
1. Bottom heatsink (Pin 4) is electrically isolated from Pin 1, 2, or 3.

Symbol	Conditions	Characteristic Values	
		typ.	max.
$I_R$	$T_{VJ} = 25^\circ\text{C}; V_R = V_{RRM}$ $T_{VJ} = T_{VJM}; V_R = V_{RRM}$	0.05	mA
		1.5	mA
$V_F$	$I_F = 45 \text{ A}; T_{VJ} = 25^\circ\text{C}$	1.45	V
$V_{TO}$	For power loss calculations only	0.80	V
$r_T$	$T_{VJ} = T_{VJM}$	15	mΩ
$R_{thJC}$	0.6	1.1	K/W
$R_{thCH}$		K/W	

Note: See DSI 30..A data sheet for electrical characteristic curves.

IXYS reserves the right to change limits, conditions and dimensions.