

ASAIR<sup>®</sup>

# Mass Flow Meter

Product Manual

AFM3000



## Features

- Low pressure drop
- Flow range: +/- 200 slm (bidirectional)
- Accuracy 1.5% m.v. (typical)
- Very fast update time
- Fully calibrated & temperature compensated
- Low zero drift

## Product Summary

The AFM3000 sensor is Aosong's digital flow meter designed specifically for ventilator applications. It measures the flow rate of air, oxygen and other non-aggressive gases with superb accuracy. A special design of the flow channel results in the very low pressure drop through the flow body of the sensor making it extremely suitable for very demanding applications, such as medical ventilation and respiratory applications.

The AFM3000 operates from a 5V supply voltage and features a digital I<sup>2</sup>C interface. The measurement results are internally linearized and temperature compensated.

The outstanding performance of this sensor is based on Aosong's sensor technology, which combines a thermal sensor chip and a high-performance integrated

24-bit AD acquisition CMOS microprocessor. The flow rate of the gas is measured by a thermal sensor element which assures very fast signal processing time and bidirectional measurement with best-in-class accuracy.

## Applications

Medical, Process automation, Burner control, Fuel cell control, Spectroscopy, Environment monitoring, Laboratory

## OEM industry customization and solutions

Our company is committed to research and development of various sensors, with professional R&D laboratories and equipment, supporting a variety of simulation environment experimental conditions, to create high-quality product production and inspection process. The AFM3000 is one of the chips independently developed and manufactured by our company. The flow range and independent flow channel structure can be customized according to the application site and customer needs. Aosong professionally provide customers with complete application solutions

## Content

1. Sensor performance.....	- 3 -
2. Sensor electrical characteristics .....	- 4 -
3. Sensor communication .....	- 4 -
3.1 I <sup>2</sup> C communication interface characteristics and timing .....	- 5 -
3.2 Sensor data collection .....	- 5 -
3.3 Read device ID .....	- 6 -
3.4 Reset command.....	- 6 -
3.5 AFM3000 I <sup>2</sup> C command definition.....	- 6 -
3.6 AFM3000 CRC calculation routine .....	- 7 -
3.7 Flow conversion formula .....	- 7 -
4. Pin definition .....	- 8 -
5. Typical circuit .....	- 8 -
5.1 Typical circuit connection .....	- 8 -
6. Dimension (unit:mm) .....	- 9 -
6.1 AFM3000 dimension .....	- 9 -
6.2 Machinery parts .....	- 9 -
7. Model list .....	- 10 -
8. Precautions .....	- 10 -
8.1 Calibration direction .....	- 10 -
8.2 Inlet flow conditions.....	- 10 -
8.3 Temperature compensation .....	- 10 -
8.4 Processing .....	- 11 -
8.5 ESD.....	- 11 -
9. Accuracy statement .....	- 11 -
10. Important notices .....	- 11 -

# 1. Sensor performance

Table 1: AFM3000 performance table of accuracy conditions<sup>1</sup>

Parameter	Condition	Value		Unit
Flow Ranges	Air/N <sub>2</sub> /O <sub>2</sub>	-200~+200 <sup>2</sup>		slm <sup>3</sup>
		Max.	Typ.	
Accuracy <sup>4, 5, 6, 7</sup>	span	±2.5	±1.5	% m.v.
	offset	±0.1	±0.05	slm
Repeatability <sup>4, 7</sup>	span	±1	±0.5	% m.v.
	offset	±0.05	±0.02	slm
Noise Level <sup>4, 7</sup>	span	±1	±0.5	% m.v.
	offset	±0.1	±0.05	slm
Accuracy Shift Due to Temperature Variation <sup>8</sup>	span	±0.75	±0.25	% m.v./10°C
	offset	±0.0	±0.0	slm
Position sensitivity	non-horizontal position	<0.05		slm
Pressure Drop	@60slm	<100/<0.4		Pa/inH <sub>2</sub> O
	@200slm	<600/<2.4		

Table2: Media compatibility and materials

Parameter	Value
Calibration	Air, N <sub>2</sub> , O <sub>2</sub>
Media Compatibility	Air (non-condensing), N <sub>2</sub> , O <sub>2</sub> , non- aggressive gases
Wetted Materials	PPE+PS blend (medical grade: biocompatible; ISO 10993 or USP Class VI), Si, Si <sub>3</sub> N <sub>4</sub> , SiO <sub>x</sub> , Gold, Epoxy, Polyurethane, stainless steel (annealed)
RoHS, REACH	RoHS and REACH compliant
Sensor Weight with Cap	<25 gram

1 Unless otherwise noted, all sensor specifications are valid at 25°C with Vdd = 5V and absolute pressure = 966 mbar.

2 The range of AFM3000-200 models is ± 200slm, other models are shown in Table 10.

3 In standard liter per minute at 20°C and 1013 mbar

4 With ideal inlet and outlet conditions, at VDD = 5V, 25°C, absolute pressure = 966 mbar

5 Including offset, non-linearity, hysteresis

6 Sensor position horizontal (see Section 8.1)

7 Span or offset value, whichever is larger

8 Shift due to temperature variation compared to calibration temperature

## 2. Sensor electrical characteristics

Electrical characteristics, such as sleep power consumption, measurement power consumption, etc., all depend on the power supply. The table 3 details the electrical characteristics of AFM3000. If not marked, it means that the power supply voltage is 5V.

Table3: AFM3000 electrical characteristics parameter table

Parameter	Condition	MIN	TYP	MAX	Unit
Interface			I <sup>2</sup> C		
Supply Voltage	VDD	4.75	5	5.25	V
I <sup>2</sup> C Communication Level	High	4	-	VDD	V
	Low	GND	-	0.8	V
Sampling Time			10		ms
Power Consumption	Measure		7.5	10	mA
I <sup>2</sup> C Communication Rate			100	400	Kb/s
Operating Temperature		0		+50	°C
Storage Temperature		0		+50	°C
Working pressure range	Absolute	0.7		1.3	bar
Operating Overpressure	Measure		±0.2		bar
Burst Overpressure	Measure		>1		bar
Scale Factor Flow	Air/N <sub>2</sub>		140		1/slm
	O <sub>2</sub>		142.8		
Offset Flow			32000		

## 3. Sensor communication

AFM3000 sensor adopts standard I<sup>2</sup>C communication protocol to adapt to various devices. The protocol uses two data lines: serial data bus (SDA) and serial time bus (SCL). The two internal data lines have been connected with 4.7K pull-up resistors to VDD. Multiple sensor devices can share the bus; but only one host device can appear on the bus. The sensor I2C address is 0x40, the I2C read command is 0x81, and the I2C write command is 0x80.

If the SCL and SDA signal lines are parallel and very close to each other, it may cause signal crosstalk and communication failure. The solution is to place VDD or GND power signals between the two signal lines, separate the signal lines or use shielded cables. Wait. In addition, it is also possible to improve the integrity of signal transmission by reducing the SCL frequency. The sensor needs to be

led out, then a 100nF decoupling capacitor should be added between the positive and negative power supply pins for filtering. This capacitor should be as close as possible to the sensor.

### 3.1 I<sup>2</sup>C communication interface characteristics and timing

In the I2C bus, the AFM3000 sensor as a slave device supports a communication rate up to 400kHz bit rate. When the host sends a start signal (low level), the sensor starts to communicate. When the host sends a stop signal (high level), when the communication ends, the start and end signals are only valid when SCL is high.

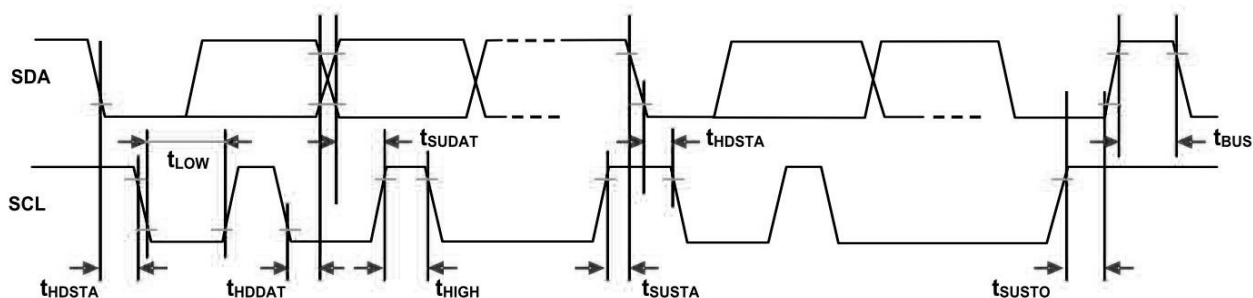

Fig1: I<sup>2</sup>C Timing

Table4: I<sup>2</sup>C parameter

Parameter	Condition	MIN	TYP	MAX	Unit
I <sup>2</sup> C Clock Frequency	f <sub>SCL</sub>	10		400	KHz
Start Signal Time	t <sub>HDSTA</sub>	0.8			μs
SCL Clock High Width	t <sub>HIGH</sub>	0.6			μs
SCL Clock Low Width	t <sub>LOW</sub>	0.6			μs
Set Time Relative to SCL Edge Start Condition	t <sub>SUSTA</sub>	0.1			μs
Data Retention Time Relative to SCL SDA Edge	t <sub>HDDAT</sub>	0		0.5	μs
Data Setup Time Relative to SCL SDA Edge	t <sub>SUDAT</sub>	1			μs
Set Time at SCL Stop Condition	t <sub>SUSTO</sub>	0.1			μs
Bus Idle Time Between Stop Condition and Start Condition	t <sub>BUS</sub>	1			μs

### 3.2 Sensor data collection

After the self-test of the AFM3000 sensor, data will be collected in 10 ms cycles. At the end of a measurement cycle, the data output register will be refreshed. Users can collect flow data through flow collection instructions, which are defined as follows:

Table5 Flow collection command description

Command	Condition	Hex code	Position	Definition
Flow Collection	High Command	0x10	Bit15:8	Sensor data high
	Low Command	0x00	Bit7:0	Sensor data low

### 3.3 Read device ID

Each AFM3000 sensor has a unique ID with a length of 32 bits, and the device ID query instruction is defined as follows:

Table6: Device ID query command description

Command	Condition	Hex code	Position	Definition
Device ID query	High Command	0x31	Bit31:24	first byte of the ID number
			Bit23:16	second byte of the ID number
	Low Command	0xAE	Bit15:8	third byte of the ID number
			Bit7:0	fourth byte of the ID number

### 3.4 Reset command

When the user needs to reset the AFM3000 sensor, the software can be reset by sending the following command:

Table7: Reset command description

Command	Condition	Hex code
Reset	High Command	0x20
	Low Command	0x00

### 3.5 AFM3000 I<sup>2</sup>C command definition

Table8: I<sup>2</sup>C protocol frame

reading sensor frame format: host frame format: (SLA+W )+ High byte command + Low byte command +(SLA+R )+delay+ return data +CRC8		
write sensor frame format: host frame format: (SLA+W )+ High byte command+ Low byte command		
<b>Sensor register list:</b>		
Command description	Command (16bit)	Returns the number of bytes
Read traffic	0x1000	2
Read ID number	0x31AE	4
Reset command	0x2000	NA

### 3.6 AFM3000 CRC calculation routine

AFM3000 sensor CRC verification uses CRC8, the initial value is 0X00, the polynomial is 0x131 ( $x^8 + x^5 + x^4 + 1$ ), please see the code below

```

//*****
// Function name: Calc_CRC8
// Features      : CRC8 calculation, initial value: 0x00, polynomial: 0x131(x8 + x5 + x4 +1 )
// Parameter     : u8 *data: CRC check the first number; u8 Num: CRC check data length
// Return        : crc: calculate the value of crc8
//*****
u8 Calc_CRC8(u8 *data, u8 Num)
{
    u8 bit,byte,crc=0x00;
    for(byte=0; byte<Num; byte++)
    {
        crc^=(data[byte]);
        for(bit=8;bit>0;--bit)
        {
            if(crc&0x80) crc=(crc<<1)^0x131;
            else crc=(crc<<1);
        }
    }
    return crc;
}

```

### 3.7 Flow conversion formula

The flow results need to use the following formula to convert the measured value:

$$\text{Flow [slm]} = \frac{\text{Measurements} - \text{Offset}}{\text{Flow Coefficient}}$$

Example: The offset of AFM3000 is 32000, the air flow coefficient is 140, the measured value read by I2C is 33400;

$$\text{Flow [slm]} = \frac{33400 - 32000}{140} = 10 \text{ slm}$$

Please note that the first measurement performed directly after chip initialization is invalid.



## 4. Pin definition

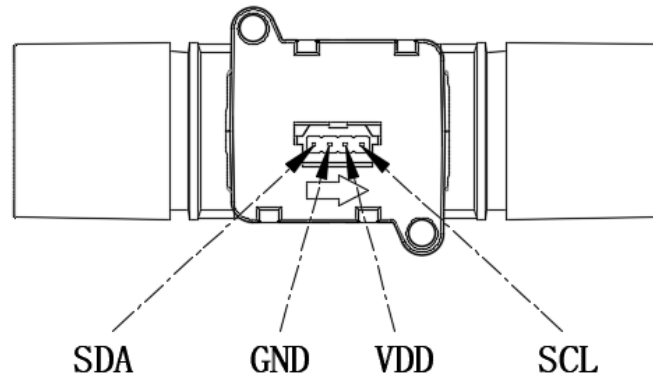

Fig2: Sensor pin layout

Table9: Pin function description

Pin	Condition	Type	Description
1	VDD	+5V	power supply pin
2	SDA	IN/OUT	I <sup>2</sup> C digital communication data pin
3	GND	/	ground
4	SCL	IN	I <sup>2</sup> C digital communication clock pin

## 5. Typical circuit

### 5.1 Typical circuit connection

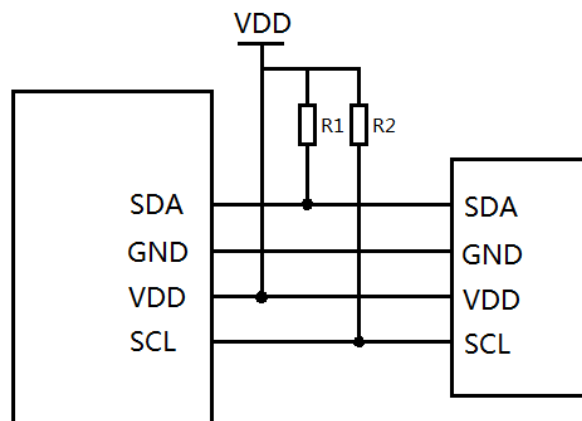

Note: The recommended resistance value of R1 and R2 is 10K

Fig3: Typical circuit diagram

## 6. Dimension (unit:mm)

### 6.1 AFM3000 dimension

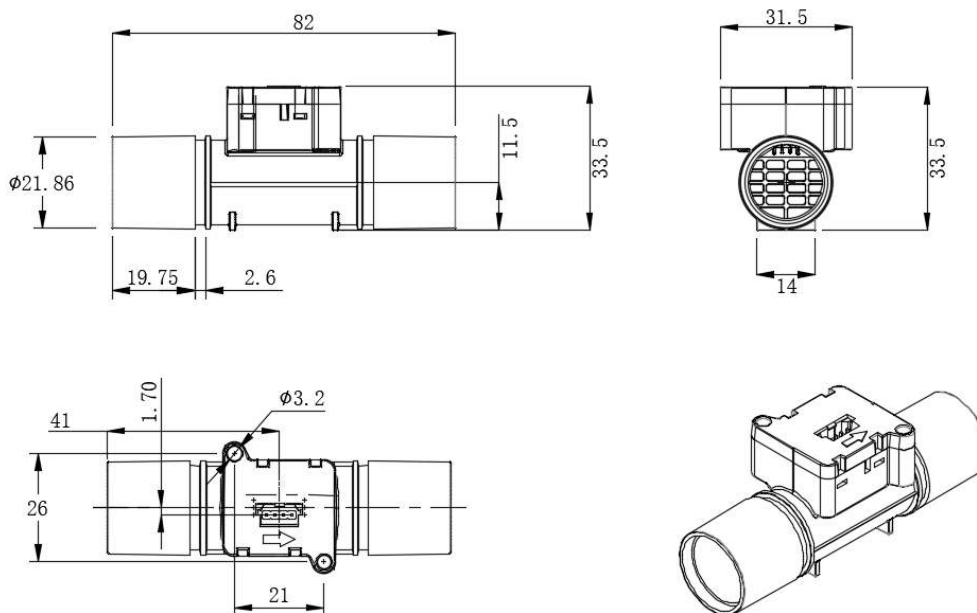
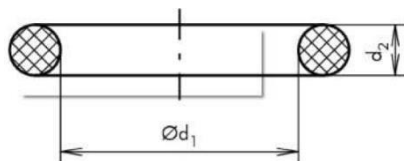

Fig4: Flow sensor dimensions

Note: If the AFM3000 sensor is directly soldered on the PCB, it should not be soldered by reflow soldering or soldering, otherwise the sensor may be damaged. During the soldering process, the sensor port must be protected to prevent the solder from splashing and damaging the sensor

### 6.2 Machinery parts

The accessories of the AFM3000 sensor comply with the international standard ISO5356-1: 2004. Detailed information about this type of connection can be found in the standard description. To minimize the risk of accidental disconnection of the connector, a latched connector can be used, or an O-ring can be inserted into the groove, and a pipe with an inner diameter of 23 mm can be connected to the AFM3000.



$d_1=19\text{mm } d_2=2\text{mm}$

Section of recommend O-ring

## 7. Model list

Table10: model list

Model	Range	Unit
AFM3000-20	0-20	slm
AFM3000-50	0-50	slm
AFM3000-100	0-100	slm
AFM3000-150	0-150	slm
AFM3000-200	0-200	slm

## 8. Precautions

### 8.1 Calibration direction

As shown in the figure below, calibrate the sensor horizontally:

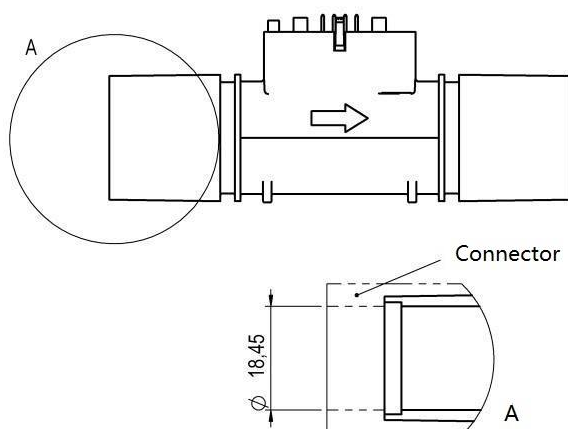

### 8.2 Inlet flow conditions

In order to provide good flow conditions, the inner diameter of the connecting pipe has to be approximately the same as the inner diameter of the AFM3000 main channel. The inlet pipe must be straight and at least 10 cm in length. AFM3000 installed grids at the inlet and outlet of the flow channel to reduce turbulence and improve stability.

### 8.3 Temperature compensation

AFM3000 sensor has digital temperature compensation. The temperature is measured by the on-chip temperature sensor on the chip and then fed back to the sensor processing chip. Therefore, no external temperature compensation is required.

## 8.4 Processing

The AFM3000 sensor is sturdy and shock resistant. However, the accuracy of the high-precision AFM3000 may be reduced due to improper operation. Aosong do not guarantee normal operation in case of improper handling. Note: Avoid any mechanical stress on the solder joints of the sensor during PCB assembly or due to PCB assembly.

## 8.5 ESD

AFM3000 will be exposed to sunlight or strong ultraviolet radiation for a long time, the performance will be reduced, and the casing will be aging.

AFM3000 meet the following anti-static standards:

- AEC-Q-100-002 (4kV HBM)
- AEC-Q-100-003 (200V MM)

Although the sensor meets these specifications, it does not mean that the sensor itself is compatible with ESD. When installing the sensor, please place it in an anti-static tray to prevent electrostatic discharge. In order to avoid damage to the sensor, personnel need to wear an electrostatic bracelet or wear insulated gloves before touching the sensor.

## 9. Accuracy statement

The AFM3000 sensor is strictly calibrated in accordance with the AS-WI-RD3370 precision measurement guidance document. The performance of the sensor under other test conditions is not guaranteed and cannot be used as part of the sensor performance. Especially for the specific occasions requested by users, no commitment is made.

## 10. Important notices

1. Do not use this product as safety or emergency stop devices or in any other application where failure of the product could result in personal injury (including death). Do not use this product for applications other than its intended and authorized use. Before installing, handling, using or servicing this product

2. Please consult the datasheet and application notes. Failure to comply with these instructions could result in death or serious injury.

3. Based on the information provided by our suppliers, the materials used in this product and raw materials are harmless to the human body. Aosong has not verified this information through third-party analysis.

4. For any application using this product, expressly reject any and all responsibilities, including but not limited to consequential or incidental compensation.