

“Rail-to-Rail Plus™”, 1% RON Flatness, 0.8V to 5.25V Analog 8-Channel Switch/Multiplexer

## FEATURES

- 8-Channel Switch/Multiplexer
- Low Supply Voltage Operation: 0.8V to 5.25V
- On-Resistance of 80Ω
- Rail-to-Rail Plus™ input/output voltages can exceed the supply rails
- Fully Assembled and Tested
- 2in x 2in 4-layer circuit board

## COMPONENT LIST

DESIGNATION	QTY	DESCRIPTION
C1	1	10pF ±10% capacitor (0603)
C2	1	1µF ±10% capacitor (0603)
R1-R8	8	100kΩ ± 1% (0603)
R9	1	1kΩ ± 1% (0603)
U1	1	TS4100
VDD, COM, GND, 0-7	12	Test points
J1, INH, A, B, C	5	Jumper

## DESCRIPTION

The demo board for the TS4100 is a completely assembled and tested circuit board that can be used for evaluating the analog 8-channel switch/multiplexer. This switch/multiplexer is unique as it can operate at a supply voltage as low as 0.8V while accepting an input signal swing above the supply voltage up to 5.25V (“Rail-to-Rail Plus™”). The on-resistance variation over the entire signal swing range is less than 1% exhibiting excellent linearity and consistency in dynamic and measurement applications.

The board is configured for testing all 8 channels, NO0-NO7, with a DC input voltage derived from VDD. Jumper INH is available to turn all switches OFF. Jumper A, B, and C is available to select a channel.

The TS4100 is fully specified over the -40°C to +85°C temperature range and is available in a low-profile, thermally-enhanced 16-pin 3x3mm TQFN package with an exposed back-side paddle. For best performance, solder exposed back-side paddle to PCB ground.

Product datasheet and additional documentation can be found on the factory web site at [www.touchstonesemi.com](http://www.touchstonesemi.com).

## ORDERING INFORMATION

Order Number	Description
TS4100DB	TS4100 Demo Board



Figure 1. TS4100 Demo Board (Top View)

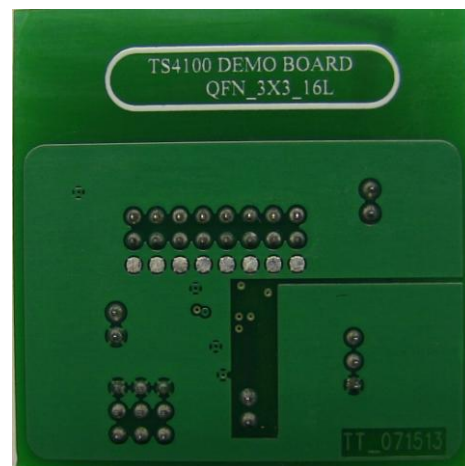

Figure 2. TS4100 Demo Board (Bottom View)

## DESCRIPTION

The TS4100 demo board is configured with a COM output resistor and capacitor load of 1k $\Omega$  and 10pF. The TS4100 operates at a supply voltage range of 0.8V to 5.25V and an analog input/output “Rail-to-Rail Plus<sup>TM</sup>” range of 0V to 5.25V.

The TS4100 can be tested with an on-board DC input signal or an external AC input signal. The on-board voltage is generated via a voltage divider circuit. The complete demo board circuit is shown in Figure 3. To select a channel or turn OFF all channels, jumper A, B, C, and INH can be set according to Table 1.

INH	ADDRESS BITS			COM Output
	A	B	C	
1	X	X	X	GND
0	0	0	0	NO0
0	0	0	1	NO1
0	0	1	0	NO2
0	0	1	1	NO3
0	1	0	0	NO4
0	1	0	1	NO5
0	1	1	0	NO6
0	1	1	1	NO7

**Table 1:** Jumper A, B, C, and INH Setting

## QUICK START PROCEDURE

### Required Equipment

- TS4100 Demo Board
- DC Power Supply
- Digital Ammeter, an HP34410A or equivalent
- Digital Voltmeter, an HP34410A or equivalent

To evaluate the TS4100 analog 8-channel switch/multiplexer, the following steps are to be performed:

1. Before connecting the DC power supply to the demo board, turn on the power supply, set the DC voltage to 1.5V, and then turn it off.
2. Connect the DC power supply positive terminal to the test point labeled VDD. Connect the negative terminal of the DC power supply to the test point labeled GND.

3. Set jumper A, B, and C to a HIGH state by moving the jumper position from LO to HI.
4. Find the 16-pin header on the board labeled INPUTS. Place a jumper on the two-pin header labeled 7. This sets a DC voltage to channel NO7.
5. To monitor the COM output signal, connect the positive terminal of the digital voltmeter to the test point labeled as COM and the negative terminal to the adjacent test point labeled as GND.
6. Turn on the power supply and check that the digital voltmeter is reading an output voltage of approximately 1.39V. With an output voltage of 1.39V across an output resistor value of 1k $\Omega$ , the resulting load current is 1.39mA. This yields an on-resistance of approximately 79 $\Omega$ , which is well within the datasheet on-resistance specification.
7. To test a different channel, refer to Table 1 and make the appropriate changes to jumper A, B, and C.

### MEASURING THE SUPPLY CURRENT

8. Turn off the power supply and connect a digital ammeter in series with the power supply.
9. Remove the positive terminal of the digital voltmeter from the COM output test point.
10. Remove jumper J1 and the jumper on the selected channel.
11. Turn on the power supply and check that the digital ammeter is reading a supply current less than 765nA.

### APPLYING AN EXTERNAL INPUT SIGNAL

12. Turn off the power supply.
13. Connect the positive terminal of a DC power supply or an AC signal generator to the test point labeled “0” on the 16-pin header labeled INPUTS. Connect the negative terminal to a test point labeled GND. For an AC input signal, make sure the maximum input voltage level is less than 5.25V and the minimum input voltage level is greater than 0V. For a DC input signal, make sure the input voltage is less than 5.25V and greater than 0V.

14. Check that the AC input signal levels are within the levels specified in the previous step with an oscilloscope. Check a DC input voltage level with a voltmeter.
15. With an applied DC input signal, connect the positive terminal of the digital voltmeter to the test point labeled as COM and the negative terminal to the adjacent test point labeled as GND. With an applied AC input signal, connect the signal terminal of an oscilloscope probe to the test point labeled as COM and the ground terminal to the adjacent test point labeled as GND.
16. Turn on the power supply.

17. Turn on the DC power supply input signal or AC signal generator. For a DC input signal, monitor the digital voltmeter. For an AC input signal, monitor the oscilloscope.

### TURN OFF ALL SWITCHES

18. Turn off the power supply.
19. Remove the jumper between INH and LO and connect it between INH and HI. Refer to Table 1.

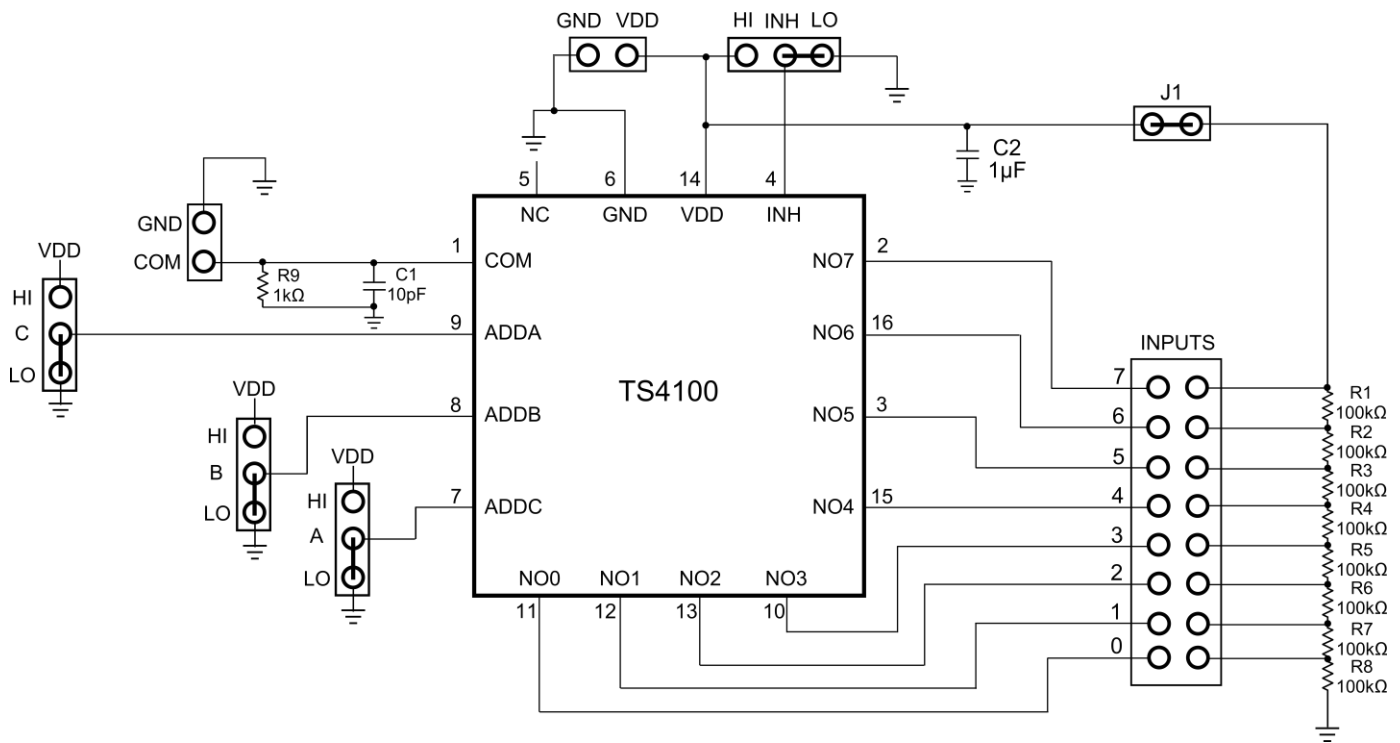

Figure 3. TS4100 Demo Board Circuit

# TS4100 Demo Board

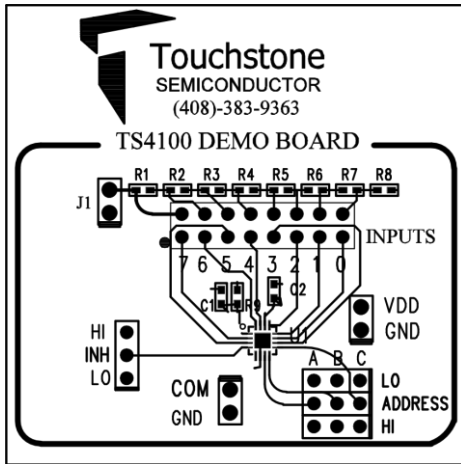

Figure 4. Top Layer View #1

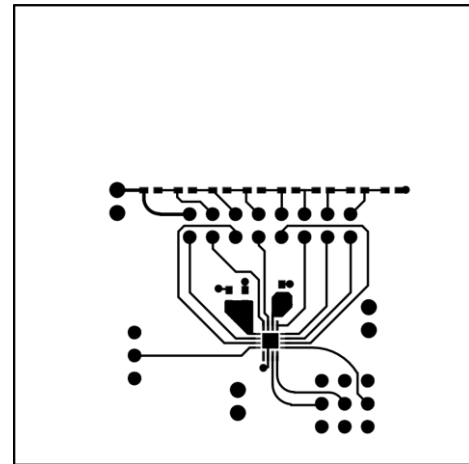

Figure 5. Top Layer View #2

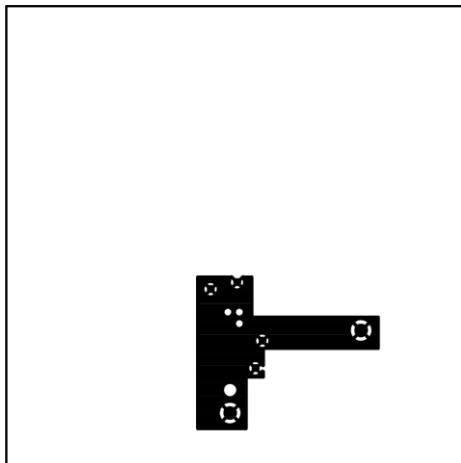

Figure 6. Layer 2

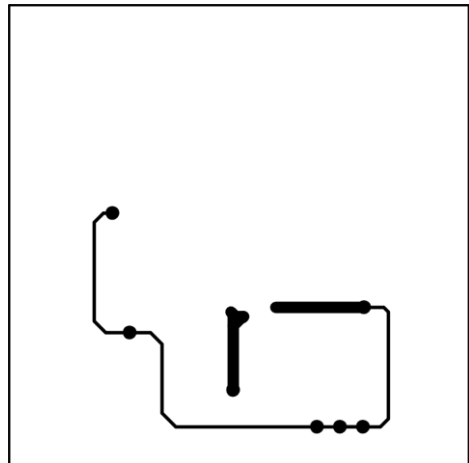

Figure 7. Layer 3

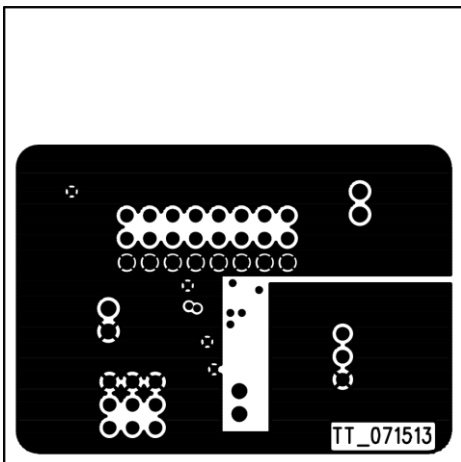

Figure 8. Bottom Layer 4 View #1

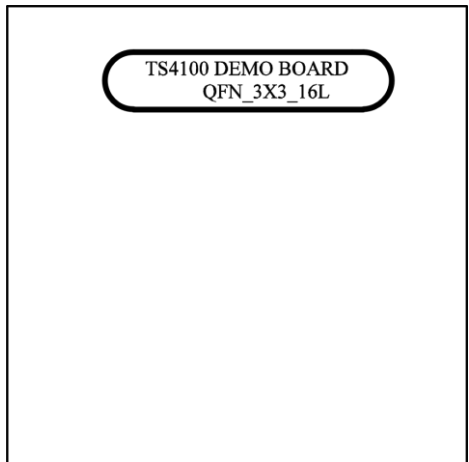

Figure 9. Bottom Layer 4 View #2