

REV.	DATE	ECR NO.	DESCRIPTION
NC	04/13/11	-	INITIAL RELEASE

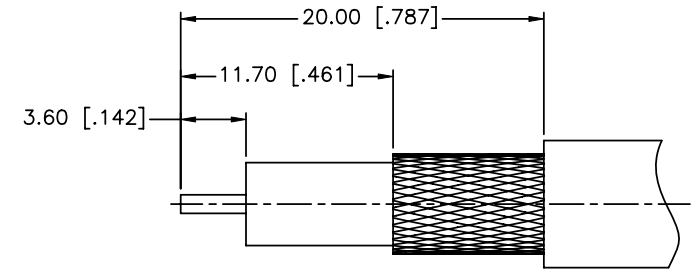

RECOMMENDED  
CABLE STRIPPING DIM'S

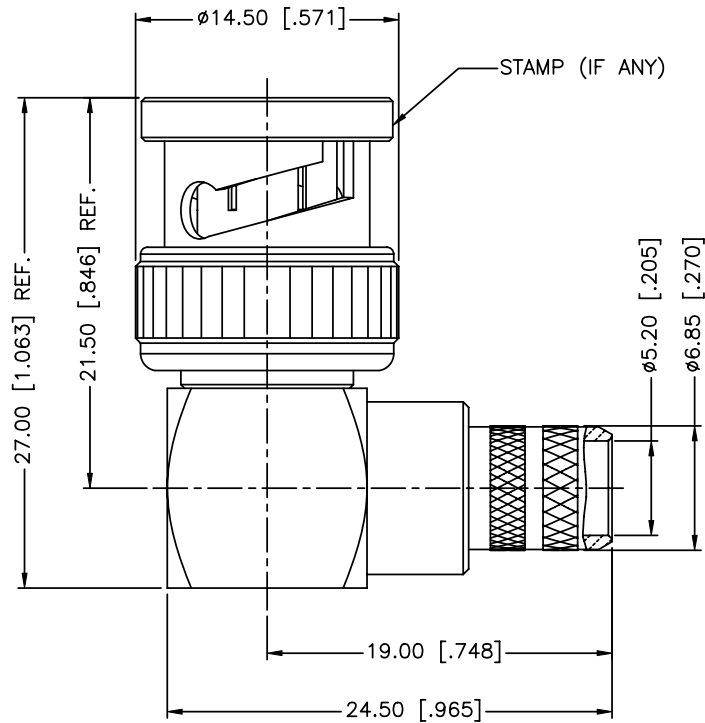
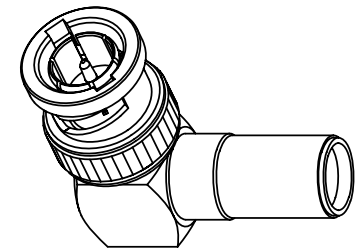
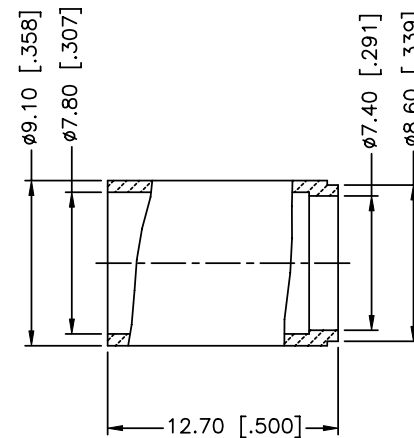
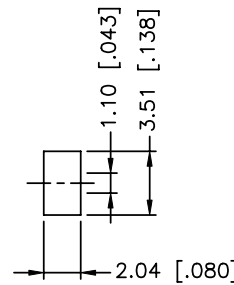

SCALE 2.000

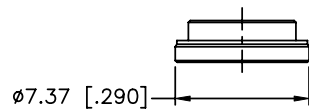

NOTE:

1. CRIMPED FERRULE  
HEX. CRIMP SIZE .319"
2. CONTACT PIN TO SOLDER

11	FERRULE	BRASS	NICKEL	1
10	NUT	BRASS	NICKEL	1
9	BARREL	BRASS	NICKEL	1
8	CONTACT PIN	BRASS	GOLD	1
7	WASHER	BRASS	NICKEL	1
6	SPRING	BERYLLIUM COPPER	NICKEL	1
5	RETAINER RING	BRASS	NICKEL	1
4	GASKET	RUBBER	RED	1
3	INSULATOR	PTFE	NATURAL	1
2	HOUSING	BRASS	NICKEL	1
1	SHELL	BRASS	NICKEL	1
DESCRIPTION	MATERIAL	FINISH	QTY	

UNLESS OTHERWISE SPECIFIED DIMENSIONS ARE IN MILLIMETERS. DIMENSIONS IN [ ] ARE IN INCHES AND FOR CUSTOMER REFERENCE ONLY.

UNLESS OTHERWISE SPECIFIED TOLERANCES FOR MILLIMETERS ARE:  
0.5 - 8mm ± 0.20mm  
8 - 30mm ± 0.40mm  
30 - 120mm ± 0.50mm

UNLESS OTHERWISE SPECIFIED TOLERANCES FOR INCHES ARE:  
.020 - .315 = ± 0.007"  
.315 - 1.180 = ± 0.015"  
1.180 - 4.724 = ± 0.020"

DO NOT SCALE DRAWING

APPROVALS	DATE
DRAWN M.ZHANG	04/13/11
CHECKED	
ISSUED	
SHEET 1 OF 1	
CAD FILE	C:/CONNEX/112990.DWG

<h1>Amphenol Connex</h1>		PART DESCRIPTION		
		<b>BNC R/A CRIMP PLUG (FOR BELDEN 1694A CABLE)</b>		
PART NO.		112990		
DWG. NO.	112990.DWG	REV.	NC	SIZE A
				SCALE NA