

Product data sheet

Specifications



Pressure switch 9012G, adjustable scale, 2 thresholds, 3.0 to 150 PSIG

9012GAW5G18

Main

Range of product	9012G
Pressure sensor type	Electromechanical pressure switch
Pressure sensor name	9012G
Pressure sensor size	1034.21 kPa
Maximum pressure	475 psi
Contacts type and composition	NC-NO, SPDT-DB, Form Z, snap action, silver nickel contacts
Controlled fluid	Hydraulic oil (-40...121 °C) Non-corrosive liquids Air Non-corrosive gas
Fluid connection type	0.25 inch 18 NPTF conforming to UL 508
Pressure switch type of operation	Regulation between 2 thresholds
Scale type	Adjustable differential
Local display	Without

Complementary

Range on decreasing pressure	20.68...1034.21 kPa
Approx adjustable differential at mid range	41.37...206.84 kPa +/- 2.5 % full scale
Cable entry	0.5 inch NPT conduit entrance
Terminal block type	4 screw terminals
Electrical connection	Screw-clamp terminals, AWG 22...AWG 12
Electrical circuit type	Control circuit
Local signalling	1 neon: (red) 120 V AC/DC (105...125 V)
[In] rated current	6 A 120 V AC 0.22 A 125 V DC
Setting	Internal
Enclosure material	Die cast aluminium alloy 380
Pressure actuator	Diaphragm nitrile (Buna-N)
Height	140.97 mm
Depth	78.99 mm

Width	88.90 mm
Operating position	Any position
Materials in contact with fluid	Nitrile (Buna-N) Nitrile (Buna-N)
Short-circuit protection	10 A cartridge overload and short-circuit protection, type gL
Maximum operating rate	120 cyc/mn
Mechanical durability	5000000 cycles
Repeat accuracy	4 %
Product weight	1.36 kg

Environment

Vibration resistance	2 gn (f= 40...150 Hz) conforming to IEC 68-2-6
Shock resistance	50 gn conforming to IEC 58-2-27
Standards	UL 508 CSA C22.2 No 14 UL 508
Product certifications	CSA LR25490 class 3211 03 UL listed file E12158 CCN NKPZ and CCN NTHT CSA LR25490 class 3211 03
NEMA degree of protection	NEMA 4/4X/13 conforming to UL 50
Ambient air temperature for operation	-23...85 °C

Packing Units

Unit Type of Package 1	PCE
Number of Units in Package 1	1
Package 1 Height	61.29 cm
Package 1 Width	24.13 cm
Package 1 Length	155.677 cm
Package 1 Weight	1.361 kg

Offer Sustainability

REACH Regulation	REACH Declaration
EU RoHS Directive	Not applicable, out of EU RoHS legal scope
Environmental Disclosure	Product Environmental Profile
Circularity Profile	End of Life Information
California proposition 65	WARNING: This product can expose you to chemicals including: Diisononyl phthalate (DINP), which is known to the State of California to cause cancer, and Di-isodecyl phthalate (DIDP), which is known to the State of California to cause birth defects or other reproductive harm. For more information go to www.P65Warnings.ca.gov

Contractual warranty

Warranty	18 months
-----------------	-----------

Dimensions

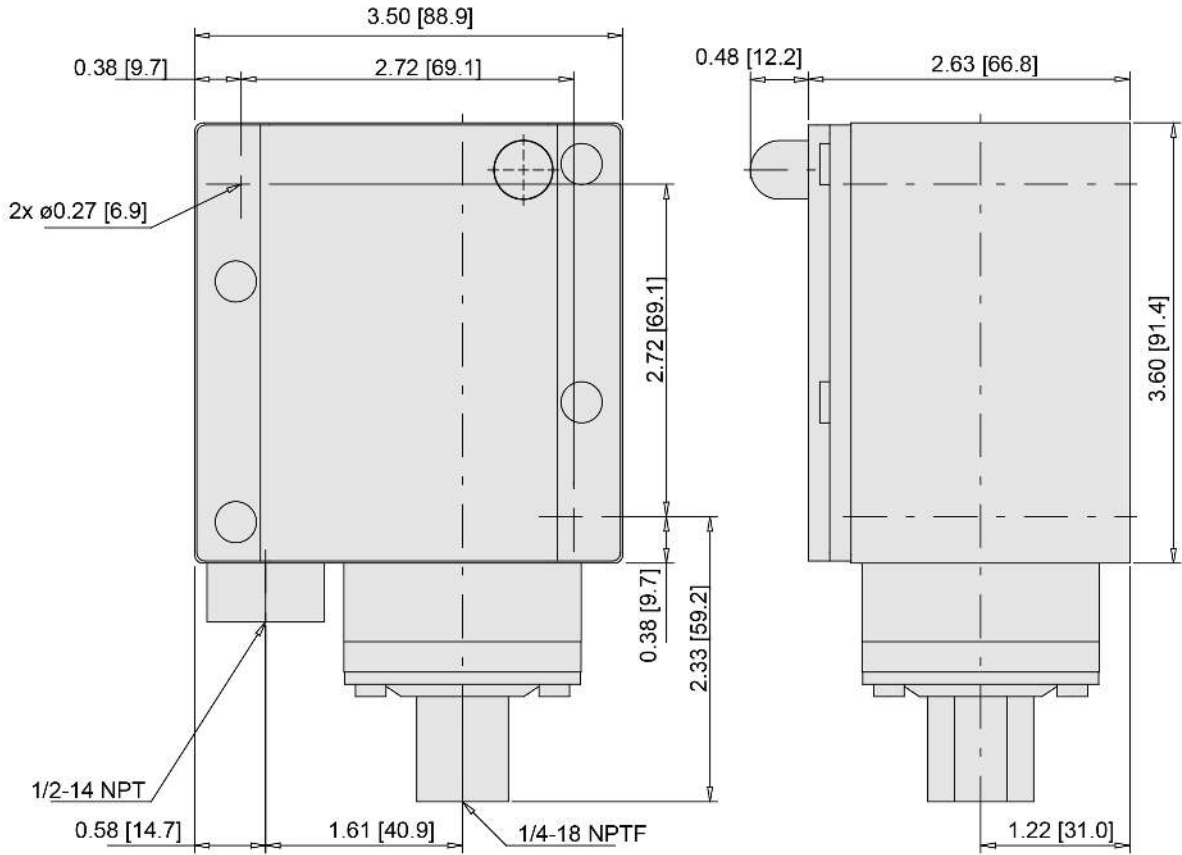

in. [mm]

Recommended replacement(s)