

CONNECTOR ASSEMBLY EXAMPLARY LOADED

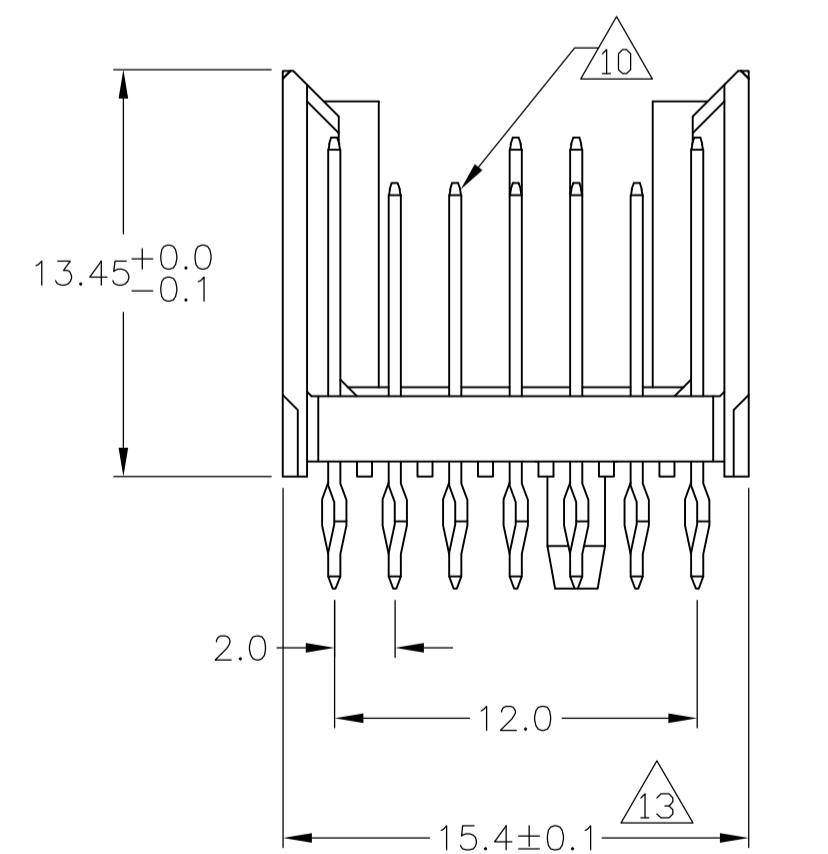

CONTACT DIMENSIONS SCALE 5:1

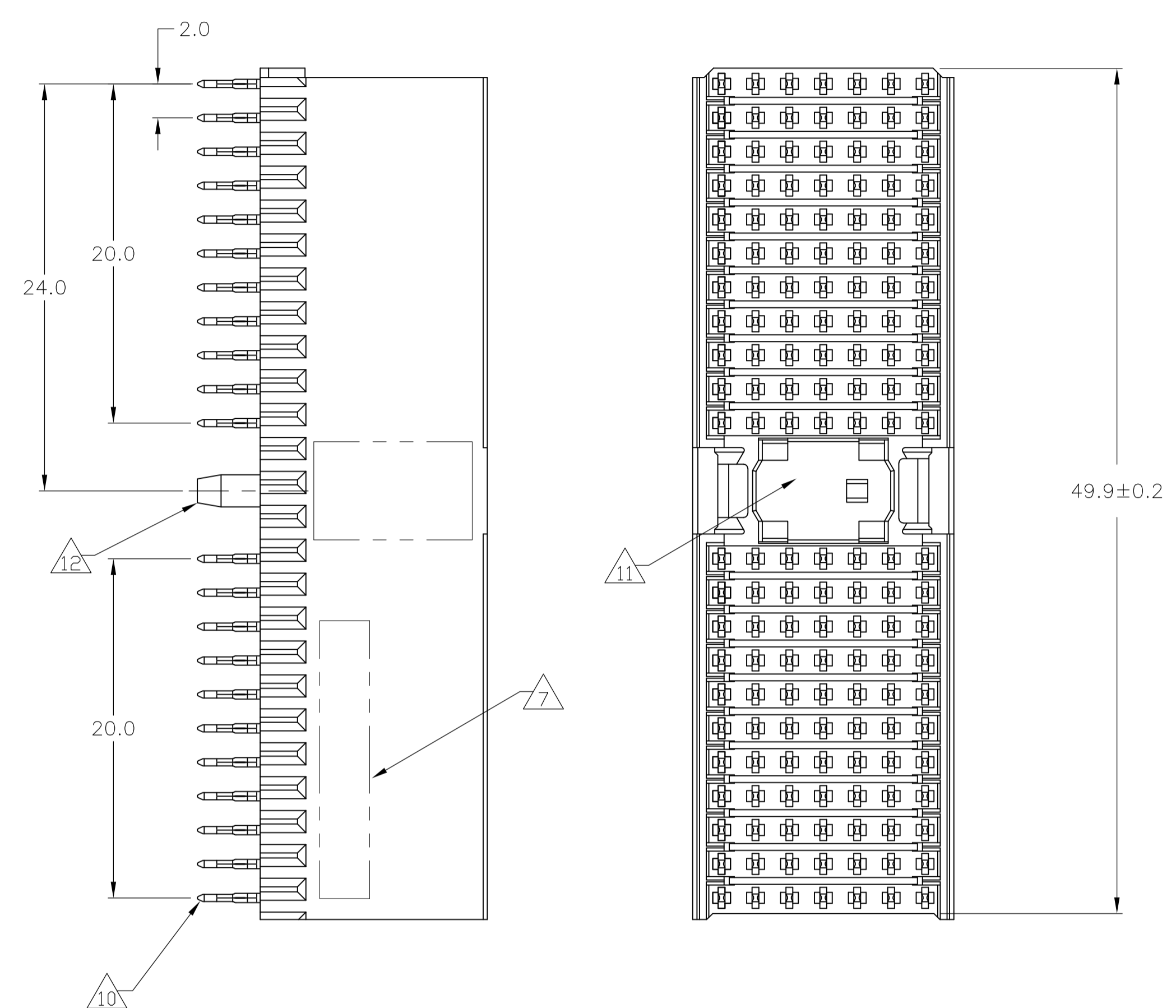
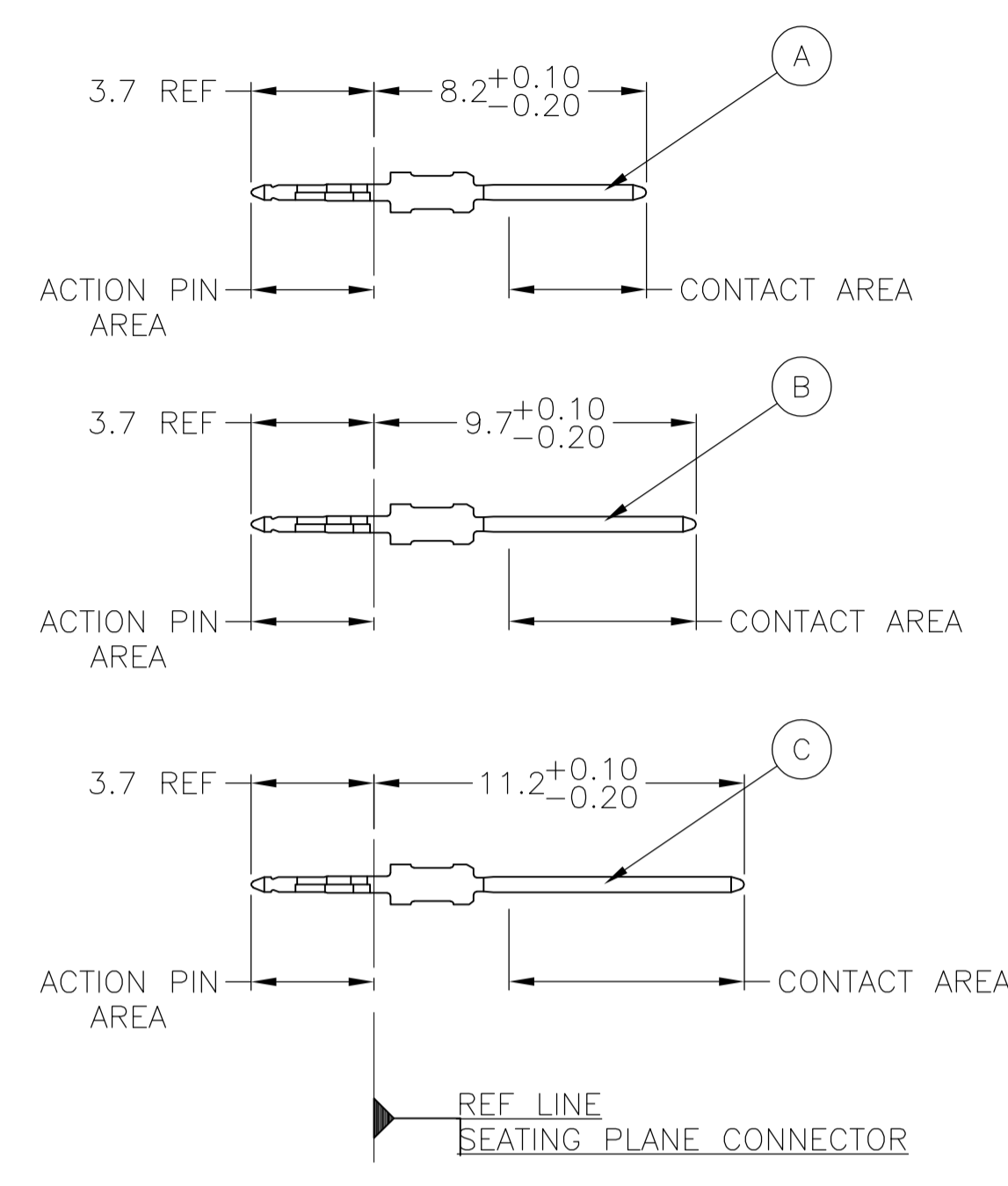

CONTACT LAYOUT

	z	a	b	c	d	e	f
1	C	B	B	B	B	B	C
2	C	B	B	C	B	B	C
3	C	B	B	B	C	B	C
4	C	B	B	C	B	B	C
5	C	B	B	B	B	B	C
6	C	B	B	B	B	B	C
7	C	B	B	B	C	B	C
8	C	B	B	B	B	B	C
9	C	B	B	B	C	B	C
10	C	B	B	B	B	B	C
11	C	B	B	B	A	B	C
MULTI PURPOSE CENTER							
15	C	B	B	B	C	B	C
16	C	B	B	B	B	B	C
17	C	B	A	B	C	B	C
18	C	B	B	B	B	B	C
19	C	B	B	B	C	B	C
20	C	B	B	C	B	B	C
21	C	B	B	B	C	B	C
22	C	B	B	C	B	B	C
23	C	B	B	B	C	B	C
24	C	B	B	B	B	B	C
25	C	B	B	B	B	B	C

RECOMMENDED PCB-HOLE LAYOUT COMPONENT SIDE SHOWN

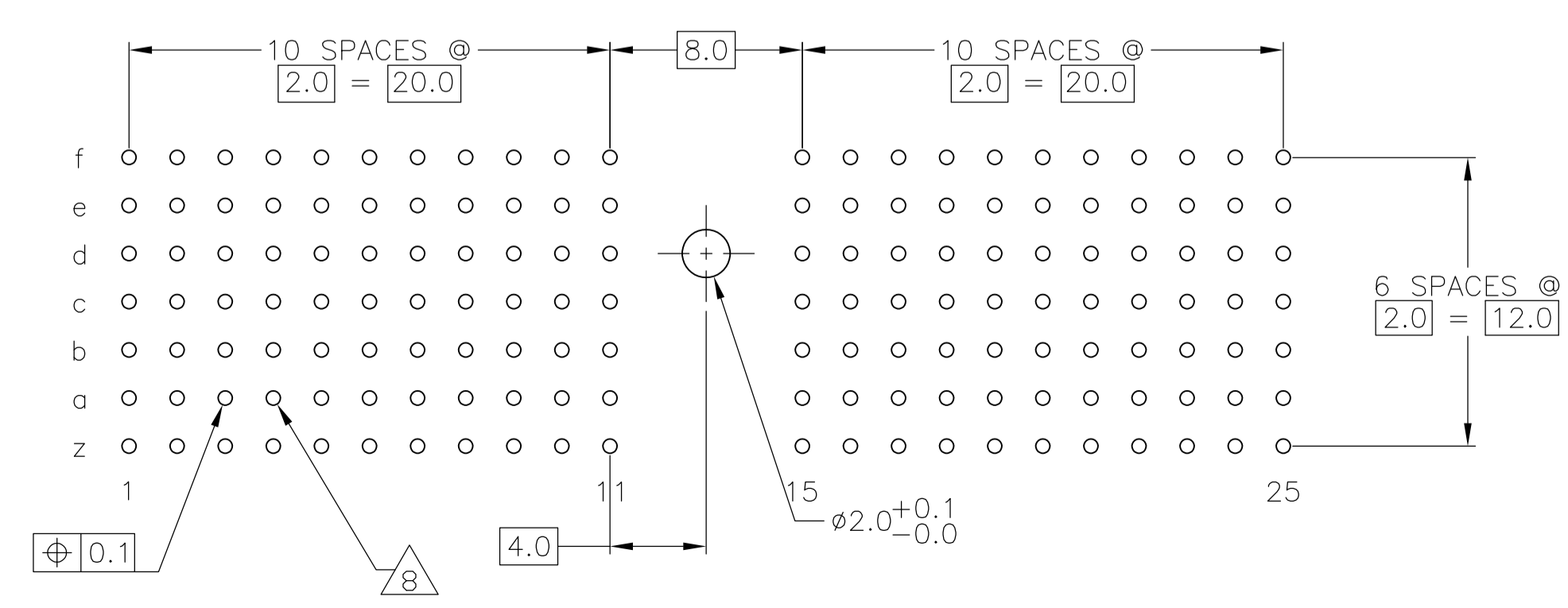

PLATED THRU HOLES PARAMETERS REFERENCE APPLICATION SPECIFICATION

OBSOLETE	2 3 15	3-352332-0
	2 6 14	1-352332-9
	2 5 14	352332-9
	2 4	352332-4
	2 3	352332-1
FINISH		PART NUMBER

THIS DRAWING IS A CONTROLLED DOCUMENT.

DIMENSIONS: mm	TOLERANCES UNLESS OTHERWISE SPECIFIED:	DIN B CARBO 26JUL05	26JUL05	Tyco Electronics Corporation Harrisburg, Pa 17105-3608
0-PLC ±	1-PLC ±0.1	2-PLC ±	3-PLC ±	4-PLC ±
ANGLES	±0.2	APVD G SKIPPER 26JUL05	NAME G SKIPPER	MALE ASSEMBLY, Z-PACK 2mm HM, TYPE A
MATERIAL	FINISH SEE TABLE	108-19082	APPLICATION SPEC 114-19029	SIZE A1
		WEIGHT	00779	C=352332
		CUSTOMER DRAWING	SCALE 4:1	SHEET 1 OF 2

LOC		DIST		REVISIONS				
P	LTR	DESCRIPTION	DATE	DN	APVD			
AD	00	SEE SHEET 1	-	-	-			

- 1 MATERIAL:
CONTACT: PHOSPHOR BRONZE.
HOUSING: GLASS-FILLED POLYESTER.
- 2 GENERAL PLATING SPECIFICATION: UNDERPLATING
(ENTIRE CONTACT): 1.27µm MIN NICKEL AND ACTION
PIN: 0.5µm MIN TIN LEAD.
FOR PLATING OF MATING SURFACES SEE APPLICABLE
SPECIFICATION REFERENCE FOR EACH DASH NUMBER.
- 3 CONFORMS TO ALL TESTING ACCORDING TO IEC 61076-4-101
PERFORMANCE LEVEL 2.
- 4 CONFORMS TO ALL TESTING ACCORDING TO IEC 61076-4-101
PERFORMANCE LEVEL 1.
- 5 CONNECTOR TESTED AND QUALIFIED AGAINST TELCORDIA GR-1217-CORE QUALITY LEVEL 3,
CENTRAL OFFICE APPLICATIONS.
- 6 CONNECTOR TESTED AND QUALIFIED AGAINST TELCORDIA GR-1217-CORE QUALITY LEVEL 3,
UNCONTROLLED ENVIROMENT APPLICATIONS.
- 7 CONNECTOR MARKED WITH PART NUMBER AND DATE CODE.
ADDITIONAL CHARACTERS OR MARKINGS, AS WELL AS THE LOCATION OF THE MARKINGS,
MAY BE ADDED FOR TRACEABILITY BASED UPON MANUFACTURERS DISCRETION.
- 8 PLATED-THROUGH HOLES AT 2x2mm SQUARE GRID
PATTERN DEFINED BY CONTACT LAYOUT.
- 9 FOR ACTUAL PIN LOADING SEE "CONTACT LAYOUT".
- 10 FOR ACTUAL PIN DIMENSIONS SEE "CONTACT DIMENSIONS".
- 11 AREA RESERVED FOR KEYING PART (BASIC P/N 100525)
- 12 POLARIZATION FEATURE.
- 13 TO BE MEASURED AT BOTTOM OF SHROUD.
- 14 CONNECTOR LUBRICATED WITH BELCORE APPROVED LUBRICANT,
TECHNICAL REFERENCE: TR-NWT-001217 ISSUE 1, SEP 1992.
- 15 0.76µm MIN GOLD PLATING ON MATING SURFACES

THIS DRAWING IS A CONTROLLED DOCUMENT.		DIN B CARBO	26JUL05	 Tyco Electronics Corporation Harrisburg, Pa 17105-3608	
		CHK G SKIPPER	26JUL05		
DIMENSIONS: mm		TOLERANCES UNLESS OTHERWISE SPECIFIED: 0-PLG ± 1-PLG ±0.1 2-PLG ± 3-PLG ± 4-PLG ± ANGLES ±		APVD G SKIPPER 26JUL05 PRODUCT SPEC 108-19082 APPLICATION SPEC 114-19029	NAME MALE ASSEMBLY, Z-PACK 2mm HM, TYPE A
MATERIAL SEE SHEET 1	FINISH SEE SHEET 1	WEIGHT -	SIZE A1	CAGE CODE 00779 DRAWING NO C=352332 RESTRICTED TO -	
CUSTOMER DRAWING			SCALE 4:1	SHEET 2 OF 2 REV H1	