

REVISIONS					
REV	ECO	DESCRIPTION	DATE	BY	APPR
A1	-	FIRST RELEASE	May.12,2015	DRACK	TOMMY

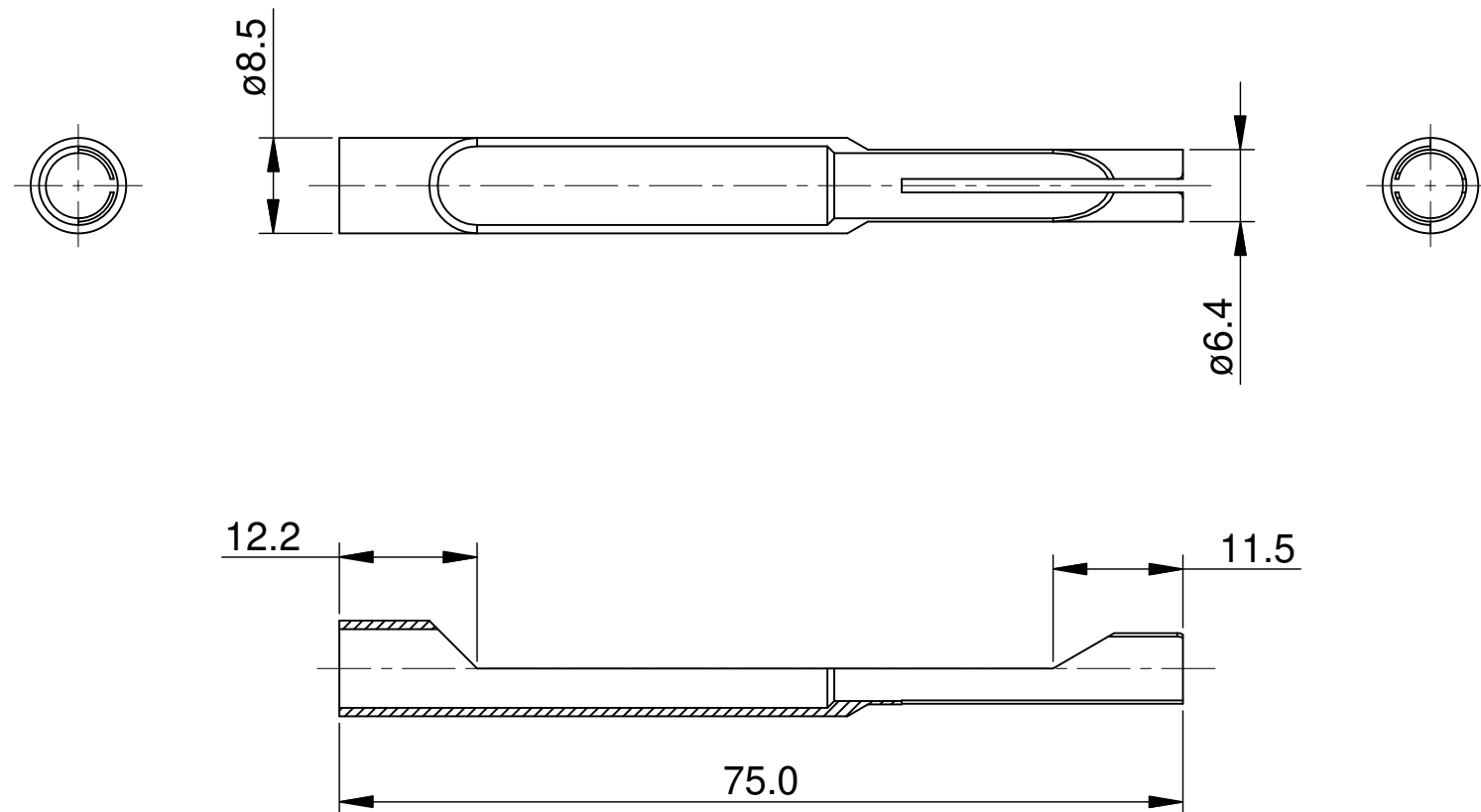

NOTES: UNLESS OTHERWISE SPECIFIED

1. MATERIAL: BERRYLIUM COPPER, NICKEL PLATED
2. SPECIFICATIONS:
 - 2.1 AVAILABLE RANGE: 3.6mm CONTACT
 - 2.2 RoHS COMPLIANT
3. ALL DIMENSIONS ARE FOR REFERENCE USE ONLY.

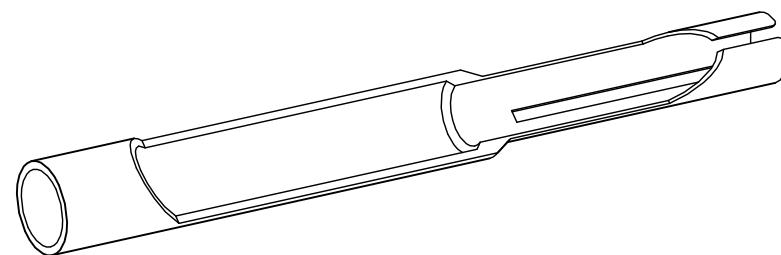

TITLE: M40 Extraction tooling,8#
 DWG NO: 50-54931-3
 REV: A1
 SH: 1
 OF: 1

QUANTITY	SEE PART NUMBER CHART PART NUMBER	DESCRIPTION	ITEM
MATERIALS LIST			
UNLESS OTHERWISE SPECIFIED 1) All dimensions are in metric(mm). 2) Tolerances are as follows: 1 PL DEC ±0.30 2 PL DEC ±0.15 3 PL DEC ±0.08 Fractions ±1/64 Angles ±1° 3) Note reference =		SIGNATURES DRAWN: DRACK CHECKED: ENGINEER: APPROVAL: DATE: May.12,2015	<div style="text-align: center; font-size: 24pt; font-weight: bold;">Amphenol</div> Sine Systems - www.amphenol-sine.com 44724 Morley Drive Clinton Township, MI 48036
MATERIAL SPECIFICATIONS:		CUSTOMER:	M40,Extraction tooling,8#
PROCESS SPECIFICATIONS:		THIS DRAWING IS SUPPLIED FOR INFORMATION ONLY. DESIGN FEATURES, SPECIFICATIONS AND PERFORMANCE DATA SHOWN HEREON ARE THE PROPERTY OF THE AMPHENOL CORPORATION. NO RIGHTS OF REPRODUCTION ARE IMPLIED. ALL DIMENSIONS ARE SUBJECT TO NORMAL MANUFACTURING VARIATIONS.	
NEXT ASSY:		SIZE: B TYPE: C- SCALE: NONE	DWG NO: 50-54931-3 REVISION: A1 SHEET 1 OF 1