

Helping Customers Innovate, Improve & Grow



Description

Vectron's VC-711 Crystal Oscillator is a quartz stabilized, differential output oscillator, operating off either a 2.5 or 3.3 volt power supply in a hermetically sealed 7.0 x 5.0mm ceramic package.

Features

- Ultra Low Jitter Performance, 3rd OT or Fundamental Crystal Design
- Extended Operating Temperature Range, -40 to 105°C Option
- 10MHz -170MHz Output Frequencies
- Excellent Power Supply Rejection Ratio
- Enable/Disable
- 3.3 or 2.5V operation
- EHermetically Sealed 7.0 x 5.0mm Ceramic Package
- Product is compliant to RoHS directive  and fully compatible with lead free assembly

Applications

- Ethernet, GbE, Synchronous Ethernet
- PCIe
- Fiber Channel
- Enterprise Servers and Storage
- Test and Measurement
- GPON
- Clock source for ADC's, DAC's, FPGA's

Block Diagram

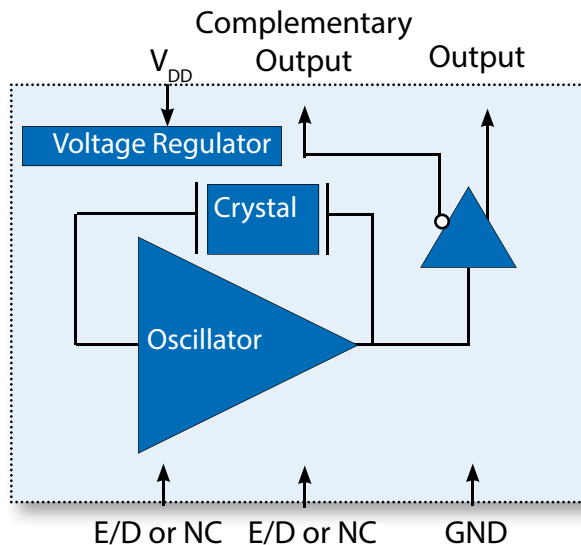

Performance Specifications

Table 1. Electrical Performance, LVPECL Option					
Parameter	Symbol	Min	Typical	Maximum	Units
Supply Voltage ¹ (Ordering Option)	V_{DD}	3.135 2.375	3.3 2.5	3.465 2.625	V V
Current Consumption, 3.3V 2.5V	I_{DD}			69 61	mA
Frequency					
Nominal Frequency (Ordering Option)	f_N	10		170	MHz
Stability ² (Ordering Option)		±20, ±25, ±50 or ±100			ppm
Outputs					
Output Logic Levels ³					
Output Logic High	V_{OH}	$V_{DD} - 1.025$		$V_{DD} - 0.880$	V
Output Logic Low	V_{OL}	$V_{DD} - 1.810$		$V_{DD} - 1.620$	V
Output Rise and Fall Time ^{3,4}	t_R/t_F			450	ps
Load		50 ohms into $V_{DD} - 2.0V$			
Duty Cycle ⁵	DC	45		55	%
Phase Noise, 3.3V, 156.25MHz ⁶					
10Hz	ϕ_N		-74		dBc/Hz
100Hz			-105		
1kHz			-134		
10kHz			-147		
100kHz			-155		
1MHz			-156		
20MHz			-158		
Jitter ⁶ , 156.25MHz 12kHz -20MHz	ϕ_j		75	100	fs
Enable/Disable					
Outputs Enabled ⁷	V_{IH}	$0.7 * V_{DD}$			V
Outputs Disabled	V_{IL}			$0.3 * V_{DD}$	V
Disable Time	t_D			200	ns
Enable/Disable Leakage Current				±200	uA
Start-Up Time	t_{SU}			10	ms
Operating Temp. (Ordering Option)	T_{OP}	-10/70 or -40/85 or -40/105			°C

1. The VC-711 power supply pin should be filtered, eg, a 10uf, 0.1uf and 0.01uf capacitor.
2. Includes calibration tolerance, operating temperature, supply voltage variations, aging and IR reflow.
3. Figure 1 defines the test circuit and Figure 2 defines these parameters.
4. Output rise and fall time will be 600ps (max) for -40/105 °C operating temperature range.
5. Duty Cycle is defined as the On/Time Period.
6. Measured using an Agilent E5052 Signal Source Analyzer at 25 °C.
7. Outputs will be Enabled if Enable/Disable is left open.

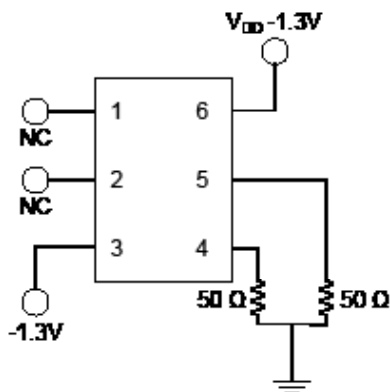

Figure 1.

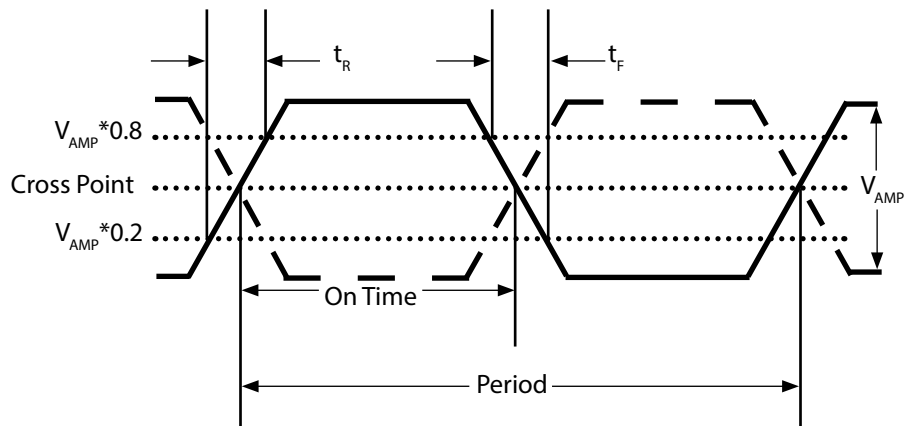

Figure 2.

Performance Specifications

Table 2. Electrical Performance, LVDS Option

Parameter	Symbol	Min	Typical	Maximum	Units
Supply					
Supply Voltage ¹ (Ordering Option)	V_{DD}	3.135 2.375	3.3 2.5	3.465 2.625	V V
Current Consumption, 3.3V 2.5V	I_{DD}			33 29	mA
Frequency					
Nominal Frequency (Ordering Option)	f_N	10		170	MHz
Stability ² (Ordering Option)		±20, ±25, ±50 or ±100			ppm
Outputs					
Output Logic Levels ³ Output Logic High Output Logic Low	V_{OH} V_{OL}	0.9	1.43 1.10	1.6	V V
Output Amplitude		247	350	454	mV
Differential Output Error				50	mV
Offset Voltage		1.125	1.25	1.375	V
Offset Voltage Error				50	mV
Output Leakage Current, Outputs Disabled				10	µA
Output Rise and Fall Time ^{3,4}	t_R/t_F			450	ps
Load		100 ohms differential			
Duty Cycle ⁵	DC	45		55	%
Phase Noise, 3.3V, 156.25MHz ⁶ 10Hz 100Hz 1kHz 10kHz 100kHz 1MHz 20MHz	ϕ_N		-69 -102 -130 -148 -154 -156 -159		dBc/Hz
Jitter ⁶ , 156.25MHz 12kHz - 20MHz	ϕ_j		75	100	fs
Enable/Disable					
Outputs Enabled ⁷ Outputs Disabled	V_{IH} V_{IL}	0.7* V_{DD}		0.3* V_{DD}	V V
Disable Time	t_D			200	ns
Enable/Disable Leakage Current	$I_{E/D}$			±200	µA
Start-Up Time	t_{SU}			10	ms
Operating Temp. (Ordering Option)	T_{OP}	-10/70 or -40/85 or -40/105			°C

1. The VC-711 power supply pin should be filtered, eg, a 10uf, 0.1 uf and 0.01 uf capacitor.
2. Includes calibration tolerance, operating temperature, supply voltage variations, aging and IR reflow.
3. Figure 2 defines these parameters and Figure 3 defines the test circuit.
4. Output rise and fall time will be 600ps (max) for -40/105 °C operating temperature range.
5. Duty Cycle is defined as the On/Time Period.
6. Measured using an Agilent E5052 Signal Source Analyzer at 25 °C
7. Outputs will be Enabled if Enable/Disable is left open.

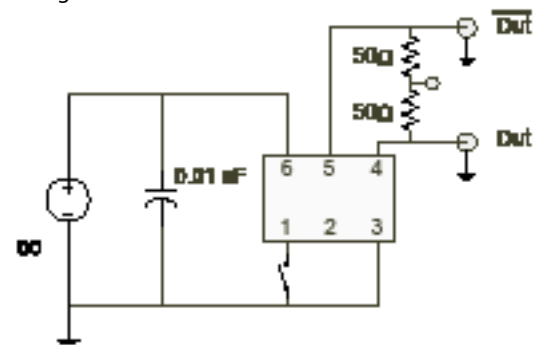

Figure 3.

Package and Pinout

Table 3. Pinout

Pin #	Symbol	Function
1	E/D or NC	Enable/Disable or No Connection
2	E/D or NC	Enable Disable or No Connection
3	GND	Electrical and Lid Ground
4	f_o	Output Frequency
5	Cf_o	Complementary Output Frequency
6	V_{DD}	Supply Voltage

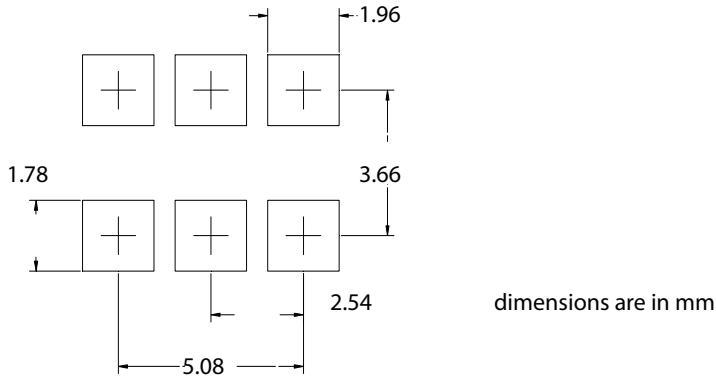

Figure 4. Pad Layout

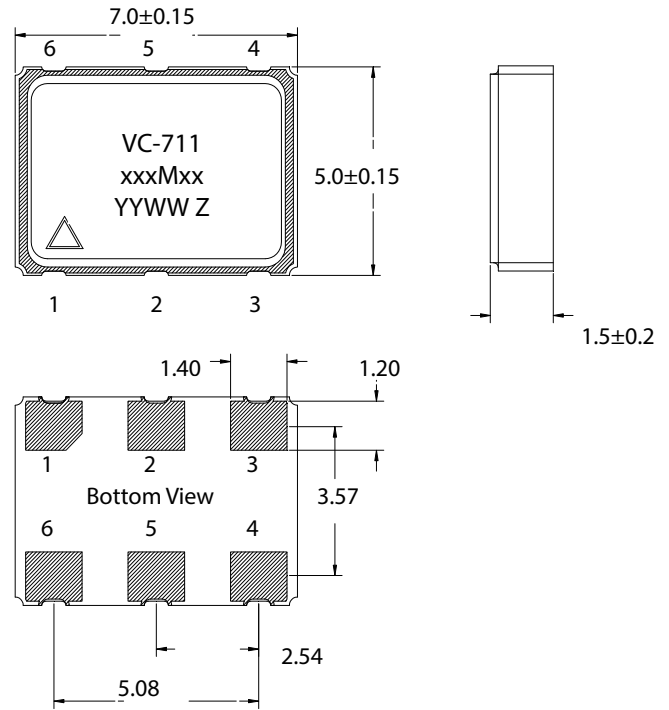

Figure 5. Package Outline Drawing

Marking Information
 VC-711 - Product Type
 xxxMxx - Frequency (156M25)
 YY - Year of Manufacture
 WW - Week of the Year
 Z - Manufacturing Location

LVPECL Application Diagrams

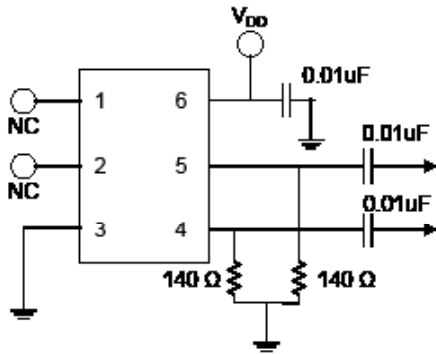

Figure 6. Single Resistor Termination Scheme
 Resistor values are typically 140 ohms for 3.3V operation and 84 ohms for 2.5V operation.

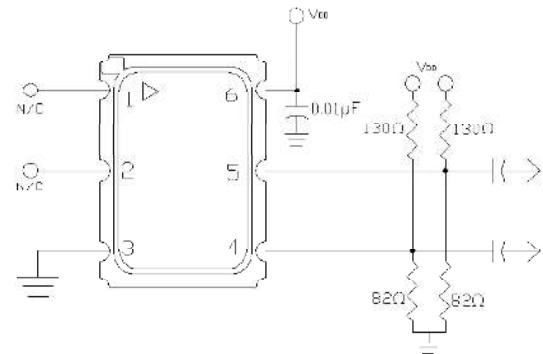

Figure 7. Pull-Up Pull Down Termination
 Resistor values shown are typical for 3.3 V operation. For 2.5V operation, the resistor to ground is 62 ohms and the resistor to supply is 250 ohms

The VC-711 incorporates a standard PECL output scheme, which are un-terminated FET drains. There are numerous application notes on terminating and interfacing PECL logic and the two most common methods are a single resistor to ground, Figure 6, or for best 50 ohm matching a pull-up/pull-down scheme as shown in Figure 7 should be used. AC coupling capacitors are optional, depending on the application and the input logic requirements of the next stage.

One of the most important considerations is terminating the Output and Complementary Outputs equally. An unused output should not be left un-terminated, and if it one of the two outputs is left open it will result in excessive jitter on both. PC board layout must take this and 50 ohm impedance matching into account. Load matching and power supply noise are the main contributors to jitter related problems.

LVDS Application Diagrams

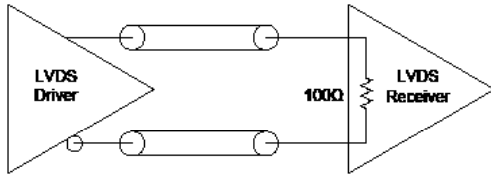

Figure 6. LVDS to LVDS Connection, Internal 100ohm Resistor

Some LVDS structures have an internal 100 ohm resistor on the input and do not need additional components. AC blocking capacitors can be used if the DC levels are incompatible.

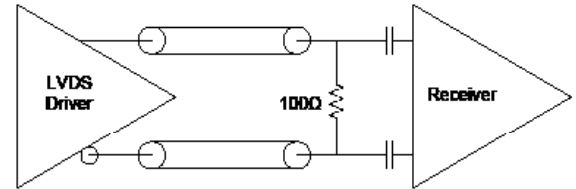

Figure 7. LVDS to LVDS Connection

Some input structures may not have an internal 100 ohm resistor on the input and will need an external 100ohm resistor for impedance matching. Also, the input may have an internal DC bias which may not be compatible with LVDS levels, AC blocking capacitors can be used.

One of the most important considerations is terminating the Output and Complementary Outputs equally. An unused output should not be left un-terminated, and if it one of the two outputs is left open it will result in excessive jitter on both. PC board layout must take this and 50 ohm impedance matching into account. Load matching and power supply noise are the main contributors to jitter related problems.

IR Compliance

Suggested IR Profile

Devices are built using lead free epoxy and can be subjected to standard lead free IR reflow conditions shown in Table 4. Contact pads are gold over nickel and lower maximum temperatures can also be used, such as 220C.

Parameter	Symbol	Value
PreHeat Time	t_s	200 sec Max
Ramp Up	R_{UP}	3°C/sec Max
Time above 217°C	t_L	150 sec Max
Time to Peak Temperature	t_{AMB-P}	480 sec Max
Time at 260°C	t_P	30 sec Max
Time at 240°C	t_{P2}	60 sec Max
Ramp down	R_{DN}	6°C/sec Max

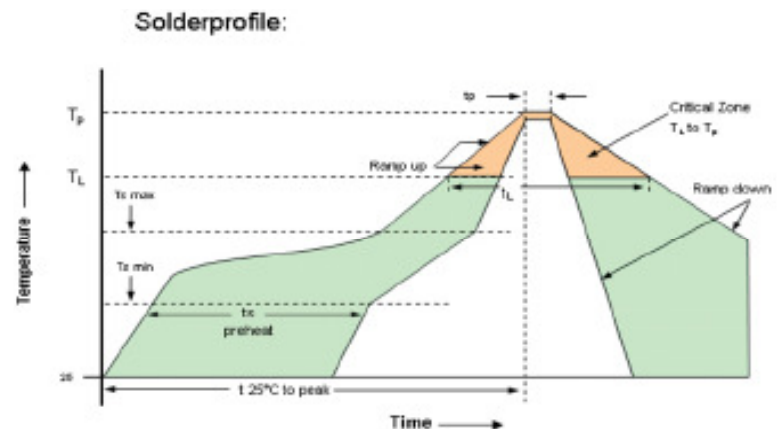

Environmental Compliance

Parameter	Condition
Mechanical Shock	MIL-STD-883 Method 2002
Mechanical Vibration	MIL-STD-883 Method 2007
Temperature Cycle	MIL-STD-883 Method 1010
Solderability	MIL-STD-883 Method 2003
Fine and Gross Leak	MIL-STD-883 Method 1014
Resistance to Solvents	MIL-STD-202 Method 215
Moisture Sensitivity Level	MSL1
Contact Pads	Gold (0.3-1.0um) over Nickel
ThetaJC (bottom of case)	24 °C/W

Maximum Ratings, Tape & Reel

Absolute Maximum Ratings and Handling Precautions

Stresses in excess of the absolute maximum ratings can permanently damage the device. Functional operation is not implied or any other excess of conditions represented in the operational sections of this data sheet. Exposure to absolute maximum ratings for extended periods may adversely affect device reliability. Although ESD protection circuitry has been designed into the VC-711, proper precautions should be taken when handling and mounting, VI employs a Human Body Model and Charged Device Model for ESD susceptibility testing and design evaluation. ESD thresholds are dependent on the circuit parameters used to define the model. Although no industry standard has been adopted for the CDM a standard resistance of 1.5kOhms and capacitance of 100pF is widely used and therefor can be used for comparison purposes.

Parameter	Value	Unit
Storage Temperature	-55 to 125	°C
Junction Temperature (maximum)	150	°C
Supply Voltage	-0.5 to 5.0	V
Enable Disable Voltage	-0.5 to $V_{DD}+0.5$	V
ESD, Human Body Model	1500	V
ESD, Charged Device Model	1500	V

Table 7. Tape and Reel Information

Tape Dimensions (mm)						Reel Dimensions (mm)						
W	F	Do	Po	P1	A	B	C	D	N	W1	W2	#/Reel
16	7.5	1.5	4	8	180	2	13	21	50	17	21	250

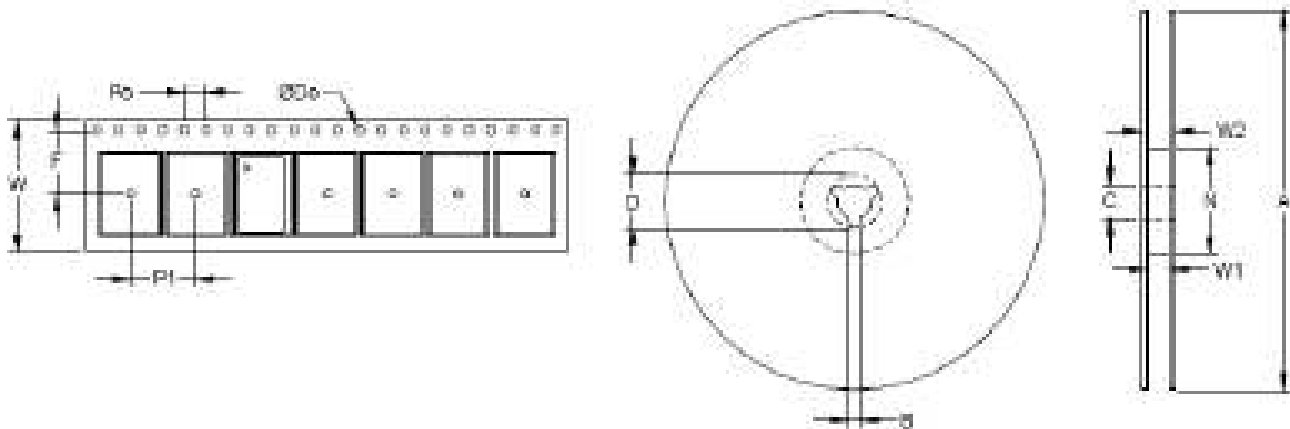

Ordering Information

VC-711- E C E - K A A N - xxxMxxxxxx

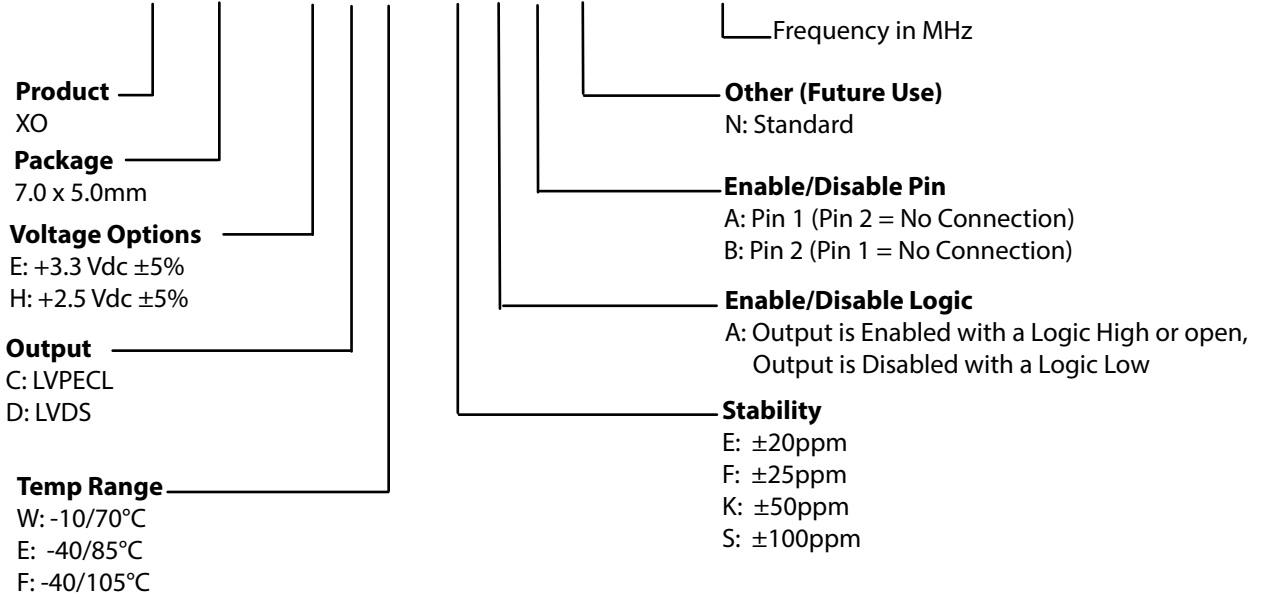

Example: VC-711-ECE-KAAN-156M250000

* Add **_SNPBDIP** for tin lead solder dip
Example: VC-711-ECE-KAAN-156M250000_SNPBDIP

Notes:

- a) Only ±100ppm stability option is available for temperature range of -40/105 °C. ±50ppm is available in some cases.
- b) Not all combinations of options are available. Other specifications may be available upon request. Consult with factory.

Revision History

Revision Date	Approved	Description
Feb 07, 2017	RC	Rev 0.1: VC-711 Preliminary datasheet for factory approval (Internal Revision)
July 16, 2017	VN	Rev 0.2: Internal Revision based on factory information and Website release.
Sept 10, 2018	FB	Update logo and contact information, add thetaJC, add SNPBDIP ordering option



Microsemi, a wholly owned subsidiary of Microchip Technology Inc. (Nasdaq: MCHP), offers a comprehensive portfolio of semiconductor and system solutions for aerospace & defense, communications, data center and industrial markets. Products include high-performance and radiation-hardened analog mixed-signal integrated circuits, FPGAs, SoCs and ASICs; power management products; timing and synchronization devices and precise time solutions, setting the world's standard for time; voice processing devices; RF solutions; discrete components; enterprise storage and communication solutions, security technologies and scalable anti-tamper products, Ethernet solutions, Power-over-Ethernet ICs and midspans, as well as custom design capabilities and services. Learn more at www.microsemi.com.

Microsemi Headquarters
One Enterprise, Aliso Viejo, CA 92656 USA
Within the USA: +1 (800) 713-4113
Outside the USA: +1 (949) 380-6100
Sales: +1 (949) 380-8136
Fax: +1 (949) 215-4996
email: sales.support@microsemi.com
www.microsemi.com

Microsemi makes no warranty, representation, or guarantee regarding the information contained herein or the suitability of its products and services for any particular purpose, nor does Microsemi assume any liability whatsoever arising out of the application or use of any product or circuit. The products sold hereunder and any other products sold by Microsemi have been subject to limited testing and should not be used in conjunction with mission-critical equipment or applications. Any performance specifications are believed to be reliable but are not verified, and Buyer must conduct and complete all performance and other testing of the products, alone and together with, or installed in, any end-products. Buyer shall not rely on any data and performance specifications or parameters provided by Microsemi. It is the Buyer's responsibility to independently determine suitability of any products and to test and verify the same. The information provided by Microsemi hereunder is provided "as is, where is" and with all faults, and the entire risk associated with such information is entirely with the Buyer. Microsemi does not grant, explicitly or implicitly, to any party any patent rights, licenses, or any other IP rights, whether with regard to such information itself or anything described by such information. Information provided in this document is proprietary to Microsemi, and Microsemi reserves the right to make any changes to the information in this document or to any products and services at any time without notice.

©2018 Microsemi, a wholly owned subsidiary of Microchip Technology Inc. All rights reserved. Microsemi and the Microsemi logo are registered trademarks of Microsemi Corporation. All other trademarks and service marks are the property of their respective owners.