

THIS DRAWING IS UNPUBLISHED. RELEASED FOR PUBLICATION
 © COPYRIGHT - By - ALL RIGHTS RESERVED.

LOC		DIST		REVISIONS			
P	LTR	DESCRIPTION		DATE	DWN	APVD	
AF	50	B1	ECR-13-017177	05NOV13	PKS	RRP	

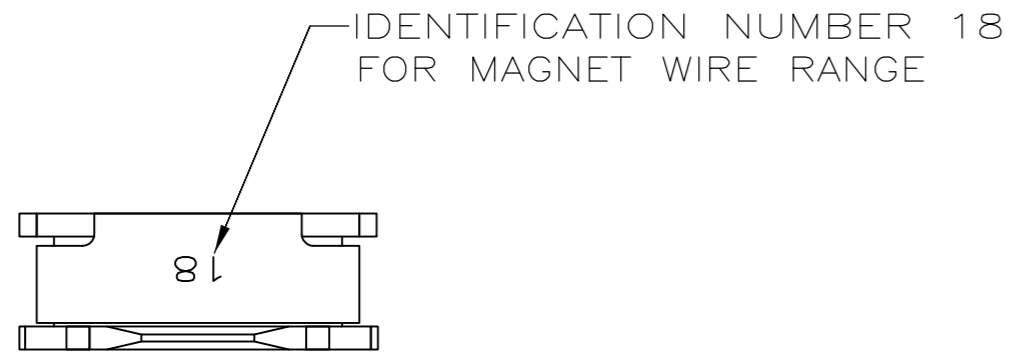

- 1 SLOT ACCEPTS 0.64-0.81mm [#22-#20] AWG COPPER MAGNET WIRE. 2 WIRES OF THE SAME SIZE MAX PER SLOT.
- 2 AFTER INSERTION INTO PLASTIC HOLDER TAB PORTION MUST BE BENT OVER 45° TO 90° OR POTTED-IN TO PREVENT PULL-OUT WHEN MATING RECEPTACLE IS DISCONNECTED.
- 3 TIN PLATE

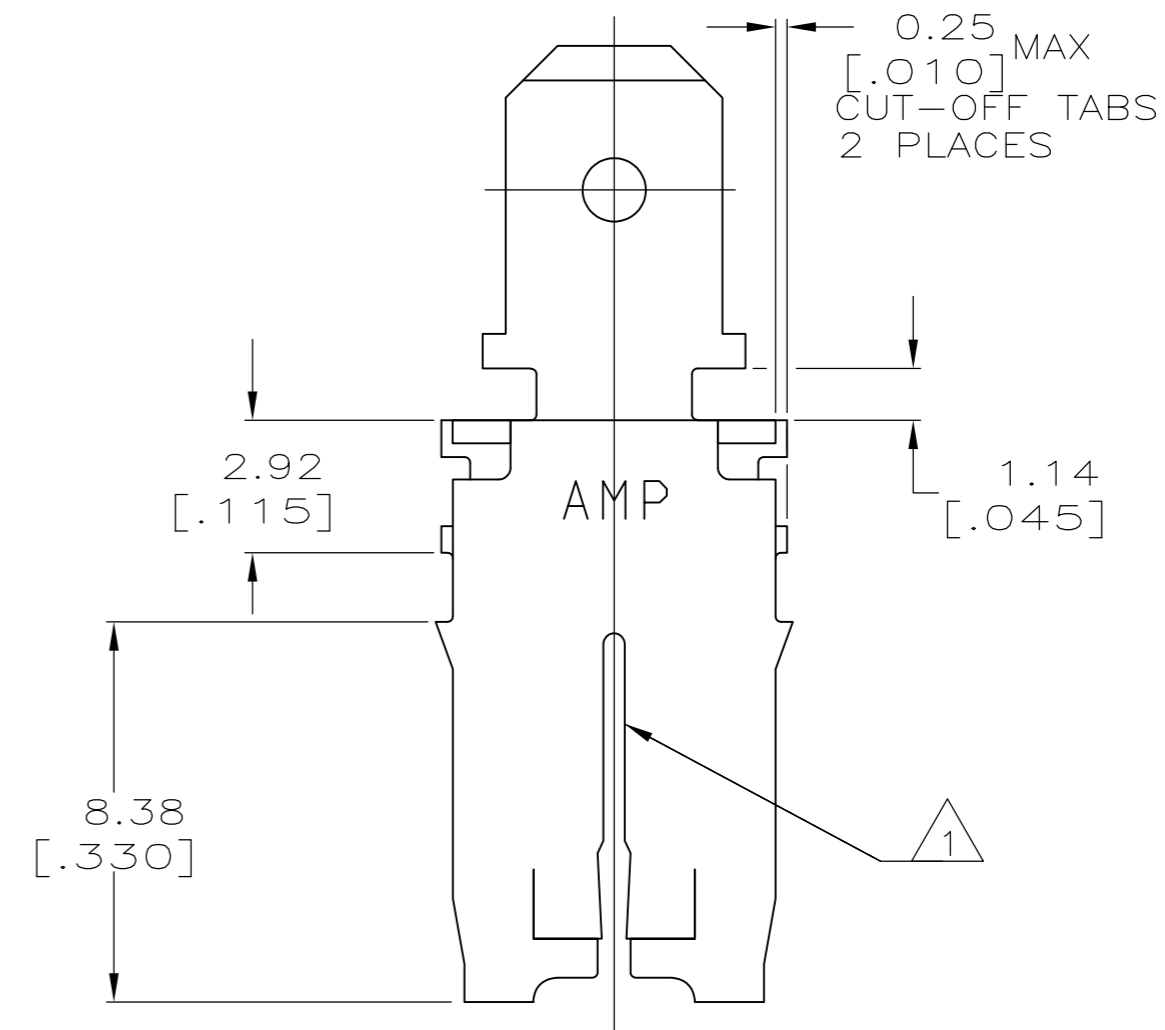
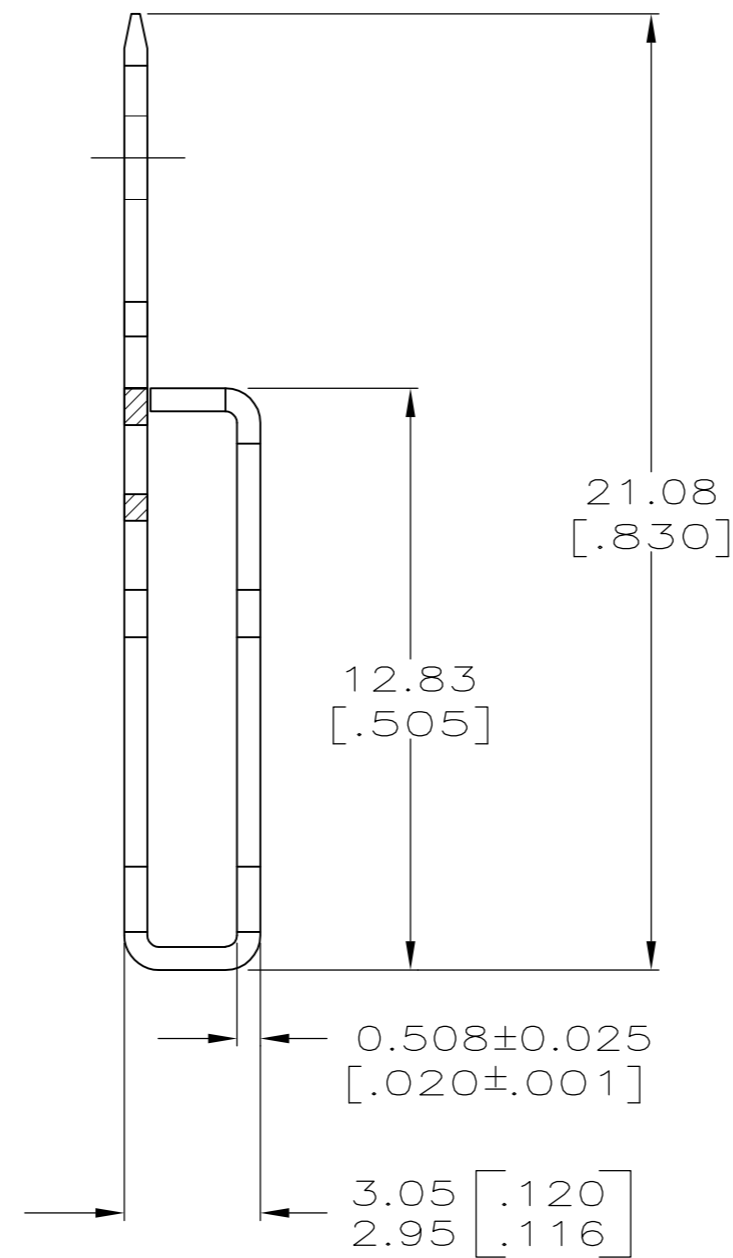
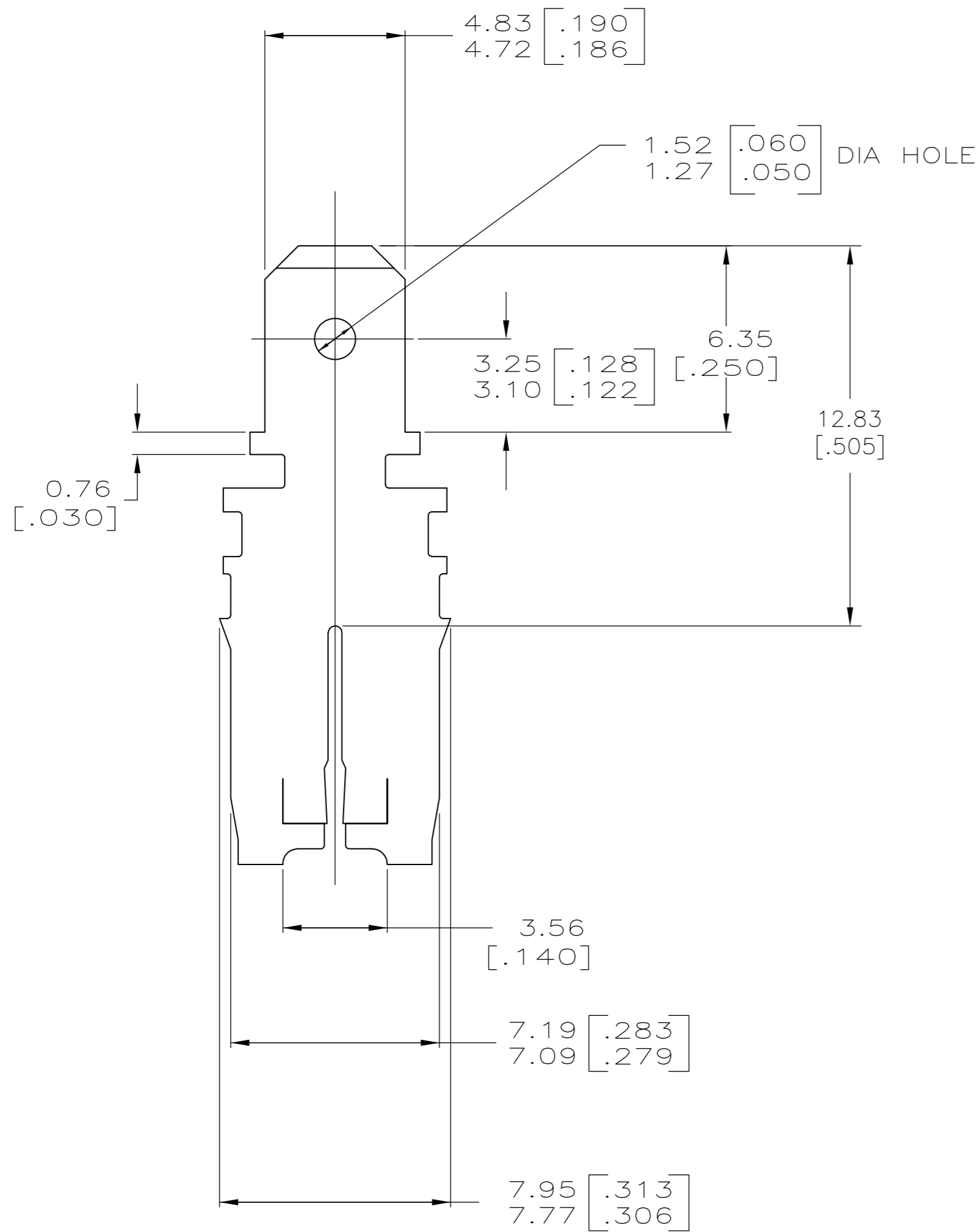

63708-1
PART NO.

THIS DRAWING IS A CONTROLLED DOCUMENT.		DWN MICHAEL S. FEHER 5/24/93														
DIMENSIONS: mm [INCHES]		CHK JEFF R. RUTH 6/2/93														
TOLERANCES UNLESS OTHERWISE SPECIFIED:		APVD NELSON E. NEFF 6/2/93	NAME TAB, LOOSE PIECE, 4.75 [.187] FASTON™, MAG-MATE™													
<table border="1"> <tr><td>0 PLC</td><td>± -</td></tr> <tr><td>1 PLC</td><td>± -</td></tr> <tr><td>2 PLC</td><td>± 0.25 [.010]</td></tr> <tr><td>3 PLC</td><td>± -</td></tr> <tr><td>4 PLC</td><td>± -</td></tr> <tr><td>ANGLES</td><td>± -</td></tr> </table>		0 PLC	± -	1 PLC	± -	2 PLC	± 0.25 [.010]	3 PLC	± -	4 PLC	± -	ANGLES	± -	PRODUCT SPEC 108-2053	SIZE A2	CAGE CODE 00779
0 PLC	± -															
1 PLC	± -															
2 PLC	± 0.25 [.010]															
3 PLC	± -															
4 PLC	± -															
ANGLES	± -															
MATERIAL BRASS		FINISH -3	APPLICATION SPEC 114-2066	DRAWING NO C-63708												
		WEIGHT -	SCALE 6:1	SHEET 1 of 1												
		CUSTOMER DRAWING	REV B1	RESTRICTED TO -												