



## NXP NX3L2G66 evaluation board

# Demonstrate the lossless switching of signals with a dual low ohmic SPST switch

Use this compact eval board to evaluate the NX3L2G66, a low-ohmic, dual single-pole single-throw (SPST) analog switch.

### Key features and benefits

- ▶ Wide supply voltage range (1.4 to 4.3 V) and low  $R_{on}$  ( $0.5 \Omega$  typ) for design flexibility
- ▶ High current handling capability (up to 350 mA continuous) for different load types
- ▶ Ideal for sensing and sampling applications with low leakage ( $<50$  nA at 85 °C)
- ▶ Overvoltage-tolerant control inputs, eliminating the need for an external voltage translator
- ▶ High off isolation of 90 dB for better protection of devices in circuit
- ▶ Ability to monitor the I/O rise/fall times and propagation delays with different loads (capacitors and resistors)
- ▶ Excellent ESD performance (7.5 kV HBM), suitable for consumer applications
- ▶ Available in very small 8-pin leadless XSON and XQFN packages for reduced PCB size
- ▶ Fully specified for use in harsh conditions ( $-40$  °C to 85 °C or 125°C)

Each switch in the NXP NX3L2G66 has two I/O terminals (nY and nZ) and an active HIGH enable input (nE). When pin nE is LOW, the analog switch is turned off.

Schmitt-trigger action at the enable input (nE) makes the circuit tolerant to slower input rise and fall times across the entire VCC range (1.4 V to 4.3 V). The NX3L2G66 allows signals with amplitude up to  $V_{CC}$  to be transmitted from nY to nZ or from nZ to nY. The low ON resistance ( $0.5 \Omega$ ) and flatness ( $0.13 \Omega$ ) ensure minimal attenuation and distortion of transmitted signals.



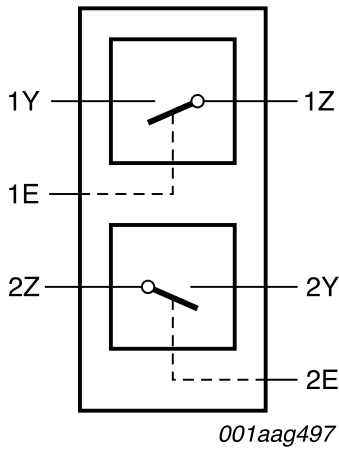

A supply voltage of 1.4 V to 4.3 V can be used for the board. Signals in the range of 0 V to  $V_{CC}$  can be connected to nZ pins and switched to nY pins or vice versa with minimal loss. The maximum input frequency for each of the two channels can be as high as 60 MHz at a load of  $50\ \Omega$ . By default, to avoid floating enable pins,  $1\ \text{k}\Omega$  pull-down resistors are connected between the 1E, 2E lines and GND, and both switches are OFF/ open. In order to turn a switch ON (close the contact), a logic HIGH signal needs to be connected to the associated Enable pin. Additional connectors (JP1 and JP2) with VCC and GND pins make it easy to connect the Enable pins and GND leads of an oscilloscope probe to the board. Also, to test variations in output rise and fall times at resistive and capacitive types of loads, the board supports loads of  $R1 = 500\ \Omega$ ,  $R2 = R4 = 4.7\ \text{k}\Omega$ , and  $C2 = 5.6\ \text{pF}$ .

Functional block diagram

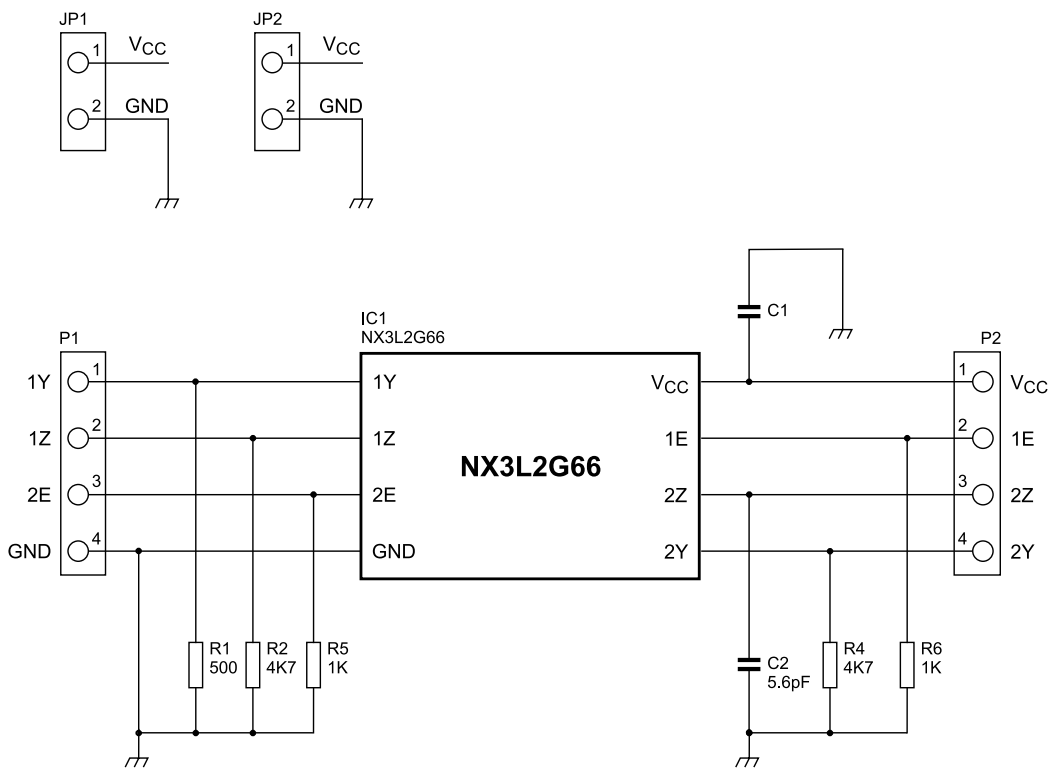

Circuit schematics of demo board

### Test results

The figures below present the results of tests done on the NX3L2G66 eval board. The purple waveform in Figure 1 is a 500 kHz square wave input with amplitude of 1.71 V applied at the 1Z pin, while the orange waveform is the switch output at 1Y pin with a load of 500  $\Omega$ , when Enable pin (1E) is pulled LOW and switch is OFF. Figure 2 shows the output at 1Y pin in the orange waveform, when Enable pin (1E) is connected to a switch supply voltage VCC of 3 V.

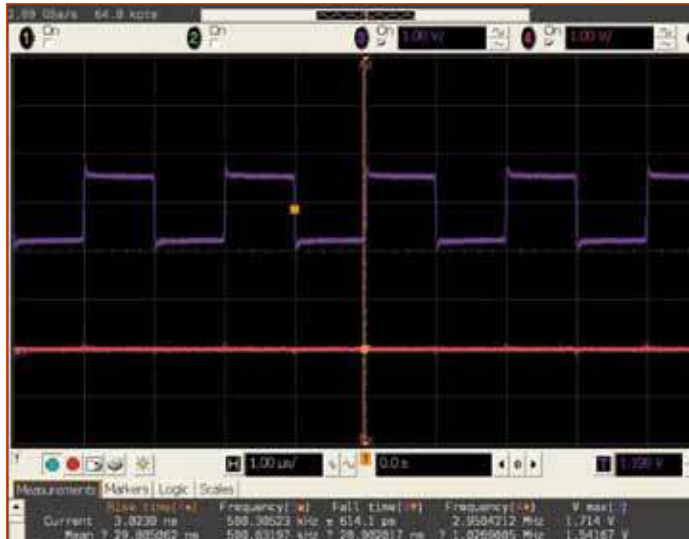

Figure 1

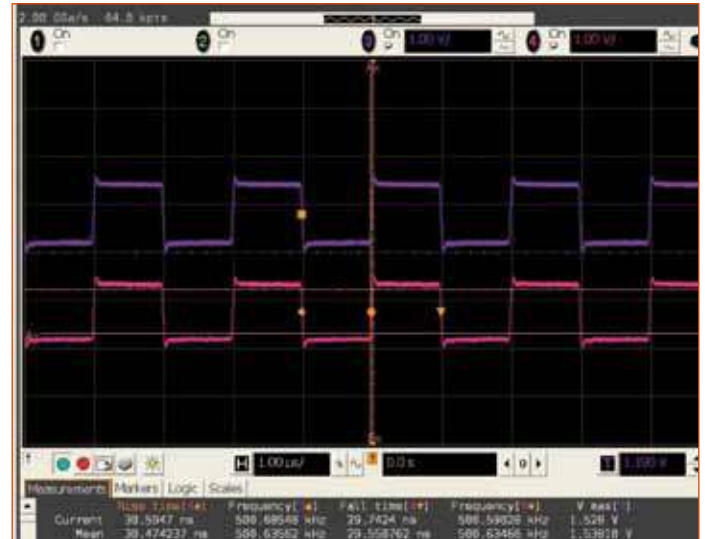

Figure 2

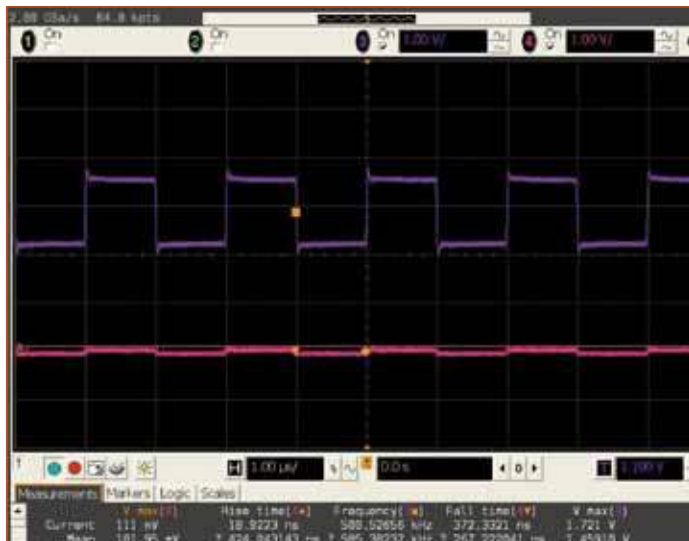

Figure 3

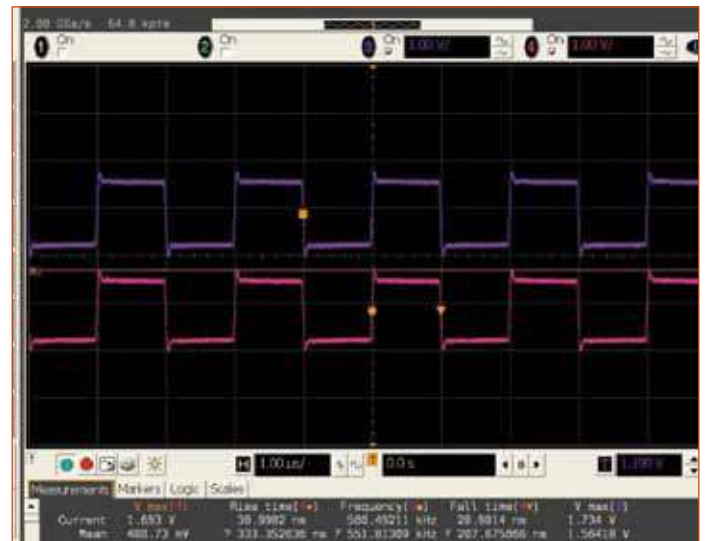

Figure 4

Figures 3 and 4 show the same test results for pins 2Y (used as input) and 2Z (used as output) but the output load is changed to 5.6 pF. Again, the purple waveforms in Figures 3 and 4 show the input signals and the orange waveforms show the switch output signals. Note that there is minimal loss in signal amplitude at the input and output terminals of each switch. Also, there is minimal change in the output rise and fall times and the frequency of the input and output signals at resistive and capacitive loads.

## Packages

Package suffix	GT	GD	GM
			
	SOT833-1	SOT996-2	SOT902-1
	8-pin	8-pin	8-pin
Width (mm)	1.0	2	1.65
Length (mm)	1.95	3	1.65
Height (mm)	0.5	0.5	0.5
Pitch (mm)	0.5	0.5	0.5

## Ordering information

Part number	Package				
	Temp. range	Name	Type	Marking	Material
NX3L2G66GT	-40 to 125°C	XSON8	Extremely thin small outline package; no leads	D66	Plastic
NX3L2G66GD	-40 to 125°C	XSON8U	Extremely thin small outline package; no leads	D66	Plastic
NX3L2G66GM	-40 to 125°C	XQFN8U	Extremely thin quad flat package; no leads	D66	Plastic