

THE INFORMATION CONTAINED HEREIN IS CONSIDERED "PROPRIETARY" TO BEL FUSE INC. AND SHALL NOT BE COPIED, REPRODUCED OR DISCLOSED WITHOUT THE WRITTEN APPROVAL OF BEL FUSE INC.

LED1 POLARITY			LED2 POLARITY		
PIN 17	PIN 18	COLOR	PIN 19	PIN 20	COLOR
-	+	YELLOW	-	+	GREEN



ELECTRICAL CHARACTERISTICS @ 25°C

URNS RATIO

TP1	1CT : 1CT ±2%
TP2	1CT : 1CT ±2%
TP3	1CT : 1CT ±2%
TP4	1CT : 1CT ±2%

OCL @ 100kHz/100mVRMS

FOR CHANNEL 1, CHANNEL 2

8mA DC BIAS	350µH MIN.
19mA DC BIAS	120µH MIN.

FOR CHANNEL 3, CHANNEL 4

8mA DC BIAS	350µH MIN.
-------------	------------

INS. LOSS

0.1MHz TO 1MHz	-1.1 dB MAX
1MHz TO 65MHz	-0.8 dB MAX
65MHz TO 100MHz	-1.0 dB MAX
100MHz TO 125MHz	-1.2 dB MAX

RET. LOSS (MIN)

0.5MHz-40MHz	-18 dB
40MHz-100MHz	-12+20LOG(f/80MHz) dB

CM TO CM REJ

100kHz - 100MHz	-30 dB MIN
-----------------	------------

CM TO DM REJ

100kHz - 100MHz	-35 dB MIN
-----------------	------------

HIPOT (Isolation Voltage): 2250 VDC

100% OF PRODUCTION TESTED TO COMPLY WITH IEEE 802.3 ISOLATION REQUIREMENTS.

LED 1

VF (FORWARD VOLTAGE) IF=20mA YELLOW 2.1V TYP.
 λD (DOMINANT WAVELENGTH) IF=20mA YELLOW 590nm TYP.

LED 2

VF (FORWARD VOLTAGE) IF=20mA GREEN 2.2V TYP.
 λD (DOMINANT WAVELENGTH) IF=20mA GREEN 570nm TYP.

BALANCED DC LINE CURRENT 600mA MAX CONTINUOUS

1.2A MAX. FOR 200 MILLISECONDS

OPERATING TEMPERATURE: -40°C TO 85°C

SCHEMATIC

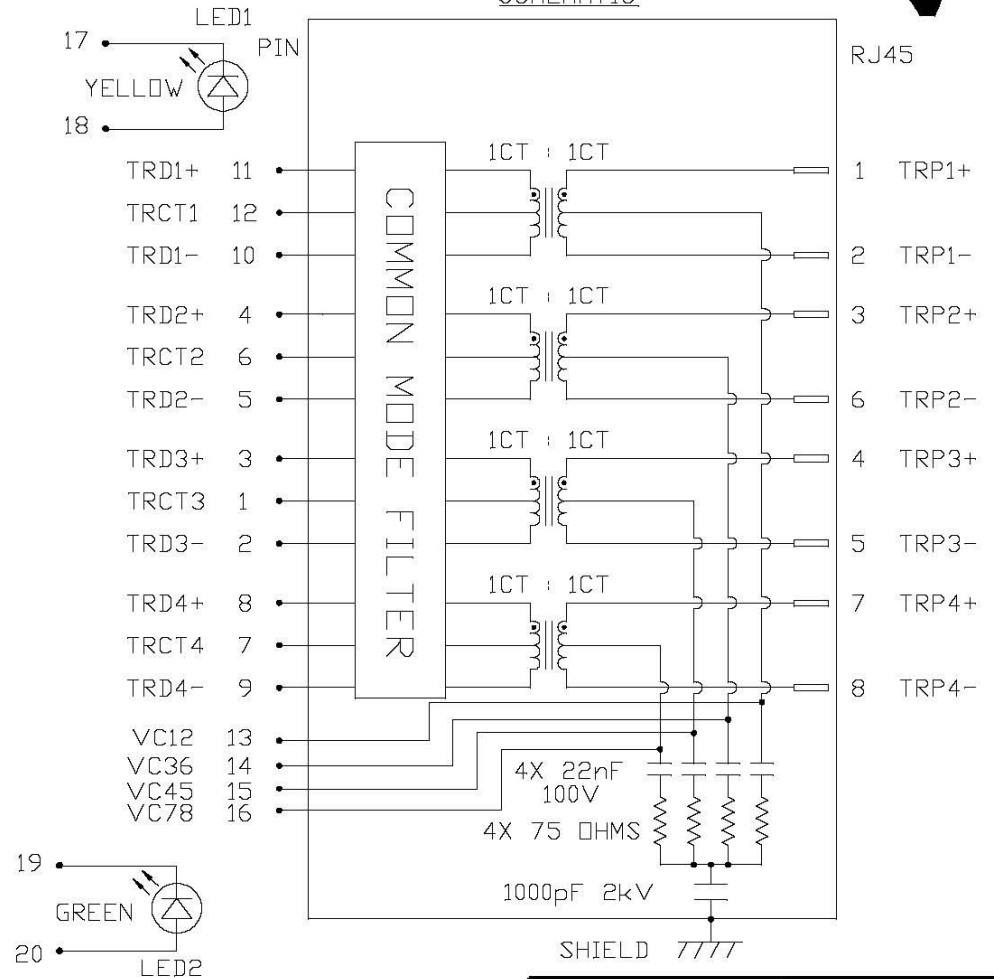

ORIGINATED BY
 CHOW WANCHUNG
 DATE 2020-08-07
 DRAWN BY
 XIE YIMING
 DATE 2020-08-07

TITLE
 gigabit MagJack®
 Vertical, 4PPoE
 PATENTED

PART NO. / DRAWING NO.
 V8BR-1AX1-GH
 FILE NAME
 V8BR-1AX1-GH_PC.DWG

STANDARD DIM. TOL. IN INCH	[] METRIC DIM. AS REF.
.X	UNIT : INCH [mm]
.XX	SCALE : N/A
.XXX	SIZE : A4

REV. : PC PAGE : 2



THE INFORMATION CONTAINED HEREIN IS CONSIDERED "PROPRIETARY" TO BEL FUSE INC, AND SHALL NOT BE COPIED, REPRODUCED OR DISCLOSED WITHOUT THE WRITTEN APPROVAL OF BEL FUSE INC.

MECHANICAL SPECIFICATION

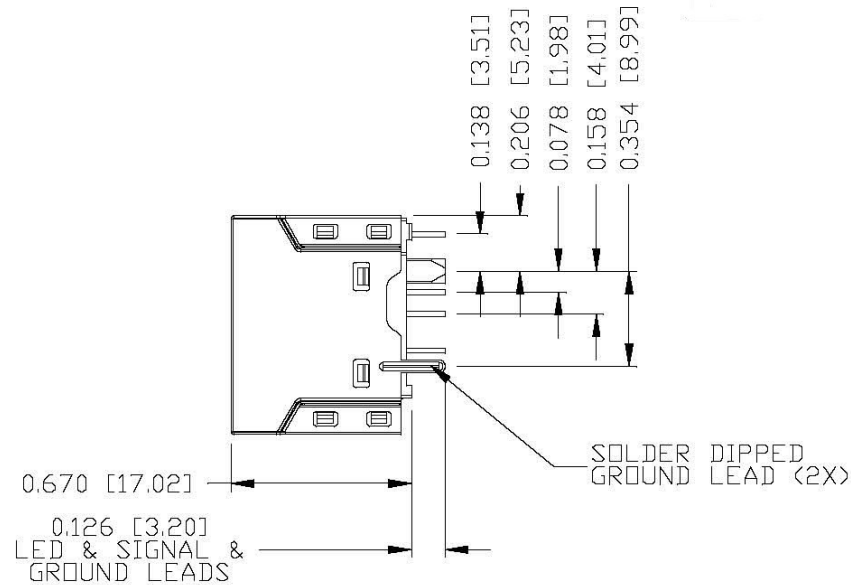
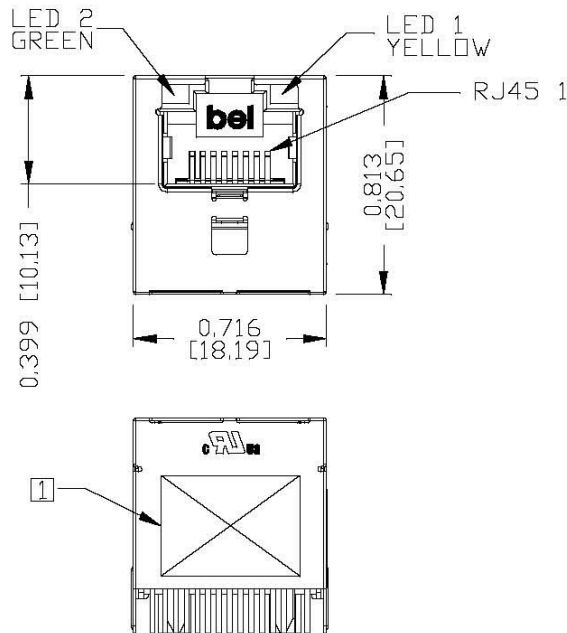

NOTES:

- PLASTIC HOUSING: THERMOPLASTIC PBT, BLACK
FLAMMABILITY RATING UL 94V-0
- CONTACT PLATING: 30 MICRO-INCH HARD GOLD PLATING OR EQUIVALENT
- OUTPUT PINS: TIN-COATED COPPER WIRE, DIA 0.018 INCH.
100 MICRO-INCH MIN MATTE TIN.
PINS ARE SOLDER DIPPED.
- METAL SHIELD: STAINLESS STEEL
(ALL GROUND LEADS ARE SOLDER DIPPED)

JACK CAVITY CONFORMS TO FCC RULES AND REGULATIONS.

1. MARK PART WITH MFG LOGO, MFG NAME, PART NUMBER, DATE CODE AND PATENTED.
2. THE PRODUCT IS ROHS COMPLIANT.
3. THE PRODUCT IS PATENTED, THE PATENT NUMBER ARE U.S. PAT 6,840,817 & U.S. PAT. 7,123,117.
4. THE PART IS RECOMMENDED FOR WAVE SOLDERING. THE SUGGESTED PEAK WAVE SOLDERING CONDITION IS 260°C MAX. AND 10 SECONDS MAX..

ORIGINATED BY
LI QUANKUN
DATE 2020-08-07

DRAWN BY
OLIVER ZHANG
DATE 2020-08-07

TITLE
glgabit MagJack®
Vertical, 4PPoE
PATENTED

PART NO. / DRAWING NO.
V8BR-1AX1-GH

FILE NAME
V8BR-1AX1-GH_PC.DWG

STANDARD DIM. TOL. IN INCH		[] METRIC DIM. AS REF.
.X		UNIT : INCH [mm]
.XX		SCALE : N/A
.XXX	±0.010	SIZE : A4

REV. : PC PAGE : 3



THE INFORMATION CONTAINED HEREIN IS CONSIDERED "PROPRIETARY" TO BEL FUSE INC. AND SHALL NOT BE COPIED, REPRODUCED OR DISCLOSED WITHOUT THE WRITTEN APPROVAL OF BEL FUSE INC.

RoHS

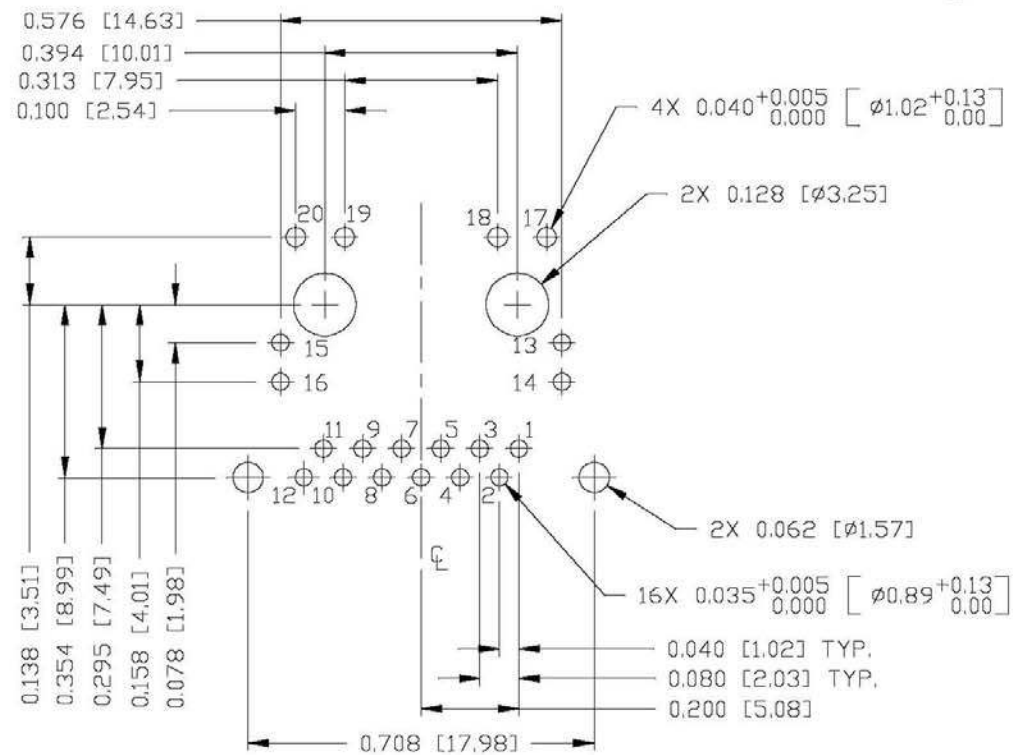
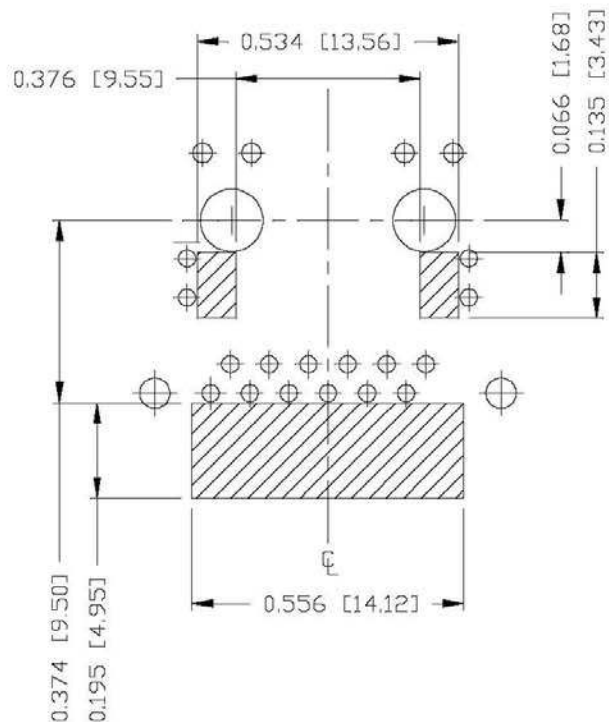

RECOMMENDED PCB FOOTPRINT
COMPONENT SIDE VIEW

NOTES
THE SHADED AREA ON THE CUSTOMER BOARD ARE RECOMMENDED TO BE CLEAR OFF ANY VIA HOLE OR COMPONENT PAD.

ORIGINATED BY LI QUANKUN DATE 2020-08-07		TITLE gigabit MagJack® Vertical, 4PPoE PATENTED	PART NO. / DRAWING NO. V8BR-1AX1-GH		STANDARD DIM. [] METRIC DIM. TOL. IN INCH AS REF.		REV. : PC PAGE : 4
DRAWN BY OLIVER ZHANG DATE 2020-08-07			FILE NAME V8BR-1AX1-GH_PC.DWG		.X	UNIT : INCH [mm]	
					.XX	SCALE : N/A	
				.XXX	±0.004	SIZE : A4	

DC002(2)120214

This document is electronically generated. This is a controlled copy if used internally

THE INFORMATION CONTAINED HEREIN IS CONSIDERED 'PROPRIETARY' TO BEL FUSE INC. AND SHALL NOT BE COPIED, REPRODUCED OR DISCLOSED WITHOUT THE WRITTEN APPROVAL OF BEL FUSE INC.

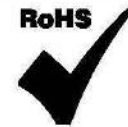

SUGGESTED PANEL OPENING

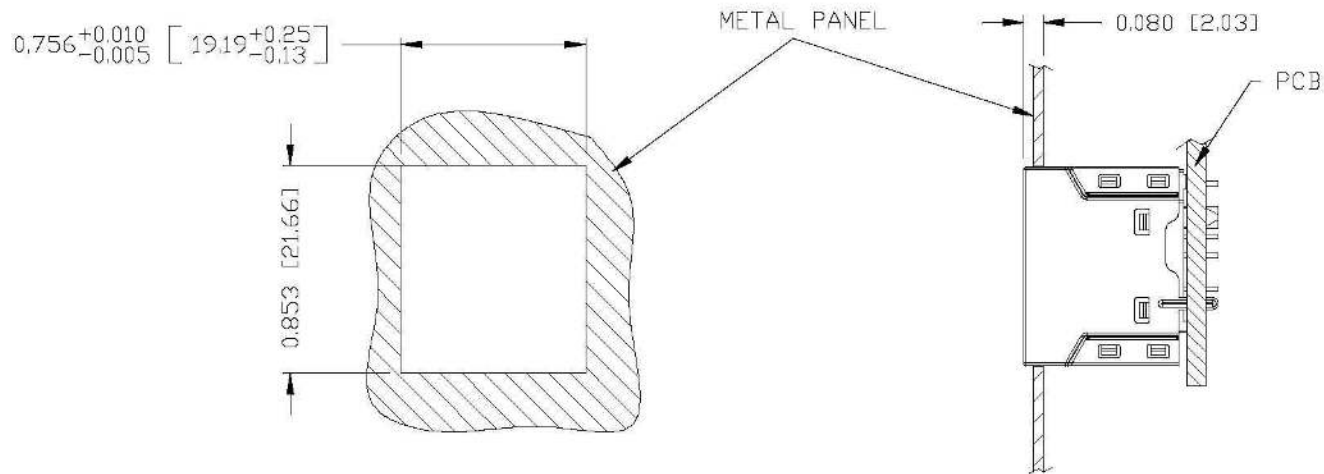

NOTES:

THE DISTANCE OF PANEL INSIDE SURFACE RELATIVE TO FRONT SURFACE OF PART IS ONLY A SUGGESTION. IN CASE THIS DISTANCE IS DIFFERENT, THE REQUIRED PANEL OPENING DIMENSIONS CHANGE ACCORDINGLY.

PACKING INFORMATION

PACKING TRAY : 0200M9999-T1(TOP)

0200M9999-T0(BOTTOM)

PACKING QUANTITY : 50 PCS FINISHED GOODS PER TRAY

9 TRAYS (450 PCS FINISHED GOODS) PER CARTON BOX

NOTER: CARDBOARDS ARE PLACED BETWEEN LAYERS OF PACKING TRAY INSIDE CARTON BOX (INCLUDE THE UPPERMOST AND LOWERMOST TRAY)

ORIGINATED BY LI QUANKUN DATE 2020-08-07		TITLE gigabit MagJack® Vertical, 4PPoE PATENTED	PART NO. / DRAWING NO. V8BR-1AX1-GH		STANDARD DIM. [] METRIC DIM. TOL. IN INCH AS REF.		REV. : PC	PAGE : 5
DRAWN BY OLIVER ZHANG DATE 2020-08-07			FILE NAME V8BR-1AX1-GH_PC.DWG		.X	UNIT : INCH [mm]		
					.XX	SCALE : N/A		
				.XXX	40.005	SIZE : A4		