

ADA compliant, tactile keypad for audible system navigation

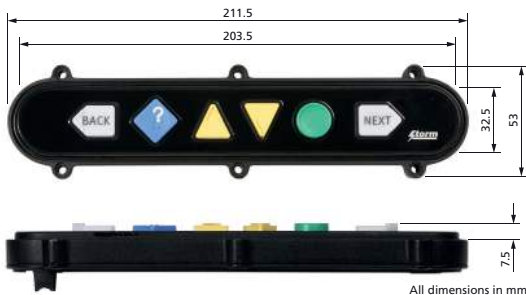

Storm Assistive Technology Products provide improved accessibility for those with impaired vision, restricted mobility or limited fine motor skills.

Self-service terminals usually present information about available products or services via an electronic display or touch screen. Presentation of information in this exclusively visual format discriminates against those with impaired vision or reading difficulties. NavBar™ is a highly tactile interface that makes audio navigation and selection of screen based menus possible. Audible descriptions of available menu options are communicated to the user through a personal headset, handset or cochlea implant. Menus can be navigated and selections made by pressing distinctively shaped tactile keys.



The version shown above is designed for under-panel installation. A surface mounted version is also available. Successful implementation of the NavBar™ requires a compliant host application featuring synthesized or recorded human voice audio content.

NavBar™ was developed in association with the Trace Research & Development Center with support from the University of Wisconsin. NavBar™ is a compliant tactile interface device for use as part of an ADA audible menu navigation system or EZ-Access® implementation.

- Space efficient horizontal format for use with contemporary touch-screen kiosks.
- Audible references to a key's position and function are easier to understand. For example: 'The circular shaped 'select' key is the second key from the right'.
- Distinctive keytop shapes and tactile symbols help to identify each key's specific function.
- Colour coded keys make identification of key function easier for those with partial vision.
- NavBar™ can be specified in fully illuminated or partially illuminated configurations.
- The intensity of keytop illumination can be adjusted or turned off when not in use.
- Illuminated keytops are lit by a dedicated LED light source. Each LED is independently controllable.
- The NavBar™ utility software, allows the default illumination status and device 'wake-up' behaviour to be configured. USB key-press codes and default sound volume settings can also be changed.
- The optional Audio Module features accessible sound volume controls and an illuminated jack plug socket for headset connection. (Audio Module supplied separately).
- The Audio Module can be positioned separately from the NavBar™ to optimize system ergonomics and accessibility.
- Audio Module is connected to the NavBar™ via a ribbon cable (supplied).
- NavBar™ is connected to the host system via a single USB cable (supplied separately).

Storm, Storm ATP, Storm Interface, NavBar and Audio Module are trademarks of Keymat Technology Ltd. All rights reserved. EZ Access® is a trademark of the Wisconsin Alumni Research Foundation.

Environmental

Vibration & Shock:
Impact Resistance:

ETSI 6M3
IK09 (10J Rating)
(when correctly installed to a panel)

Sealing:

IP65 (when correctly installed to a panel)

Operational temperature:

-20°C to +70°C (dry)

Weather Resistance:

IP65 (when panel mounted)

Performance

Operational Key Life:

>4 million cycles per key

Certification:

CE / FCC / UL

Specification

Rating:

5V +/- 0.25V (USB 2.0)

Connection:

Mini USB B Socket

Audio:

3.5mm Audio Jack Socket (Illuminated)

Ground:

150mm ESD ground wire fitted to Audio Module

USB Cable

Not included

Interconnect Cable

0.75m cable (NavBar to Audio Module) included with Audio Module



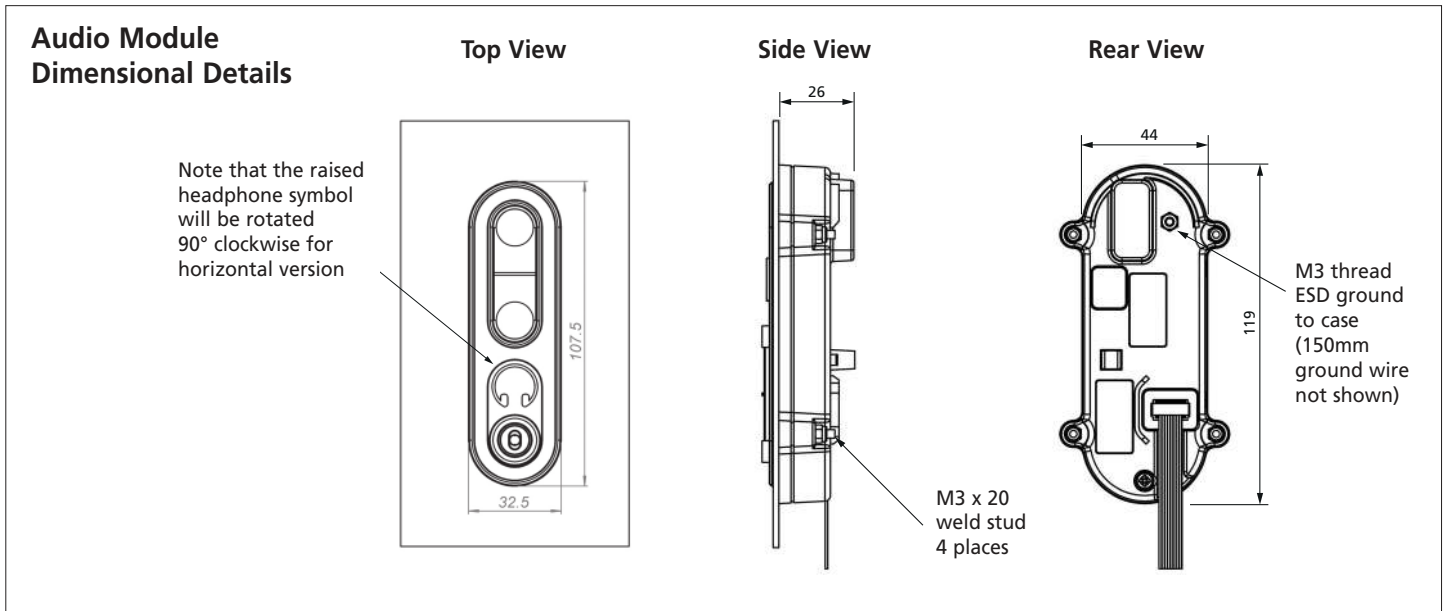
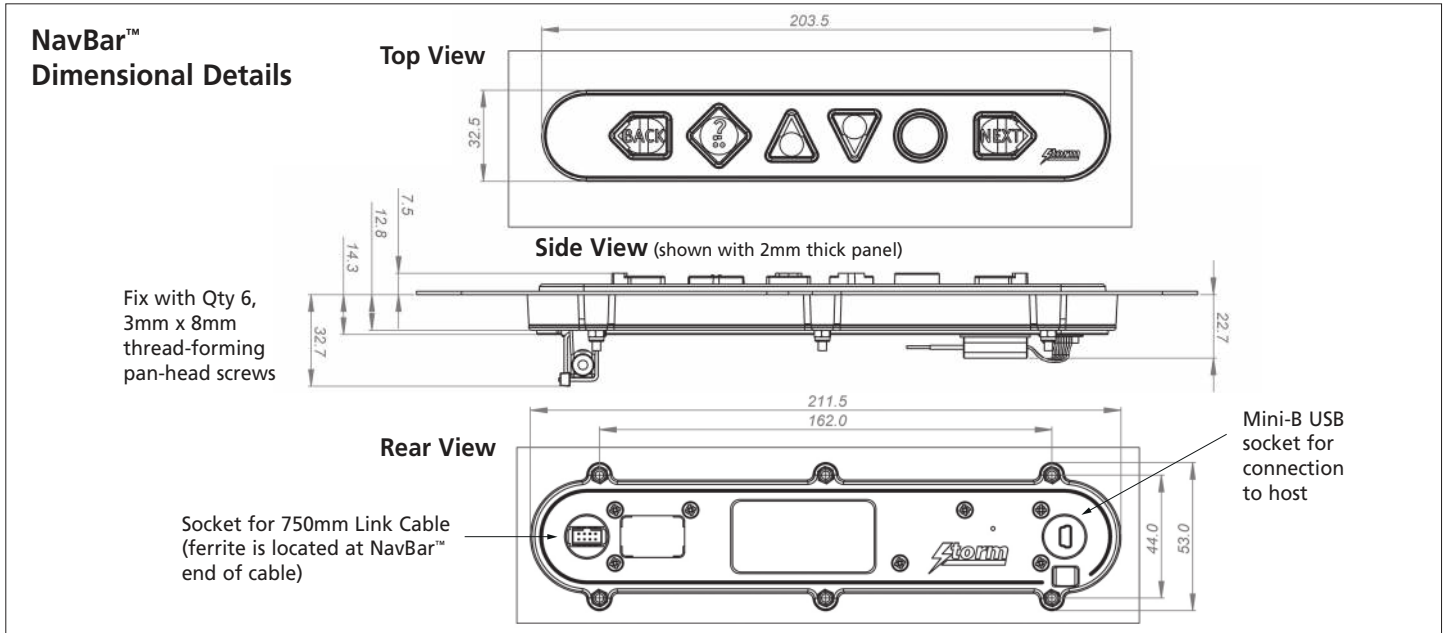

Part Numbers

NavBar™ Silver with White Keys (fully illuminated), Surface Mount	EZB6-43000
NavBar™ Silver with White Keys (fully illuminated), Under-panel	EZB6-43002
NavBar™ Black with White Keys (fully illuminated), Surface Mount	EZB6-53000
NavBar™ Black with White Keys (fully illuminated), Under-panel	EZB6-53002
NavBar™ Silver with Coloured Keys (partially illuminated), Surface Mount	EZB6-73000
NavBar™ Silver with Coloured Keys (partially illuminated), Under-panel	EZB6-73002
NavBar™ Black with Coloured Keys (partially illuminated), Surface Mount	EZB6-63000
NavBar™ Black with Coloured Keys (partially illuminated), Under-panel	EZB6-63002
Audio Module (Vertical) Silver, Interconnect Cable	EZB2-40500
Audio Module (Horizontal) Silver, Interconnect Cable	EZB2-405H0
Audio Module (Vertical) Black, Interconnect Cable	EZB2-50500
Audio Module (Horizontal) Black, Interconnect Cable	EZB2-505H0

Accessories

Spare Interconnect Cable, 0.75m	EZB2-01
USB Cable, Mini-B to Type A, 0.9m	4500-01



Whilst every effort is made to ensure details are correct at time of print, specifications are subject to change without notice.

For more information & to order:
www.storm-interface.com

Storm Interface products include technology protected by international patents and design registration. All rights reserved.
 Storm is a trademark of Keymat Technology Ltd. Storm Interface is a trading name of Keymat Technology Ltd.

NavBar UPM Aug 2017
 Designed & produced by NIK Design Ltd
www.nikdesign.co.uk

FM 39602

