

PRODUCT NO
SEE SHEET 2

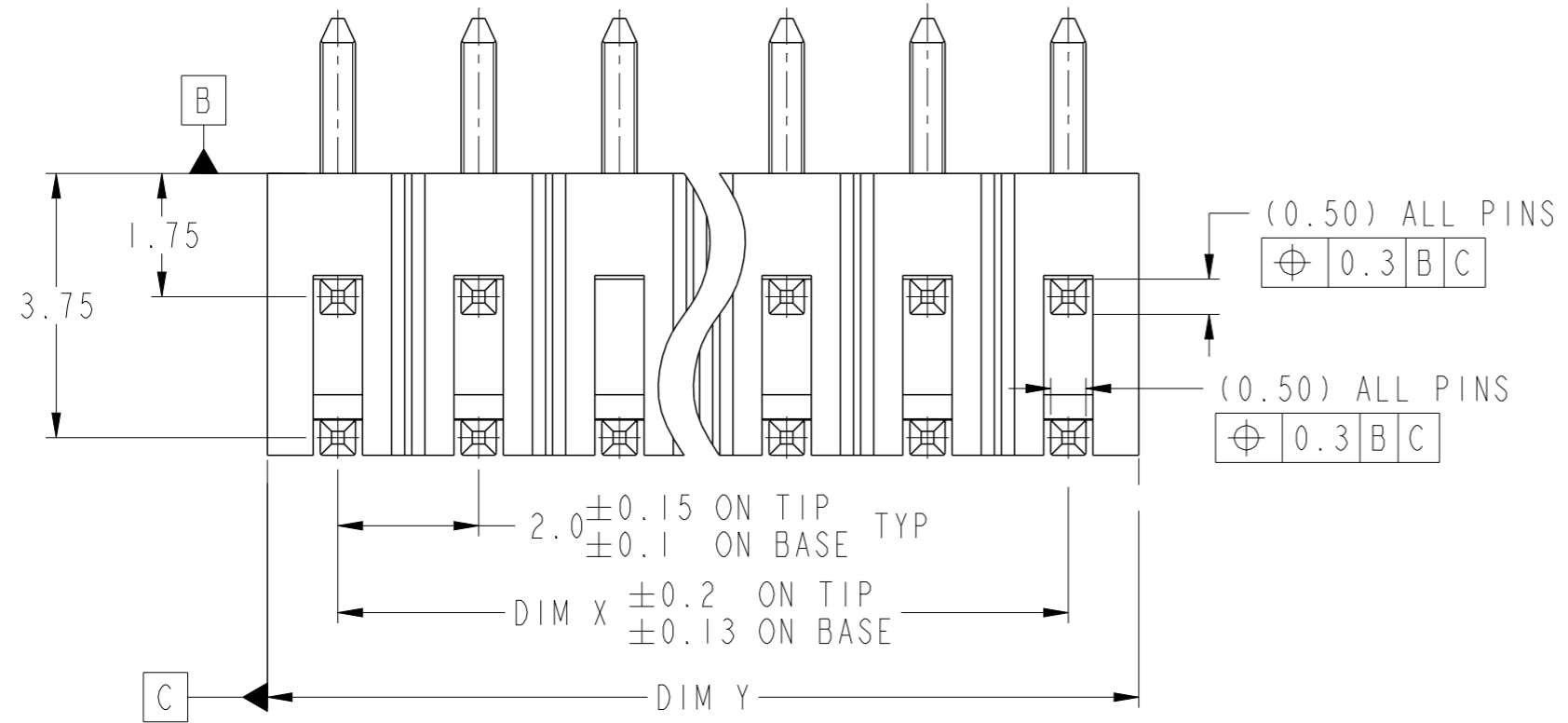
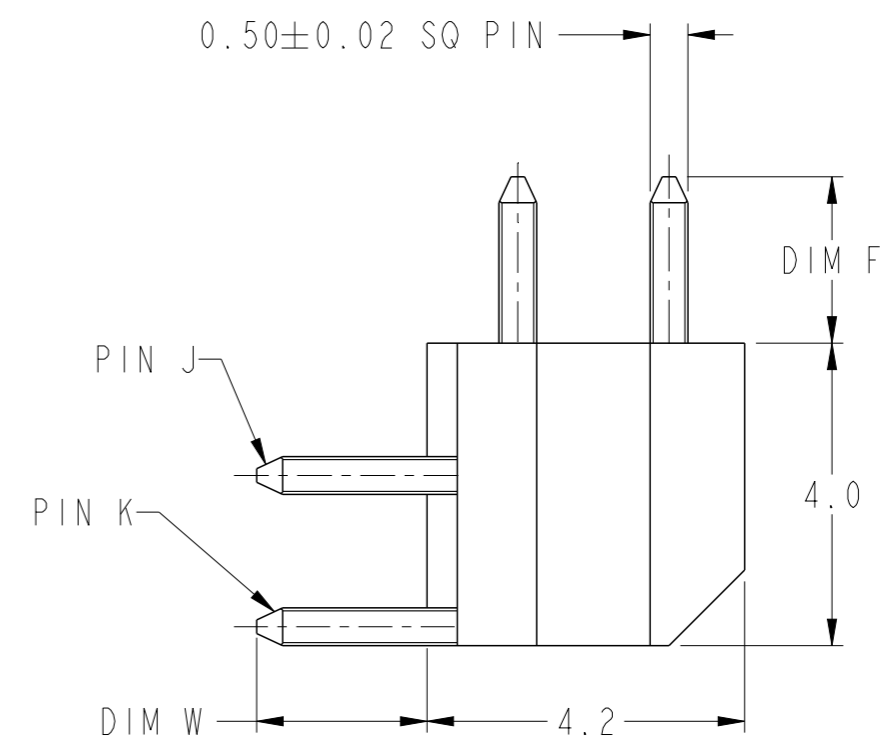
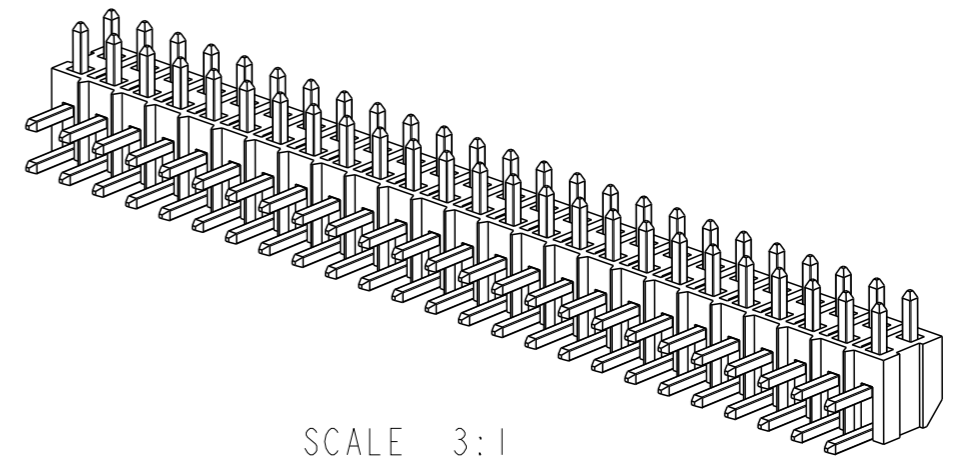
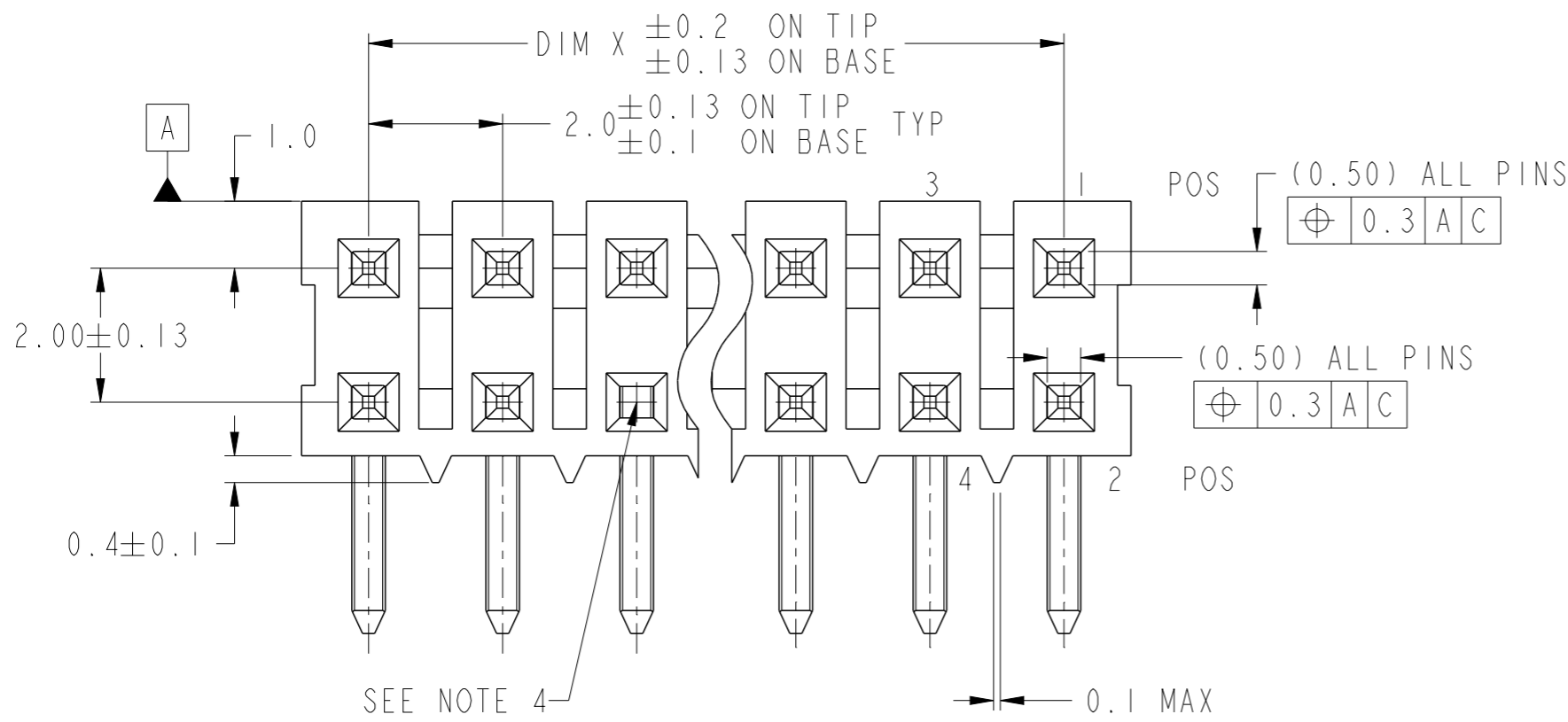

Copyright FCI.
FCI

spec ref	-	dr	Andrew Yong	2010/12/29	projection	MM	size	A3	scale	10:1	
tolerance std	ISO 406 ISO 1101	eng	Guo-Min Sun	2014/08/27		← →	ecn no	ELX-N-18666-1			
TOLERANCES UNLESS OTHERWISE SPECIFIED		chr	-	-			product family	MINITEK	rel level	Released	
surface	✓	appr	Rick Bian	2014/08/27	DIM W		dwg no	10115395		rev	B
ISO 1302	linear	0.X	± -		MINITEK II		cat. no.	Product - Customer Drw		sheet 1 of 3	
	0.XX	± 0.25	R/A HEADER								
	0.XXX	± -									
	angular	0°	± °	www.fci.com	PDS: Rev :B		STATUS:Released		Printed: Aug 27, 2014		

PRODUCT NO SEE NOTES 5, 9 & 10.	POS	POL. POS	DIM X	DIM Y	DIM F	DIM W	PLATING
10115395-001TRLF	2X25	-	48	50	2.4	2.2 ±0.13	2.54-5.08µm MATTE TIN OVER Ni

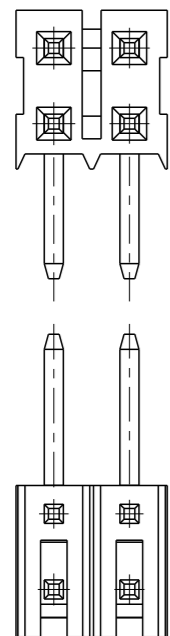
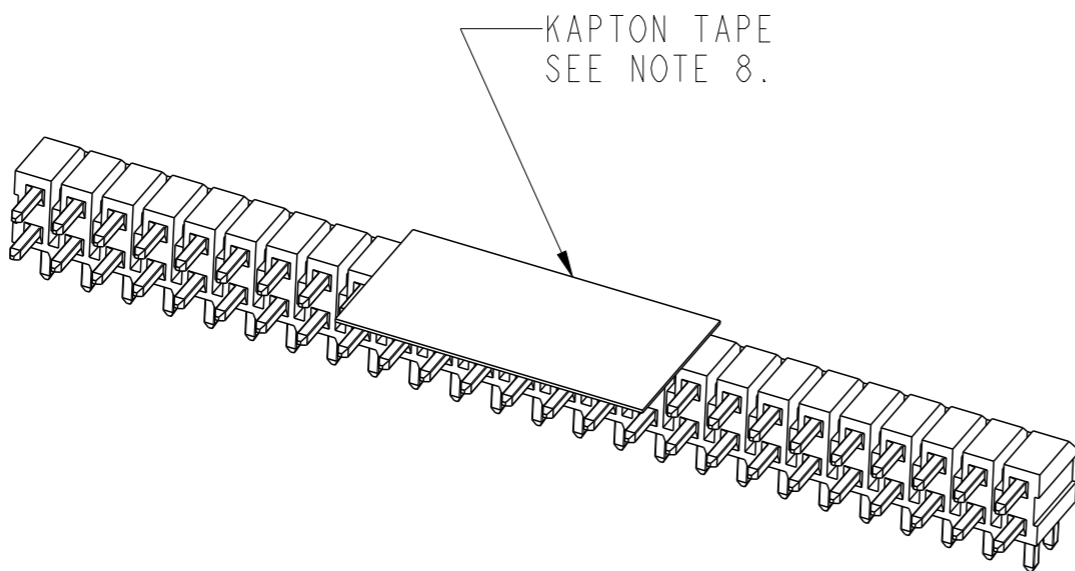
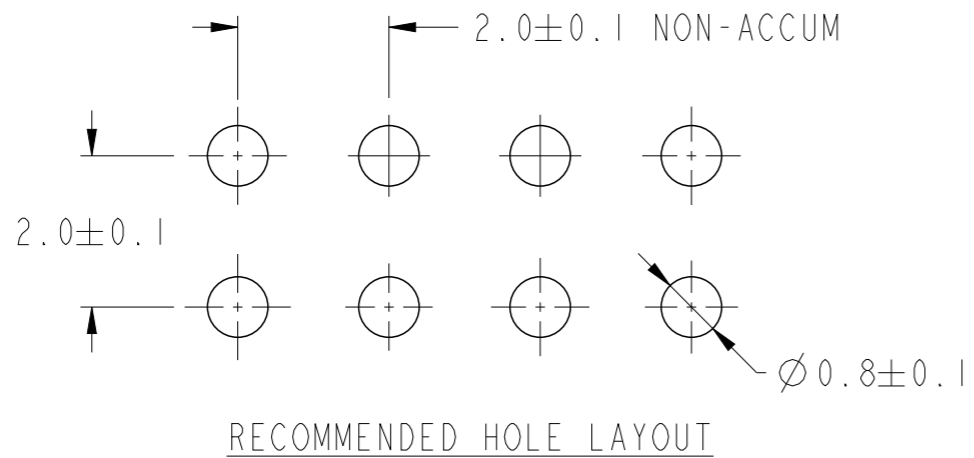

FIG. 1
SEE NOTE 3

NOTES:

- MATERIAL:
BODY : HIGH TEMPERATURE PLASTIC UL 94V-0 BLACK
PIN : COPPER ALLOY
- TOLERANCE UNLESS OTHERWISE NOTED ±0.25
- STAND-OFF DESIGN FOR 2X2 POS. REFERS TO FIG. 1.
- POLARISED BY OMISSION OF PINS. REFER TO TABLE FOR POSITION.
- 10115395-XXXLF IS SAME TO 10115395-XXX. THE 'LF' IS ADDED JUST FOR EASY LEAD FREE IDENTIFICATION
- THE HOUSING WILL WITHSTAND EXPOSURE TO 255°C PEAK TEMPERATURE FOR 10 SECONDS IN A CONVECTION, INFRA-RED OR VAPOR PHASE REFLOW OVEN.
- THE HOUSING WILL WITHSTAND EXPOSURE TO 260°C PEAK TEMPERATURE FOR 10 SECONDS IN A WAVE SOLDERING APPLICATION WITH A 1.57MM MINIMUM THICK CIRCUIT BOARD.
- KAPTON TAPE (10114546-002) DIMENSIONS: (6 X 15 X 0.125 mm). APPLY KAPTON TAPE TO THE CENTRE OF THE CONNECTOR.
- 'TR'- TAPE & REEL PACKAGING USED FOR THIS PRODUCT, DETAILS AS SPECIFIED IN PAGE 3 & 4.
- THIS PRODUCT MEETS EUROPEAN UNION DIRECTIVES AND OTHER COUNTRY REGULATIONS AS DESCRIBED IN GS-22-008.
- A \triangle SYMBOL WILL BE NEXT TO ANY DIMENSION, VIEW OR NOTE WHICH HAS BEEN MODIFIED WITH THE CURRENT DRAWING REVISION.

spec ref	-	dr	Andrew Yong	2010/12/29	projection	MM	size	A3	scale	10:1
tolerance std	ISO 406 ISO 1101	eng	Guo-Min Sun	2014/08/27			ecn no	ELX-N-18666-1		
surface	✓	chr	-	appr			Rick Bian	2014/08/27	product family	MINITEK
		linear	0.X	±-			dwg no	10115395		
		angular	0°	±°			cat. no.	-	Product - Customer Drw	sheet 2 of 3

PACKAGING SPEC

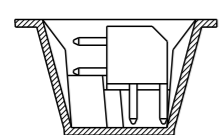
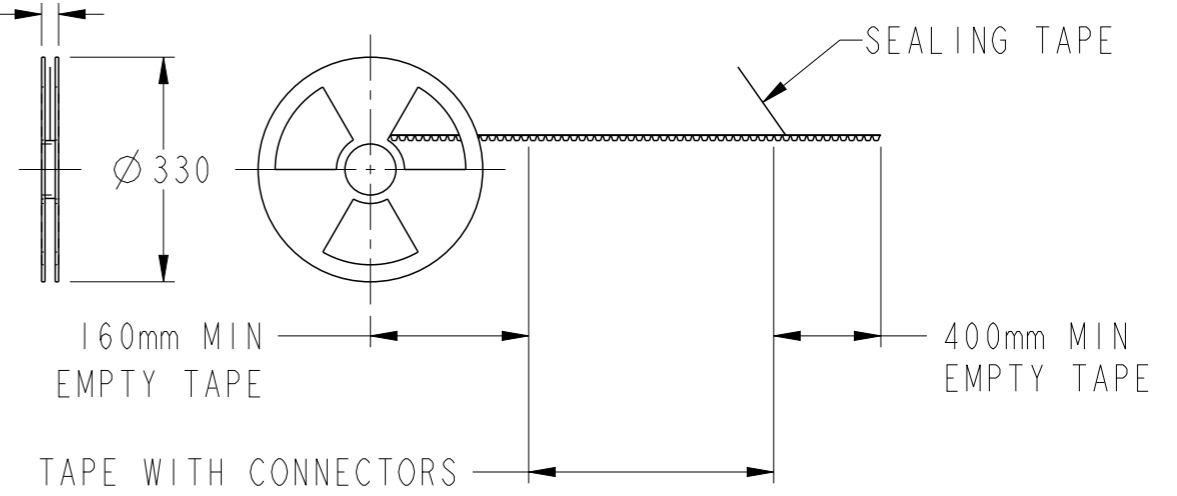
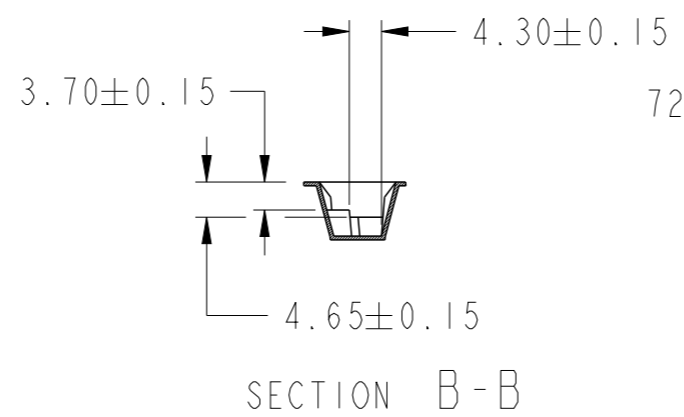
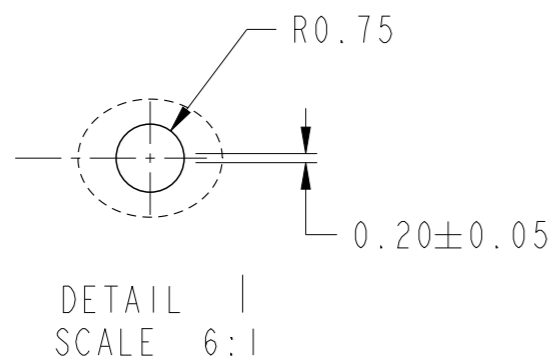
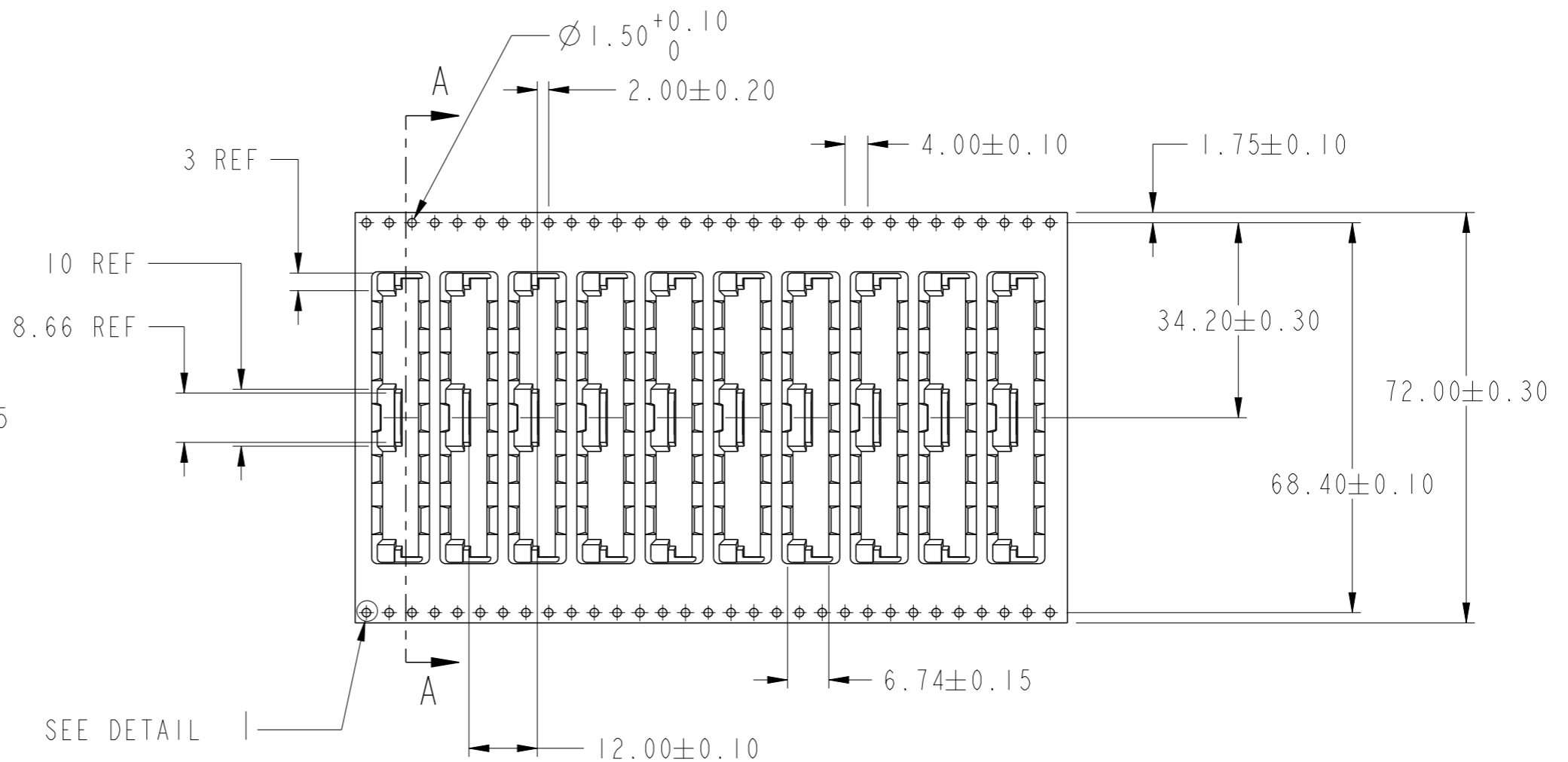
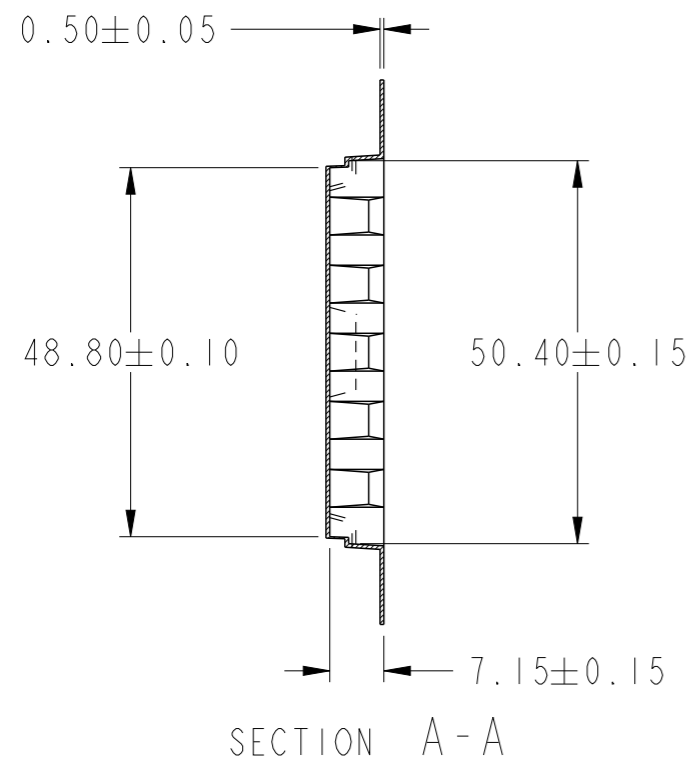

SCALE 2:1
PART INSIDE CARRIER TAPE

spec ref	-	dr	Andrew Yong	2010/12/29	projection	MM	size	A3	scale	1:1	
tolerance std	ISO 406 ISO 1101	eng	Guo-Min Sun	2014/08/27			ecn no	ELX-N-18666-1			
	TOLERANCES UNLESS OTHERWISE SPECIFIED	chr	-				rel level	Released			
surface	ISO 1302	appr	Rick Bian	2014/08/27	product family	PACKAGING	dwg no	10115395		rev	B
	linear				www.fci.com	cat. no.	-	Product - Customer Drw	sheet 3 of 3		
	angular										