

APPROVED: _____

DATE: _____ TITLE: _____

DE09-HD-PX-TS

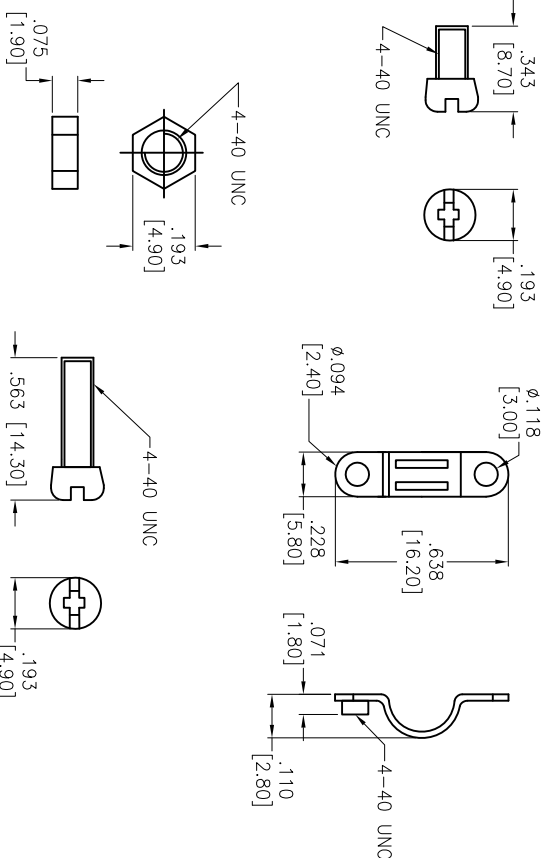
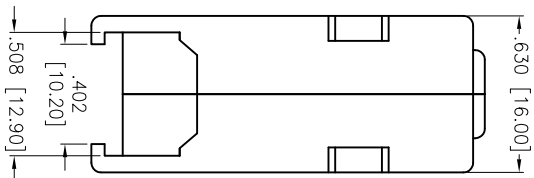
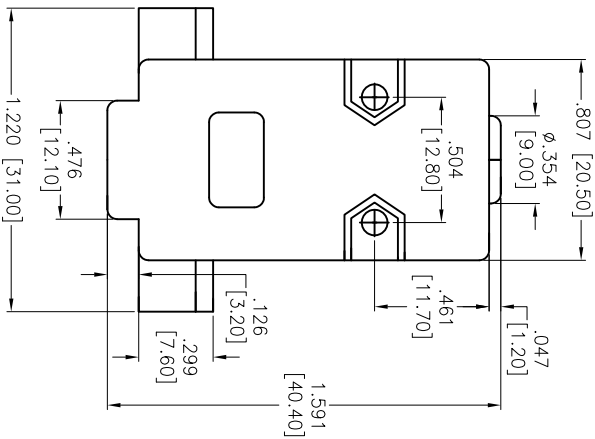
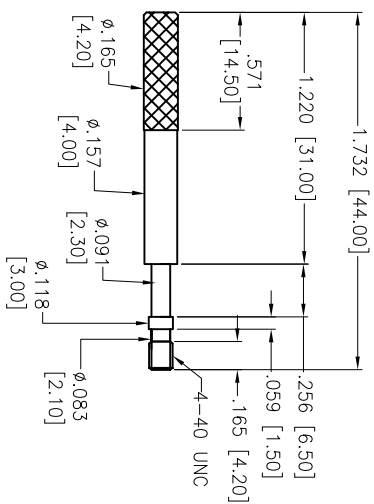
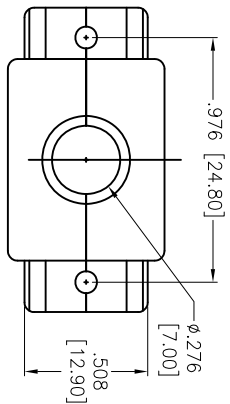

SPECIFICATIONS:
 Material:
 Insulator: ABS, rated UL 94HB
 Hardware color: Black
 Hardware: Steel, Chromate plated
 Environmental:
 Lead free, RoHS compliant

ADAM P/N	HOOD COLOR
DXXX-HD-PB-TS	BLACK PLASTIC
DXXX-HD-PN-TS	CHROME PLASTIC
DXXX-HD-PY-TS	GRAY PLASTIC



UNLESS OTHERWISE SPECIFIED ALL DIMENSIONS ARE INCHES [MM]	
TOLERANCES EXCEPT AS NOTED	
INCHES	
.X	± .10
.XX	± .020
.XXX	± .015
.XXX	± .015
.XXX	± .010
APPROVALS	
DATE	
DATE	

ADAM TECH	
909 Railway Avenue, Union, NJ 07083	
Phone: 908-687-5000 Fax: 908-687-5710	
TITLE: D-SUB HOOD, THUMB SCREWS	
SIZE	PART NO.
X	DXXX-HD-PX-TS
REF:	SCALE: NTS
S00064T	SHEET 1 OF 5

Rev	AWO #	Description	Date	Appr
-		RELEASED	5/22/15	

6

5

4

3

2

1

Rev	AWO #	Description	Date	Appr
		SEE SH1 1 OF 2 FOR REVISION		

APPROVED: _____

DATE: _____ TITLE: _____

DA15-HD-PX-TS

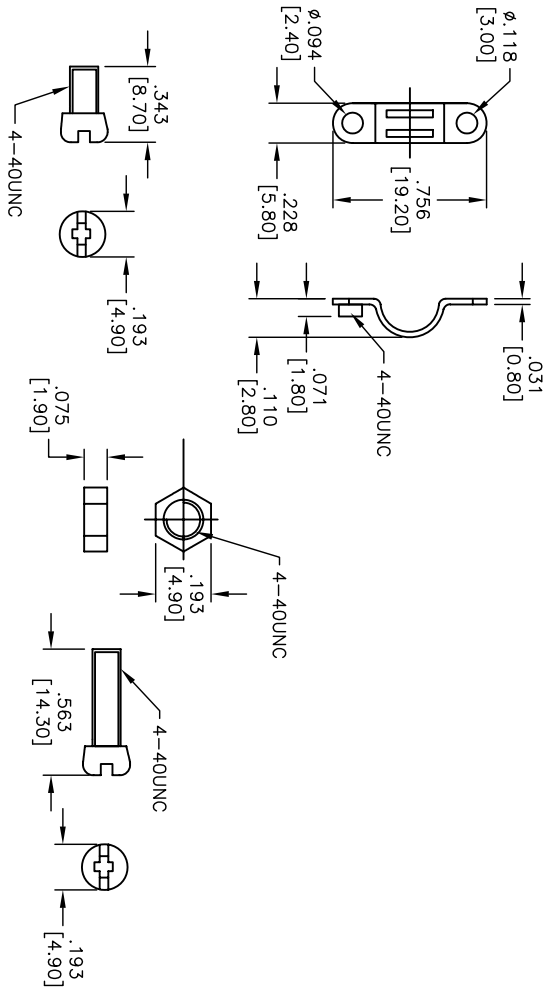
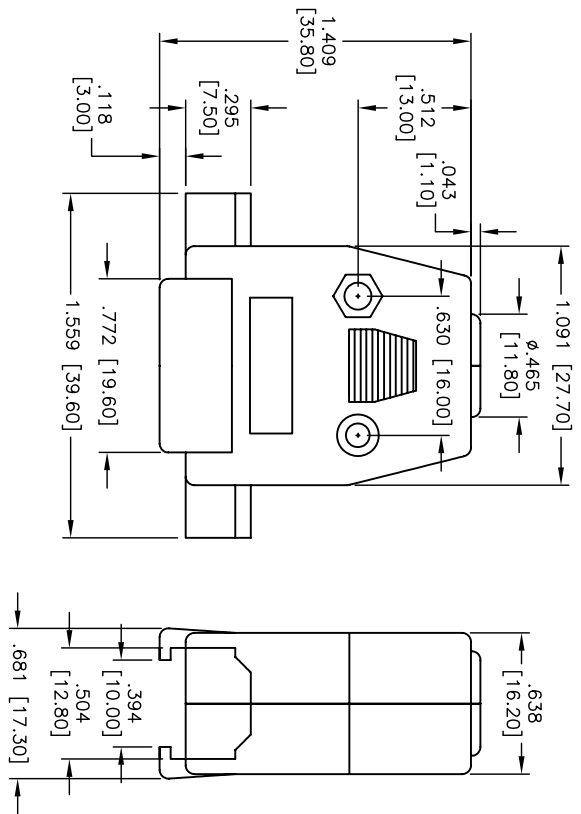
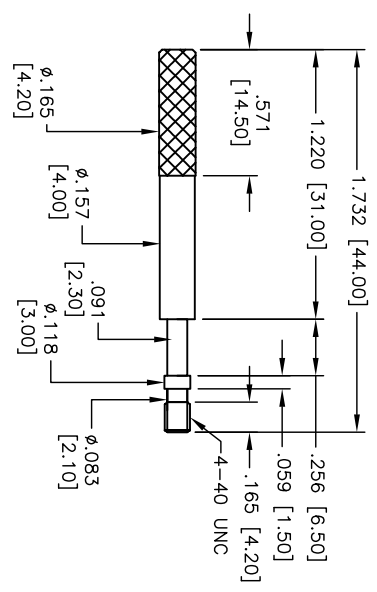
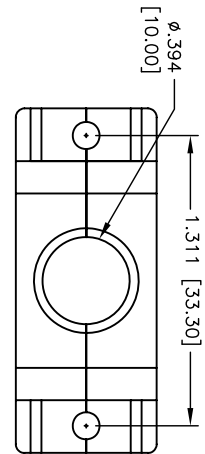

UNLESS OTHERWISE SPECIFIED
ALL DIMENSIONS ARE IN INCHES [MM]
TOLERANCES: EXCEPT AS NOTED
INCHES ± .10
Holes ± .10
X ± .020
.XX ± .015
XXX ± .015

ADAM TECH
909 Railway Avenue, Union, NJ 07083
Phone: 908-687-5000 Fax: 908-687-5710

D-SUB HOOD, THUMB SCREWS

APPROVALS	DATE	TITLE
DRAWN	HR	5/22/15
CHECKED	LL	5/22/15
APPROVED		
SIZE	PART NO.	REV.
X	DXXX-HD-PX-TS	-
REF:	SCALE: NTS	SHEET 2 OF 5

6

5

4

3

2

1

6

5

4

3

2

1

Rev	AWO #	Description	Date	Appr
		SEE SH1 1 OF 5 FOR REVISION		

APPROVED: _____

DATE: _____ TITLE: _____

DB25-HD-PX-TS

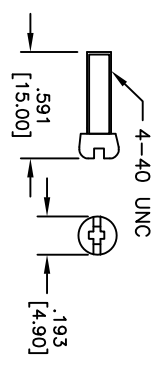
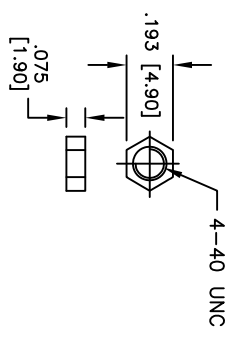
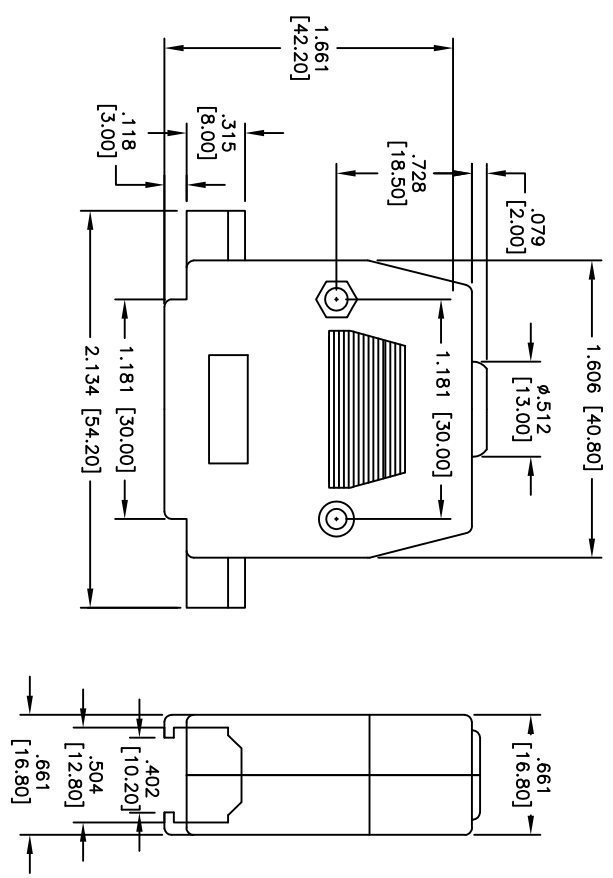
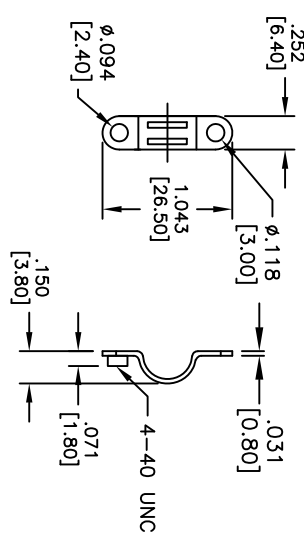
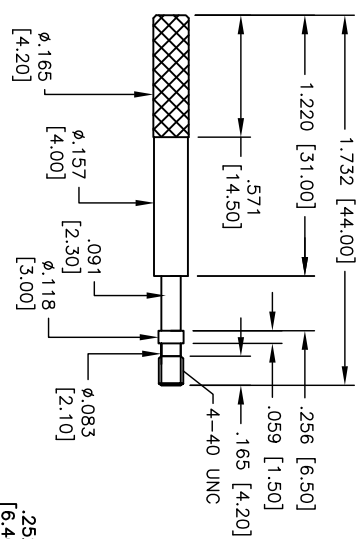
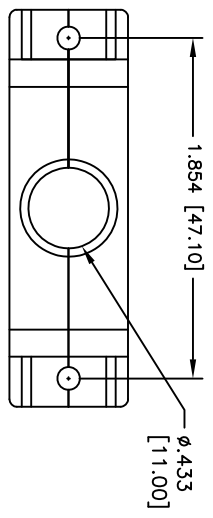

UNLESS OTHERWISE SPECIFIED
ALL DIMENSIONS ARE IN INCHES [MM]
TOLERANCES: EXCEPT AS NOTED
INCHES Holes ±.10
.XX ±.020
.XXX ±.015
APPROVALS DATE

ADAM TECH
909 Railway Avenue, Union, NJ 07083
Phone: 908-687-5000 Fax: 908-687-5710

D-SUB HOOD, THUMB SCREWS

DRAWN	HR	5/22/15	SIZE	PART NO.	REV.
CHECKED	LL	5/22/15	X	DXXX-HD-PX-TS	-
APPROVED			REF:	S000&T	SCALE: NTS SHEET 3 OF 5

6

5

4

3

2

1

6

5

4

3

2

1

Rev	AWO #	Description	Date	Appr
		SEE SH1 1 OF 5 FOR REVISION		

APPROVED: _____

DATE: _____ TITLE: _____

DC37-HD-PX-TS

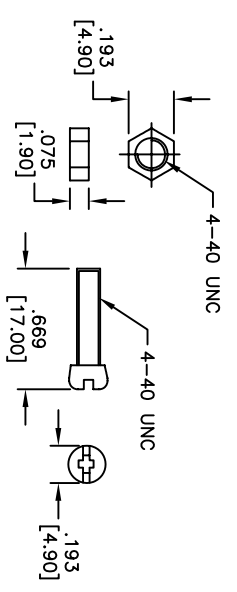
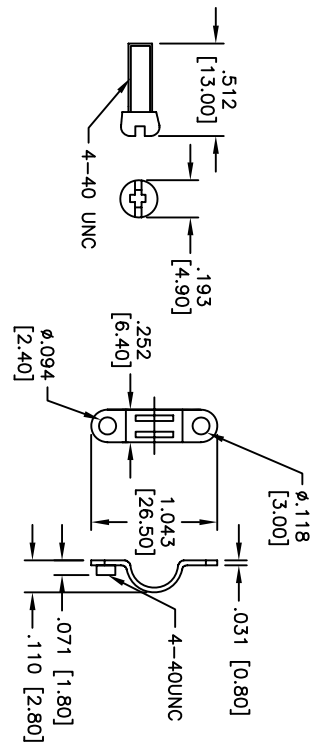
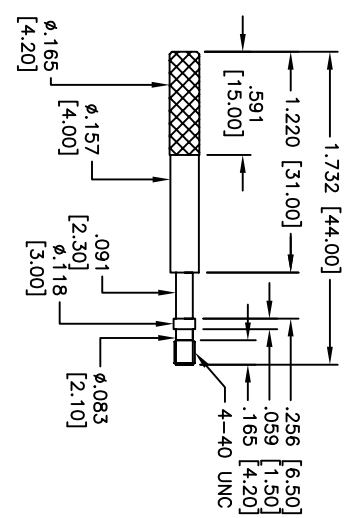
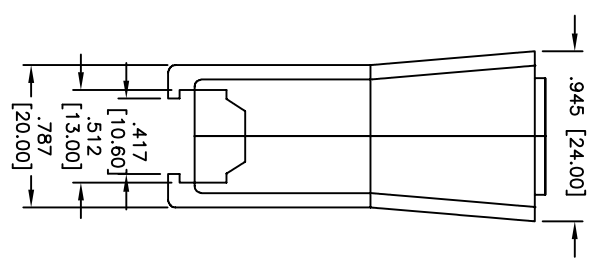
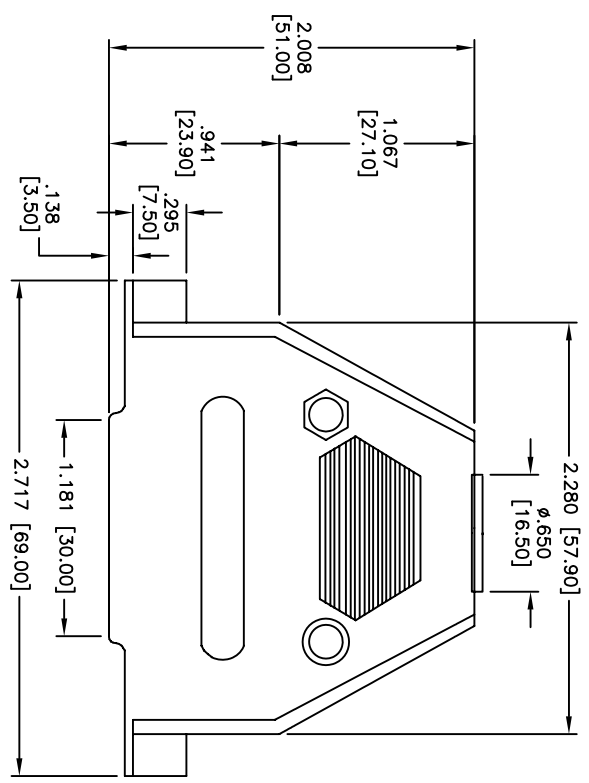
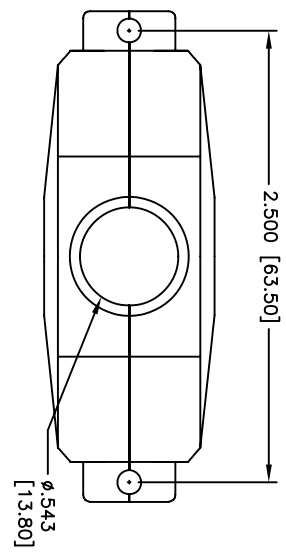

A

B

C

D

A

B

C

D

6

5

4

3

2

1

UNLESS OTHERWISE SPECIFIED
ALL DIMENSIONS ARE IN INCHES [MM]
TOLERANCES: EXCEPT AS NOTED

INCHES	
.X	± .10
.XX	± .020
.XXX	± .015
.XXX	± .010

APPROVALS	DATE
DRAWN AY	8/14/13
CHECKED AH	8/14/13
APPROVED	

ADAM TECH
909 Railway Avenue, Union, NJ 07083
Phone: 908-687-5000 Fax: 908-687-5710

TITLE		D-SUB HOOD, THUMB SCREWS	
SIZE	PART NO.	REV.	
X	DXXX-HD-PX-TS	-	
REF:	S00064T	SCALE:	NIS
		SHEET:	4 OF 5

