

THIS DRAWING IS UNPUBLISHED. RELEASED FOR PUBLICATION
 © COPYRIGHT - By - ALL RIGHTS RESERVED.

LOC		DIST		REVISIONS			
P	LTR	DESCRIPTION		DATE	DWN	APVD	
FT	47	G1	REVISED PER ECO-14-001124		24JAN2014	NK	MZ

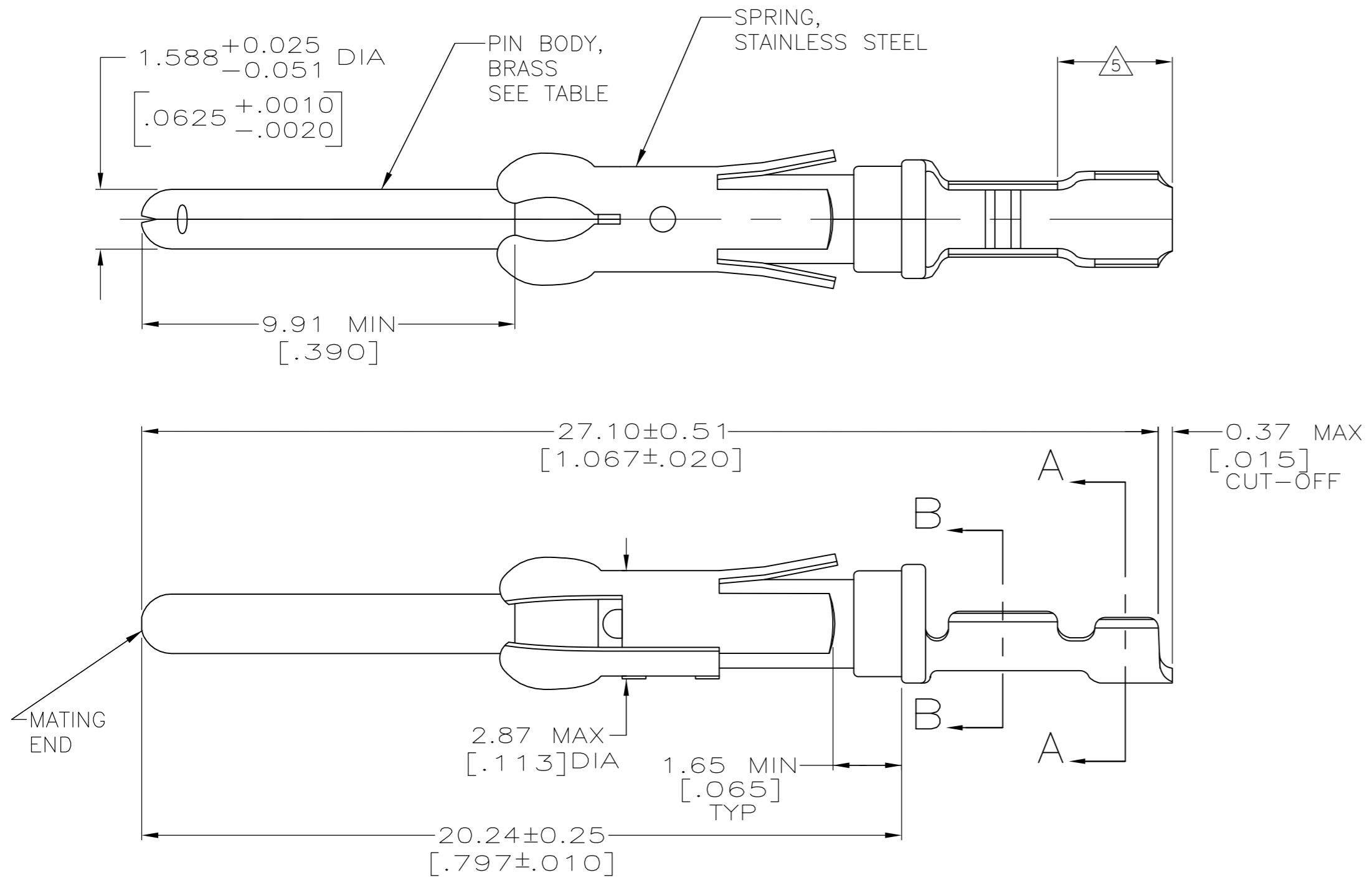

- 9 $0.38\mu\text{m}$ [.000015] MIN GOLD PER MIL-G-45204 ON MATING END FOR A LENGTH OF 5.08 [.200] MIN, $1.27\mu\text{m}$ [.000050] MIN TIN-LEAD PER MIL-T-10727 FOR A LENGTH OF 5.69 [.224] MIN ON OPPOSITE END, BOTH OVER $1.27\mu\text{m}$ [.000050] MIN NICKEL PER QQ-N-290 ON ENTIRE CONTACT.
- 10 $1.27\mu\text{m}$ [.000050] MIN TIN PER MIL-T-10727 OVER $1.27\mu\text{m}$ [.000050] MIN NICKEL PER QQ-N-290.

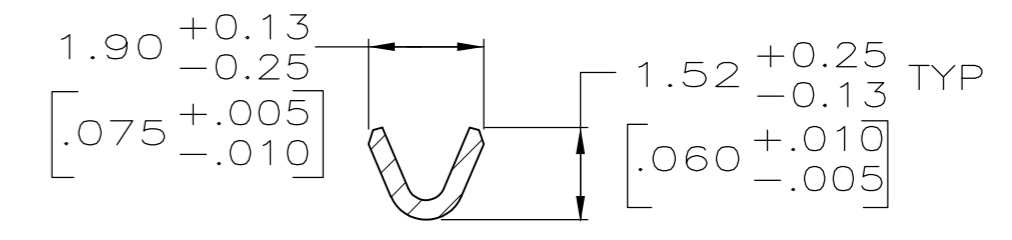
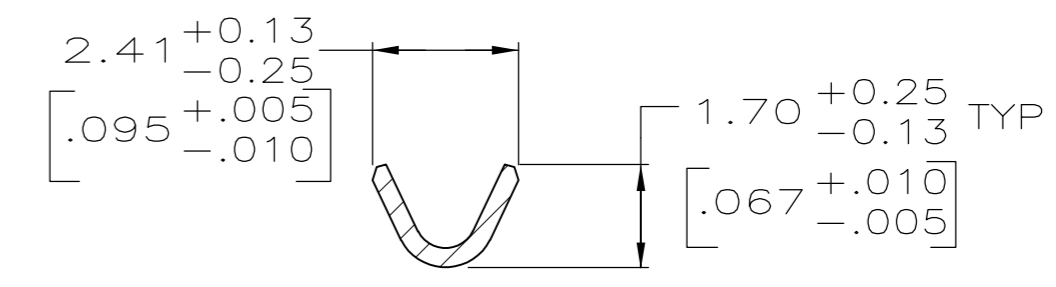

- 1 $0.76\mu\text{m}$ [.000030] MIN PRECIOUS METAL PLATE ON MATING END FOR A LENGTH OF 5.08 [.200] MIN WITH $1.27\mu\text{m}$ [.000050] MIN MATTE TIN PLATE IN WIRE CRIMP AREA, BOTH OVER $1.27\mu\text{m}$ [.000050] MIN NICKEL PLATE. CONFORMS TO THE REQUIREMENTS OF TE CONNECTIVITY PRODUCT SPEC 108-10042, BASED ON EIA/ECA-364-1000.01A (CONTROLLED ENVIRONMENT APPLICATIONS).
- 2 $0.76\mu\text{m}$ [.000030] MIN PRECIOUS METAL PLATE ON MATING END FOR A LENGTH OF 5.08 [.200] MIN WITH A UNIFORM GRADIENT TO $0.25\mu\text{m}$ [.000010] ON REMAINDER, OVER $1.27\mu\text{m}$ [.000050] MIN NICKEL PLATE. GOLD FLASH ALL OVER. CONFORMS TO THE REQUIREMENTS OF TE CONNECTIVITY PRODUCT SPEC 108-10042, BASED ON EIA/ECA-364-1000.01A (CONTROLLED ENVIRONMENT APPLICATIONS).
- 3 $0.38\mu\text{m}$ [.000015] MIN GOLD PER MIL-G-45204 ON MATING END FOR A LENGTH OF 5.08 [.200] MIN WITH $1.27\mu\text{m}$ [.000050] MIN MATTE TIN PLATE IN WIRE CRIMP AREA, BOTH OVER $1.27\mu\text{m}$ [.000050] MIN NICKEL PER QQ-N-290.
- 4 $1.27\mu\text{m}$ [.000050] MIN GOLD PER MIL-G-45204 ON MATING END FOR A LENGTH OF 5.08 [.200] MIN WITH GOLD FLASH ON THE REMAINDER OVER $1.90\mu\text{m}$ [.000075] MIN NICKEL PER QQ-N-290.
- 5 GOLD PLATING NOT REQUIRED IN THIS AREA.
- 6 $1.27\mu\text{m}$ [.000050] MIN TIN-LEAD PER MIL-T-10727 OVER $1.27\mu\text{m}$ [.000050] MIN NICKEL PER QQ-N-290.
- 7 WIRE RANGE 26-24 AWG.
- 8 INSULATION RANGE 0.89 [.035]- 1.40 [.055] DIA.

PACKAGING TYPE	PIN BODY FINISH	STRIP P/N REF	PART NO
SMALL PACK	10	1-66106-5 OR 1-66106-6	1-66107-2
STANDARD	10	1-66106-5 OR 1-66106-6	1-66107-1
SMALL PACK	1	66106-4	1-66107-0
SMALL PACK	6	66106-2	66107-9
OBSOLETE	STANDARD	1-66106-4	66107-8
OBSOLETE	STANDARD	1-66106-2	66107-7
STANDARD	1	66106-4	66107-4
STANDARD	3	66106-3	66107-3
STANDARD	6	66106-2	66107-2
STANDARD	2	66106-1	66107-1

THIS DRAWING IS A CONTROLLED DOCUMENT.

DWN	06/02/92	L.SIPE	
CHK	6-11-92	W.LENKER	
APVD	7-8-92	G.STEINHAUER	
PRODUCT SPEC		NAME	
APPLICATION SPEC		SIZE	
FINISH		CAGE CODE	
WEIGHT		DRAWING NO	
CUSTOMER DRAWING		RESTRICTED TO	

TE Connectivity

PIN ASSEMBLY, LOOSE PIECE, TYPE III+

SCALE 8:1 SHEET 1 OF 1 REV G1