

PRODUCT NUMBER NOTE 4	MATES WITH ASSY. SIZE	DIM "R"	DIM "S"	DIM "T"	DIM "Z" MAX
66563-001	2X20	2.18/55.37	2.06/52.32	2.01/51.05	2.18/55.52
66563-002	2X25	2.68/68.07	2.56/65.02	2.51/63.75	2.68/68.22
66563-003	2X5	0.68/17.27	0.56/14.22	0.51/12.95	0.68/17.42
66563-004	2X13	1.48/37.59	1.36/34.54	1.31/33.27	1.48/37.74
66563-005	2X17	1.88/47.75	1.76/44.70	1.71/43.43	1.88/47.90
66563-006	2X10	1.18/29.97	1.06/26.92	1.01/25.65	1.18/30.12
66563-007	2X7	0.88/22.35	0.76/19.30	0.71/18.03	0.88/22.50
66563-008	2X8	0.98/24.90	0.86/21.84	0.81/20.57	0.98/25.04
66563-009	2X30	3.18/80.77	3.06/77.72	3.01/76.45	3.18/80.92
66563-010	2X3	0.48/12.19	0.36/9.14	0.31/7.87	0.48/12.34
66563-011	2X4	0.58/14.73	0.46/11.68	0.41/10.41	0.58/14.88

DETAIL OF LATCH FEATURE

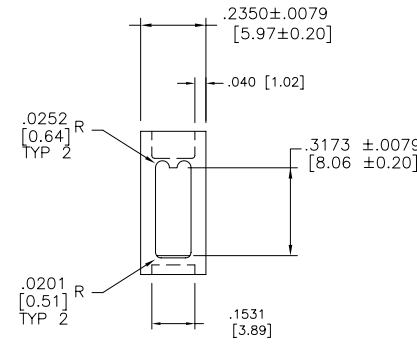
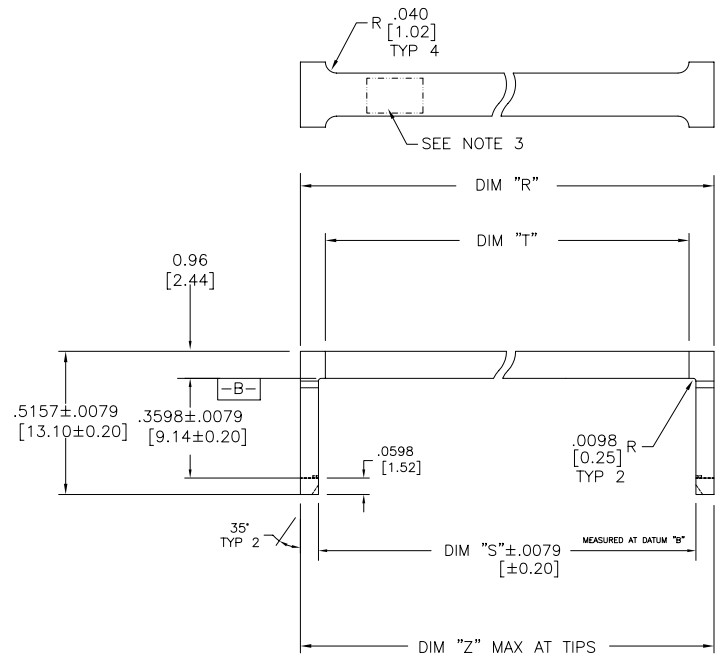
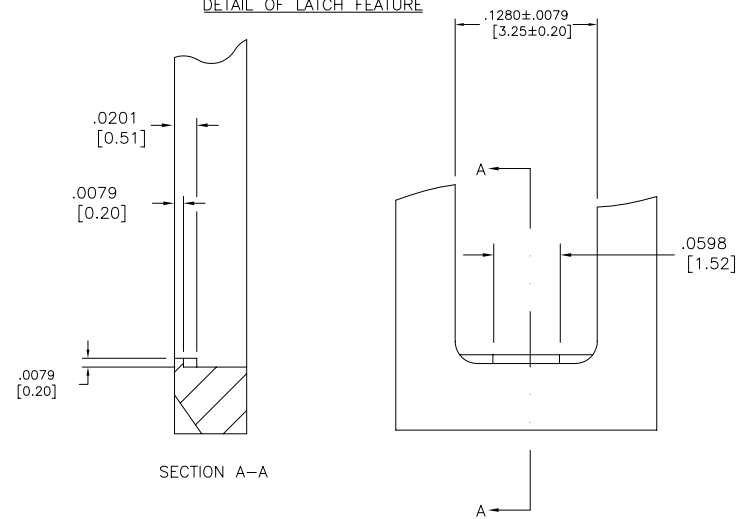

NOTES:

- UNREINFORCED THERMOPLASTIC POLYESTER FLAME-RETARDENT PER UL 94V-0, COLOR BLUE
- 0°/30° MAX DRAFT PERMITTED ON ALL SURFACES AS SHOWN.
- MOLDED COMPANY LOGO IN THIS AREA.
- ADD "LF" SUFFIX AT THE END OF PART NUMBER FOR LEAD FREE OPTION.
- THIS PRODUCT MEETS EUROPEAN UNION DIRECTIVES AND OTHER COUNTRY REGULATION AS DESCRIBED IN GS-22-008.
- THE PRODUCT IS NOT INTENDED TO BE EXPOSED TO A MANUFACTURING SOLDER PROCESS.

mat'l. code		surface ISO 1302 ✓		tolerance ISO 406 ISO 1101		projection INCH/MM		product family QUICKIE	
ltr	ecn no	dr	date	tolerances unless otherwise specified				title	
A	5003	WFO	4/01/83	angles	.XX±.01/.3	INCH/MM		SPECIAL LOW PROFILE STRAIN-RELIEF	
B	M06-0475	MHT	12/05/06	linear	.XXX±.005/.13	scale 5:1		dwg no sheet 1 of 1 size	
				0°±2'	.XXXX±.0020/.051	FCJ		66563 A3	
		dr	WFO	4/01/83				type Product Customer Drawing	
		enr	WFO	4/01/83					
		chr	WFO	4/01/83					
		appd	WFO	4/01/83					
sheet index	revision sheet	B	1						



Copyright FCI