

REVISIONS				
P	LTR	DESCRIPTION	DATE	APVD
	D4	REVISED PER ECN-22-156403	03JUN2022	RK CSD

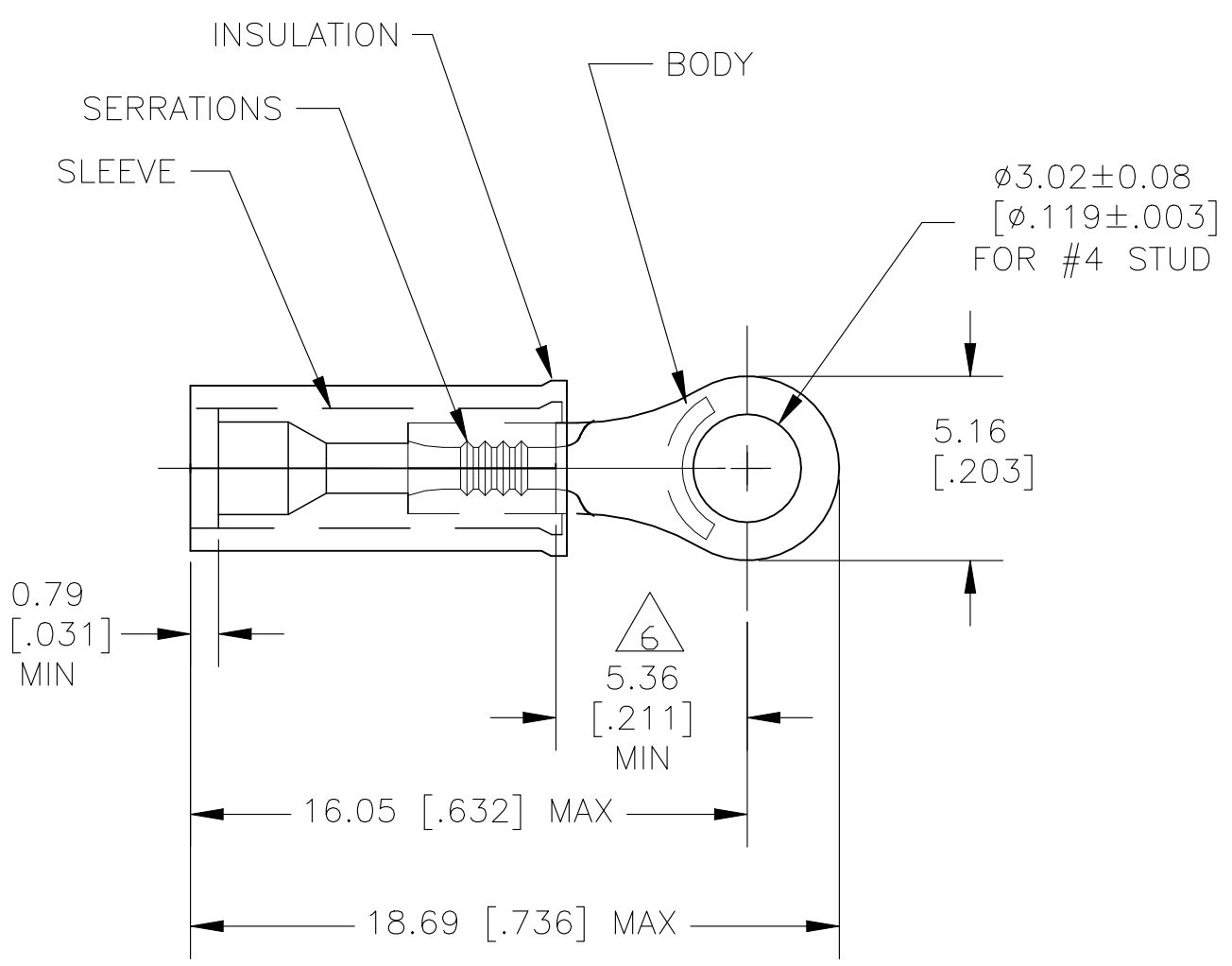

- 1 MUST BE CRIMPED WITH A 22-18 OR 22-16 P.I.D.G. (RED) TOOL.
- 2 WIRE INSULATION DIA: 1.3-2.7 [.050-.105]
- 3 TONGUE MATERIAL THK: 0.68±0.051 [.027±.002]
- △4 BODY & SLEEVE: TIN PLATE PER ASTM B545.
- △5 MATERIAL: BODY & SLEEVE- CU PER ASTM B152 INSULATION - NYLON, COLOR - YELLOW
- △6 APPLIES FROM EDGE OF METAL WIRE BARREL TO CENTER OF STUD HOLE.
- △7 REELING REQUIRES INTERLEAVING
- △8 MEETS MS25036-144, CLASS 1
- △9 PRELIMINARY - NOT FOR PRODUCTION

△7	2500	TAPE & REEL	△9	2-52189-1
	1000	LOOSE PIECE	△8	52189
	QTY	PACKAGE TYPE		PART NO.

AMP INCORPORATED CUSTOMER SERVICE SYSTEMS		MAX RECOMMENDED OPERATING TEMPERATURE: 105°C MAX	THIS DRAWING IS A CONTROLLED DOCUMENT.		DWN JR RUTH 07FEB08	TE Connectivity NAME TERMINAL, RECTANGULAR TONGUE, PIDG WIRE SIZE: 26-24 AWG							
FOR ADDITIONAL PRODUCT INFORMATION OR COPIES OF DRAWINGS AND TECHNICAL DOCUMENTS	PRODUCT INFORMATION CENTER 1-800-522-6752	VOLTAGE RATING: N/A	DIMENSIONS: MM [INCHES]	TOLERANCES UNLESS OTHERWISE SPECIFIED:	CHK T MICHELUTTI 29MAY07					APVD T MICHELUTTI 29MAY07	PRODUCT SPEC	APPLICATION SPEC	RESTRICTED TO
FOR APPLICATION TOOLING INFORMATION	TOOLING ASSISTANCE CENTER 1-800-722-1111	CIRCULAR MIL AREA: 0.10-0.26mm² [202-509] STRANDED		0 PLC ± - 1 PLC ± - 2 PLC ± 0.20[.008] 3 PLC ± - 4 PLC ± - ANGLES ± -	FINISH	△4	△5	SIZE A3	CAGE CODE 00779	DRAWING NO C-52189	SCALE 4:1	SHEET 1 OF 1	REV D4
FOR ORDER ENTRY	1-800-526-5142	THIS DRAWING IS A CONTROLLED DOCUMENT FOR AMP INCORPORATED. IT IS SUBJECT TO CHANGE AND THE CONTROLLING ENGINEERING ORGANIZATION SHOULD BE CONTACTED FOR THE LATEST REVISION.		MATERIAL	CUSTOMER DRAWING		SCALE 4:1		SHEET 1 OF 1		REV D4		