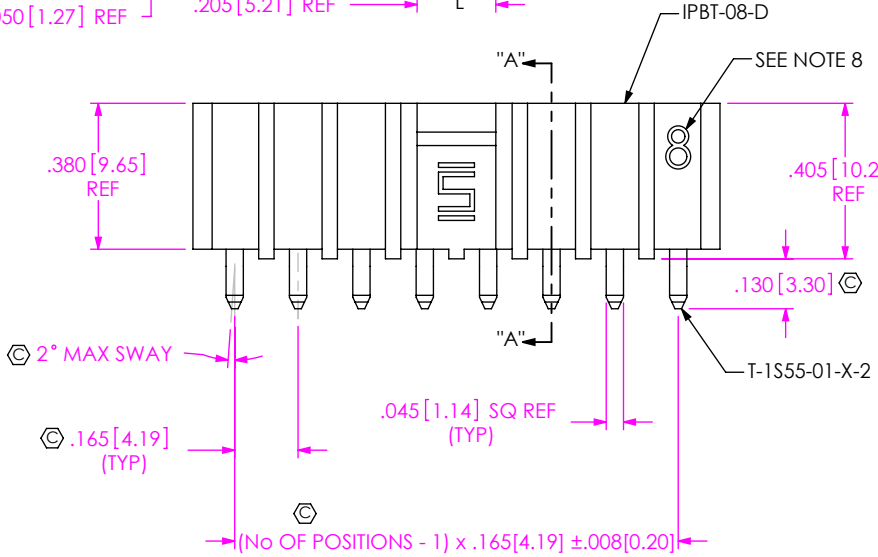
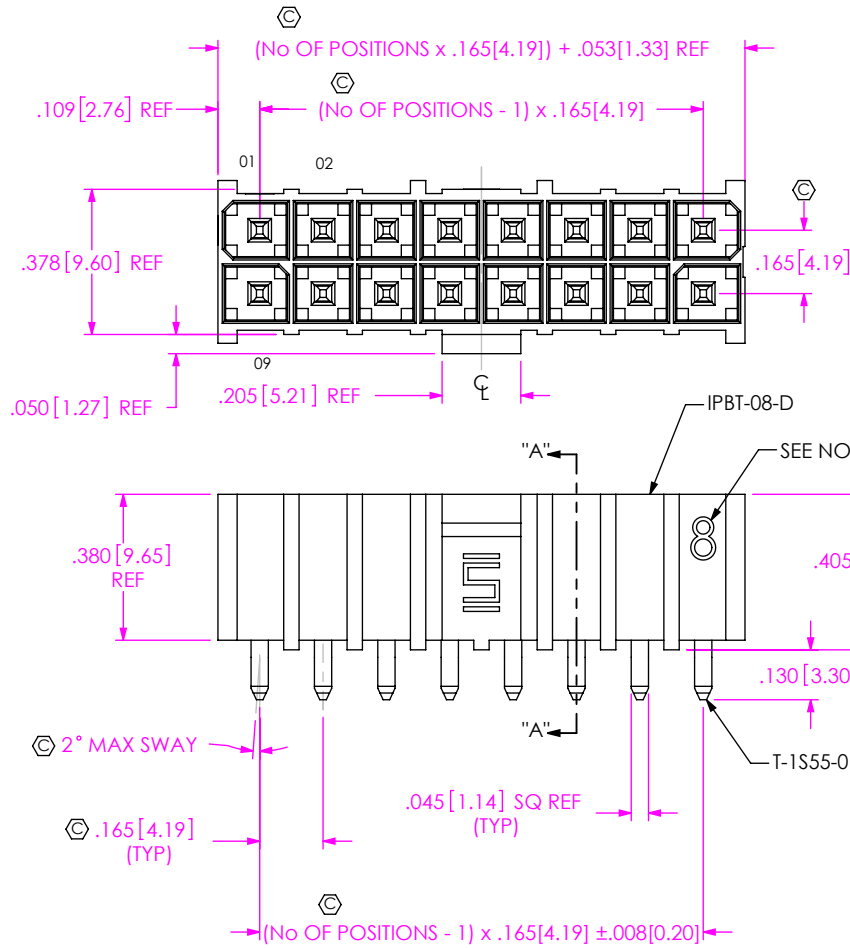

FIG. 1
(IPBT-108-H1-XX-D SHOWN)

DO NOT SCALE FROM THIS PRINT



No OF POSITIONS
-02 THRU -15
(PER ROW)
-02 (SEE SHEET 5, FIG.8)

LEAD STYLE
-H1: HIGH POWER, THRU HOLE
(USE T-1S55-XX-X-2, SEE FIG 1, SHEET 1)
-H2: HIGH POWER, SURFACE MOUNT
(USE T-1S55-02-X-2, SEE FIG 3, SHEET 3)
-H3: HIGH POWER, THRU HOLE, .670" STACKER
(USE T-1S55-05-X-2, SEE FIG 5, SHEET 4)
-H4: HIGH POWER, THRU HOLE, .748" STACKER
(USE T-1S55-06-X-2, SEE FIG 5, SHEET 4)
-H5: HIGH POWER, THRU HOLE, .787" STACKER
(USE T-1S55-07-X-2, SEE FIG 5, SHEET 4)
-H6: HIGH POWER, THRU HOLE, .984" STACKER
(USE T-1S55-08-X-2, SEE FIG 6, SHEET 4)

OPTION
-RA: RIGHT ANGLE (SEE FIG 2, SHEET 2)
[STYLE -H1 ONLY]
-GP: GUIDE POSTS (USE IPBT-XX-D-GP,
SEE FIG 4, SHEET 3)
(NOT AVAILABLE W/ -K OPTION)
* -K: KEYED POLARIZATION
(USE IPBT-XX-D-K) (SEE FIG 9, SHEET 5)
(NOT AVAILABLE W/ -GP OPTION)

ROW SPECIFICATION
-D: DOUBLE (USE IPBT-XX-D)

PLATING SPECIFICATION
-T: MATTE TIN CONTACT AND TAIL
(USE T-1S55-XX-T-2)
-TM: MATTE TIN CONTACT AND TAIL
(USE T-1S55-XX-T-2)
-L: 10µ" GOLD ON CONTACT, TIN ON TAIL
(USE T-1S55-XX-L-2)
-S: 30µ" GOLD ON CONTACT, TIN ON TAIL
(USE T-1S55-XX-S-2)

(* = LEAVE BLANK FOR NO KEY OPTION,
SAMTEC WILL ONLY SUPPORT EXISTING
BUSINESS AS OF REV W)

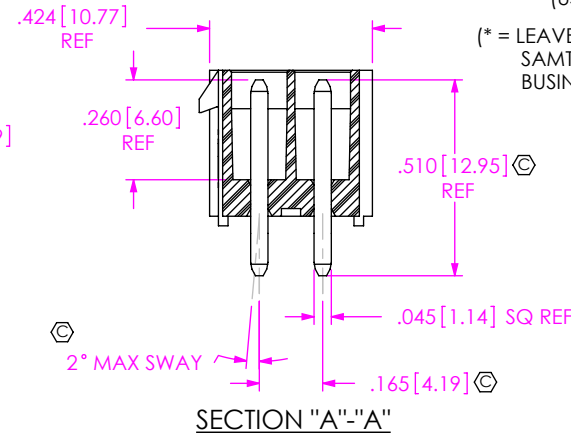
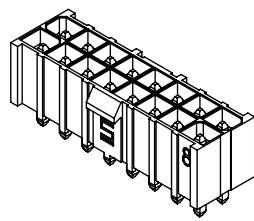

TABLE 1

LEAD	BODY 1	BODY 2	TERMINAL 1	OAL REF	TERMINAL 2
-H1	IPBT-XX-D	N/A	T-1S55-01-X-2	.5100 [12.954]	N/A
-H2	IPBT-XX-D	N/A	T-1S55-02-X-2	.5100 [12.954]	N/A
-H1-RA	IPBT-XX-D	N/A	T-1S55-03-X-2	.5100 [12.954]	T-1S55-04-X-2
-H1-RA-GP	IPBT-XX-D-GP	N/A	T-1S55-03-X-2	.5100 [12.954]	T-1S55-04-X-2
-H1-GP	IPBT-XX-D-GP	N/A	T-1S55-01-X-2	.5100 [12.954]	N/A
-H3-GP	IPBT-XX-D-GP	IPBV-XX-D	T-1S55-05-X-2	.5100 [12.954]	N/A
-H4-GP	IPBT-XX-D-GP	CUT FROM IPBE-31-H4-D	T-1S55-06-X-2	.5100 [12.954]	N/A
-H5-GP	IPBT-XX-D-GP	CUT FROM IPBE-31-H5-D	T-1S55-07-X-2	.5100 [12.954]	N/A
-H6-GP	IPBT-XX-D-GP	CUT FROM IPBE-31-H6-D	T-1S55-08-X-2	.5100 [12.954]	N/A
-H3	IPBT-XX-D	IPBV-XX-D	T-1S55-05-X-2	.5100 [12.954]	N/A
-H4	IPBT-XX-D	CUT FROM IPBE-31-H4-D	T-1S55-06-X-2	.5100 [12.954]	N/A
-H5	IPBT-XX-D	CUT FROM IPBE-31-H5-D	T-1S55-07-X-2	.5100 [12.954]	N/A
-H6	IPBT-XX-D	CUT FROM IPBE-31-H6-D	T-1S55-08-X-2	.5100 [12.954]	N/A

- NOTES:
1. Ⓢ REPRESENTS A CRITICAL DIMENSION.
 2. COPLANARITY (FOR SURFACE MOUNT): SEE TABLE 2 SHEET 3.
 3. MAX BURR ALLOWANCE: .0015 [0.038].
 4. MINIMUM TERMINAL RETENTION: 1 LB.
 5. IPBT-XX-D-XX AND IPBV-XX-D PARTS TO BE MOLDED TO POSITION, IPBE-XX-XX-D ARE TO BE CUT.
 6. MAX HEIGHT VARIATION BETWEEN PINS: .005 [0.13].
 7. ALL PIN TO PIN DIMENSIONS TO BE MEASURED FROM TIP TO TIP.
 8. THIS NUMBER REPRESENTS THE NUMBER OF POSITIONS PER ROW ONLY AND IS NOT INTENDED TO BE USED IN POSITION NUMBERING.
 9. ALL PARTS TO BE PACKAGED IN TUBES EXCEPT 2 AND 3 POS. 2 AND 3 POS PARTS TO BE LAYER PACKAGED.
 10. MAX CUT FLASH: .005 [0.13].
 11. AFTER REVISION T OF COMPONENT PRINT IPT1-XX-D-XX-X, SAMTEC LOGO TO APPEAR ON CORE #1 FOR POSITIONS 1 THROUGH 5. FOR POSITIONS 6 THROUGH 15, LOGO TO APPEAR ON CORE #1 AND THE LAST CORE WITHIN THE SAME ROW.
 12. ORDERS WILL BE PACKAGED ACCORDING TO THE SAMTEC PACKAGING EFFICIENCY STANDARDS (SPES) FOUND ON WWW.SAMTEC.COM.



UNLESS OTHERWISE SPECIFIED, DIMENSIONS ARE IN INCHES. TOLERANCES ARE:
DECIMALS .XX: ±.01 [0.3]
.XXX: ±.005 [0.13]
.XXXX: ±.0020 [0.051]

PROPRIETARY NOTE
THIS DOCUMENT CONTAINS CONFIDENTIAL AND PROPRIETARY INFORMATION AND ALL DESIGN, MANUFACTURING, REPRODUCTION, USE, PATENT RIGHTS AND SALES RIGHTS ARE EXPRESSLY RESERVED BY SAMTEC, INC. THIS DOCUMENT SHALL NOT BE DISCLOSED, IN WHOLE OR PART, TO ANY UNAUTHORIZED PERSON OR ENTITY NOR REPRODUCED, TRANSFERRED OR INCORPORATED IN ANY OTHER PROJECT IN ANY MANNER WITHOUT THE EXPRESS WRITTEN CONSENT OF SAMTEC, INC.



520 PARK EAST BLVD. NEW ALBANY, IN 47150
PHONE: 812-944-6733 FAX: 812-948-5047
e-Mail info@SAMTEC.com code 55322

MATERIAL: DO NOT SCALE DRAWING SHEET SCALE: 2:1
INSULATOR: LCP UL 94 VO, COLOR: BLACK
TERMINAL: HIGH COPPER ALLOY

DESCRIPTION: .165 DOUBLE ROW TERMINAL ASSEMBLY
DWG. NO. IPBT-1XX-XX-XX-D-XX

BY: DEAN P 7/27/2001 SHEET 1 OF 5

-RA: RIGHT ANGLE IN-PROCESS VIEWS

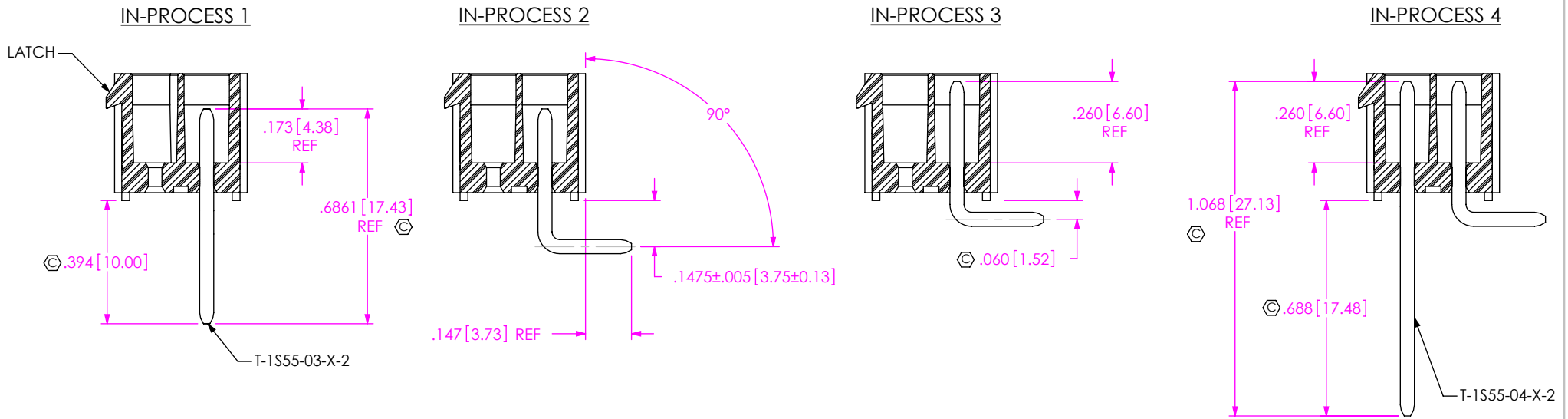
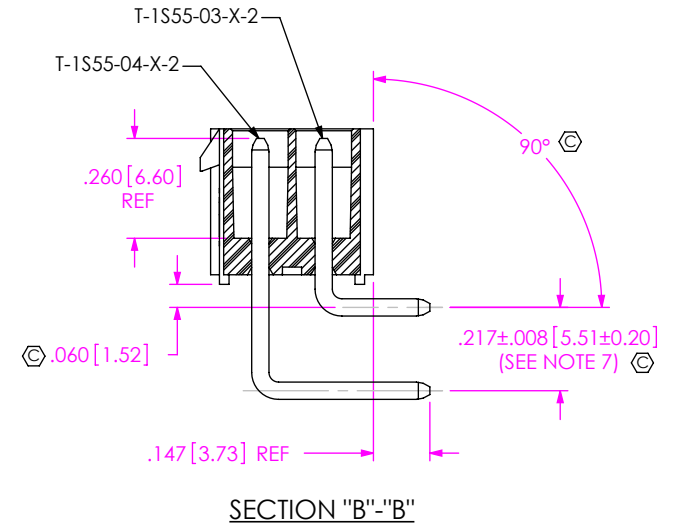
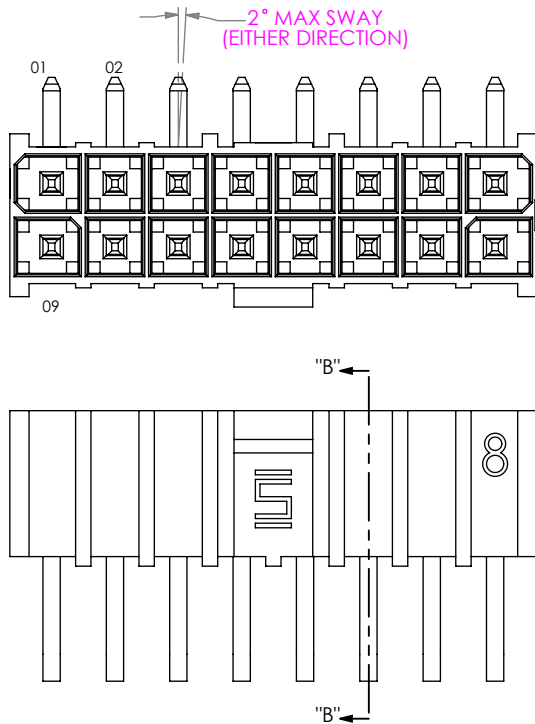

FIG 2
 (IPBT-108-H1-XX-D-RA SHOWN)
 (DIFFERENT AS SHOWN, OTHERWISE SAME AS FIG 1)
 (AVAILABLE ONLY ON -H1)



PROPRIETARY NOTE
 THIS DOCUMENT CONTAINS CONFIDENTIAL AND PROPRIETARY INFORMATION AND ALL DESIGN, MANUFACTURING, REPRODUCTION, USE, PATENT RIGHTS AND SALES RIGHTS ARE EXPRESSLY RESERVED BY SAMTEC, INC. THIS DOCUMENT SHALL NOT BE DISCLOSED, IN WHOLE OR PART, TO ANY UNAUTHORIZED PERSON OR ENTITY NOR REPRODUCED, TRANSFERRED OR INCORPORATED IN ANY OTHER PROJECT IN ANY MANNER WITHOUT THE EXPRESS WRITTEN CONSENT OF SAMTEC, INC.

DO NOT SCALE DRAWING

SHEET SCALE: 2:1



520 PARK EAST BLVD, NEW ALBANY, IN 47150
 PHONE: 812-944-6733 FAX: 812-948-5047
 e-Mail: info@SAMTEC.com code 55322

DESCRIPTION:
 .165 DOUBLE ROW TERMINAL ASSEMBLY

DWG. NO.
IPBT-1XX-XX-XX-D-XX

BY: DEAN P 7/27/2001 SHEET 2 OF 5

FIG 3
(IPBT-108-H2-XX-D SHOWN)
(DIFFERENT AS SHOWN, OTHERWISE SAME AS FIG 1

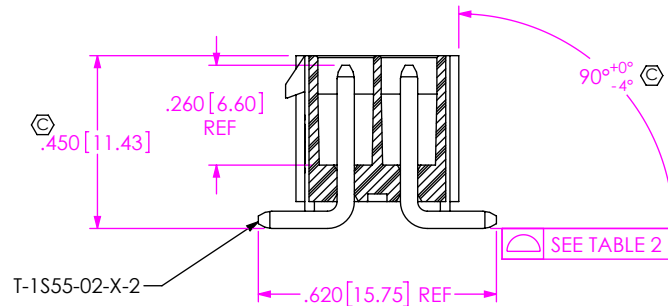
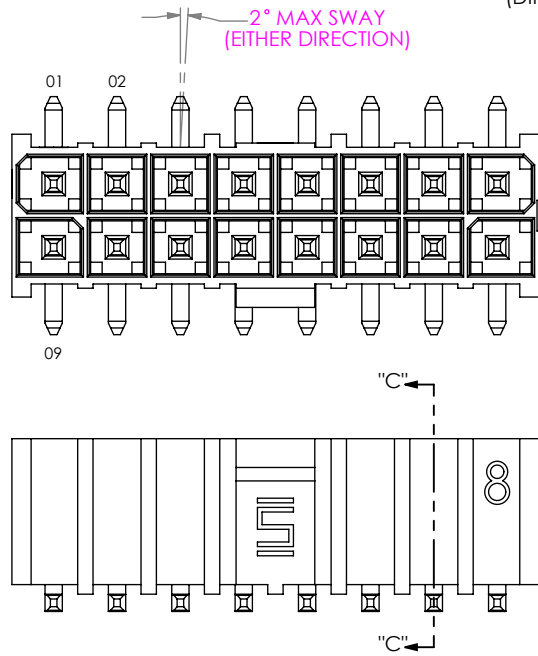

SECTION "C"-"C"

TABLE 2	
No OF POSITIONS	COPLANARITY
-02 THRU -08	.004[.10]
-09 THRU -15	.006[.15]

H2: SURFACE MOUNT IN-PROCESS VIEWS

IN-PROCESS 1

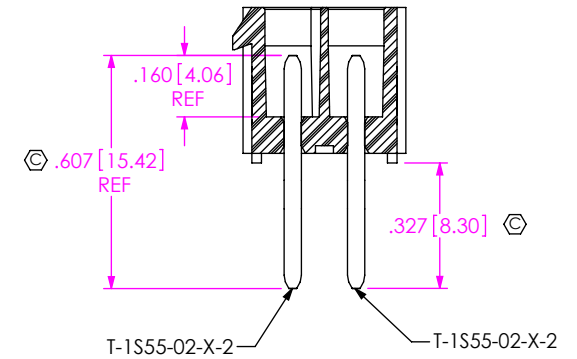

IN-PROCESS 2

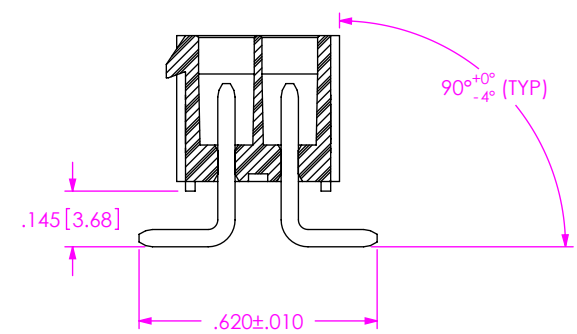
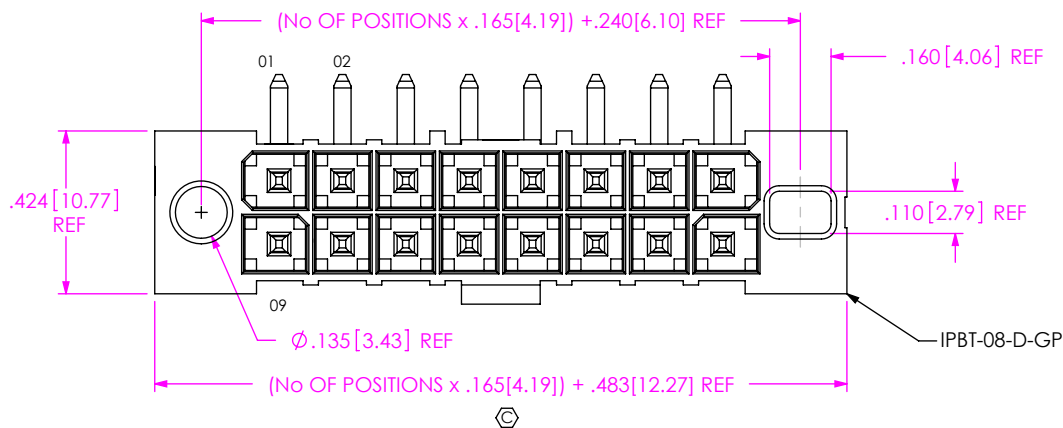

FIG 4
(IPBT-108-H1-XX-D-RA-GP SHOWN)
(DIFFERENT AS SHOWN, OTHERWISE SAME AS FIG 1, 2 OR 3)



PROPRIETARY NOTE

THIS DOCUMENT CONTAINS CONFIDENTIAL AND PROPRIETARY INFORMATION AND ALL DESIGN, MANUFACTURING, REPRODUCTION, USE, PATENT RIGHTS AND SALES RIGHTS ARE EXPRESSLY RESERVED BY SAMTEC, INC. THIS DOCUMENT SHALL NOT BE DISCLOSED, IN WHOLE OR PART, TO ANY UNAUTHORIZED PERSON OR ENTITY NOR REPRODUCED, TRANSFERRED OR INCORPORATED IN ANY OTHER PROJECT IN ANY MANNER WITHOUT THE EXPRESS WRITTEN CONSENT OF SAMTEC, INC.

DO NOT SCALE DRAWING

SHEET SCALE: 1:0.470588



520 PARK EAST BLVD, NEW ALBANY, IN 47150
PHONE: 812-944-6733 FAX: 812-948-5047
e-Mail info@SAMTEC.com code 55322

DESCRIPTION: .165 DOUBLE ROW TERMINAL ASSEMBLY

DWG. NO. IPBT-1XX-XX-XX-D-XX

BY: DEAN P 7/27/2001 SHEET 3 OF 5

TABLE 4		
LEADSTYLE	"C"	"D"
-H3	.579 [14.71]	.094 [2.40]
-H4	.658 [16.71]	.173 [4.39]
-H5	.697 [17.70]	.212 [5.38]
-H6	.894 [22.71]	.409 [10.39]

IN PROCESS 1
(FOR H4, H5, & H6 ONLY)

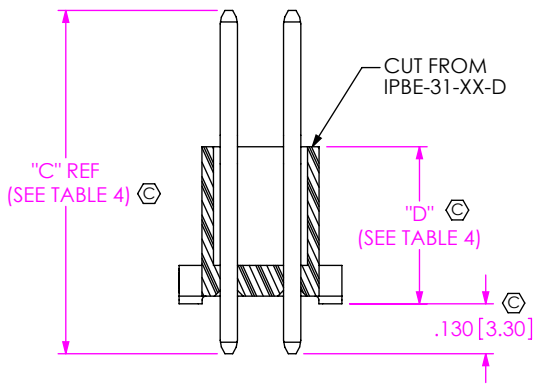

IN PROCESS 1
(FOR H3 ONLY)

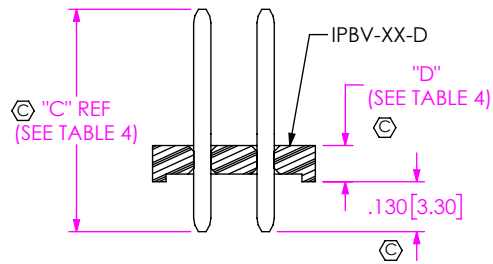

FIG 5
(IPBT-108-H3-XX-D SHOWN)
(DIFFERENT AS SHOWN, OTHERWISE SAME AS FIG. 1)

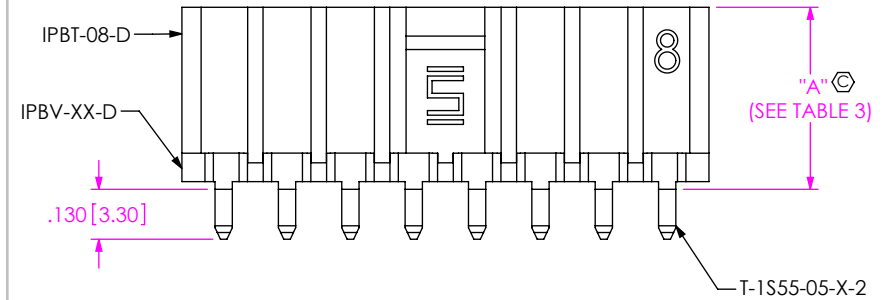

TABLE 3		
LEADSTYLE	"A"	STACK HEIGHT WITH IPBS-TH
-H3	.474 [12.05]	.669 [16.99]
-H4	.553 [14.05]	.748 [19.00]
-H5	.592 [15.04]	.787 [19.99]
-H6	.789 [20.04]	.984 [24.99]

FIG 6
(IPBT-108-H6-XX-D SHOWN)
(DIFFERENT AS SHOWN, OTHERWISE SAME AS FIG. 1)

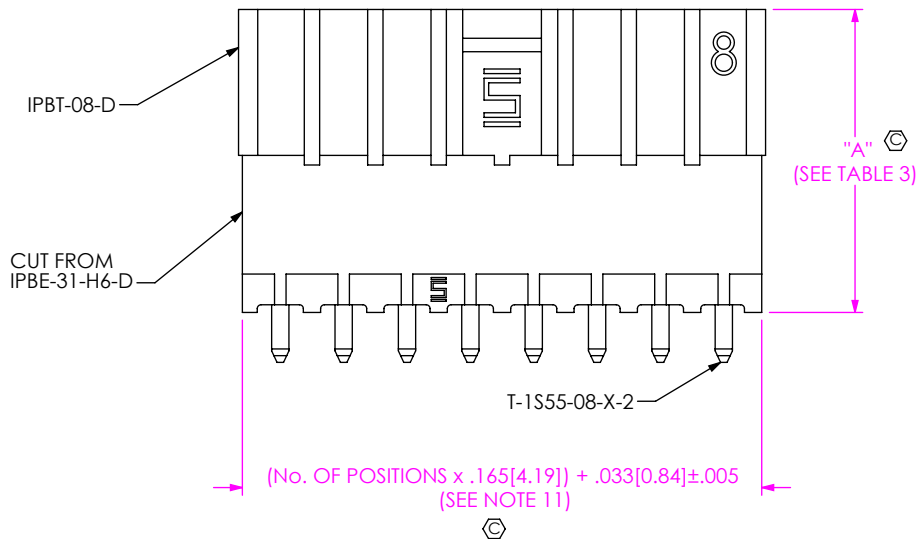
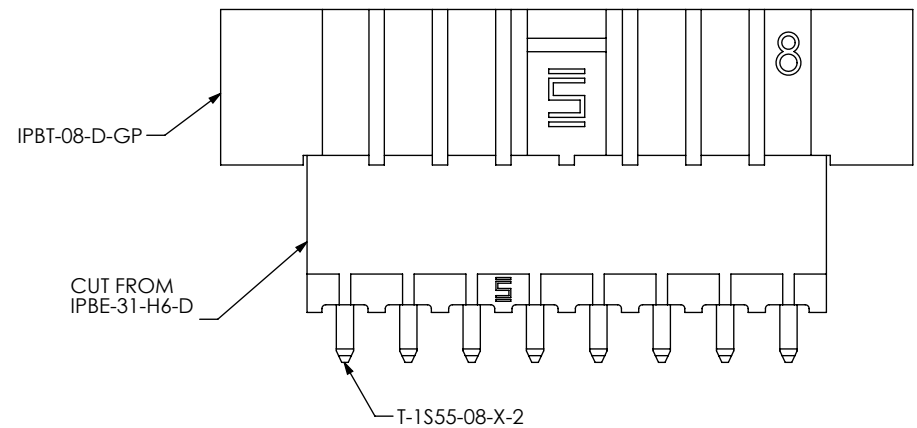

FIG 7
(IPBT-108-H6-XX-D-GP SHOWN)
(DIFFERENT AS SHOWN, OTHERWISE SAME AS FIG. 1, 5, OR 6)



PROPRIETARY NOTE

THIS DOCUMENT CONTAINS CONFIDENTIAL AND PROPRIETARY INFORMATION AND ALL DESIGN, MANUFACTURING, REPRODUCTION, USE, PATENT RIGHTS AND SALES RIGHTS ARE EXPRESSLY RESERVED BY SAMTEC, INC. THIS DOCUMENT SHALL NOT BE DISCLOSED, IN WHOLE OR PART, TO ANY UNAUTHORIZED PERSON OR ENTITY NOR REPRODUCED, TRANSFERRED OR INCORPORATED IN ANY OTHER PROJECT IN ANY MANNER WITHOUT THE EXPRESS WRITTEN CONSENT OF SAMTEC, INC.

DO NOT SCALE DRAWING

SHEET SCALE: 2:1

samtec

520 PARK EAST BLVD, NEW ALBANY, IN 47150
PHONE: 812-944-6733 FAX: 812-948-5047
e-Mail info@SAMTEC.com code 55322

DESCRIPTION:
.165 DOUBLE ROW TERMINAL ASSEMBLY

DWG. NO.
IPBT-1XX-XX-XX-D-XX

BY: DEAN P 7/27/2001 SHEET 4 OF 5

FIG 8
(IPBT-102-H1-XX-D SHOWN)
(DIFFERENT AS SHOWN,
OTHERWISE SAME AS FIG 1)

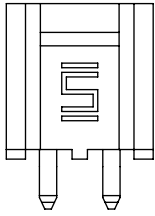
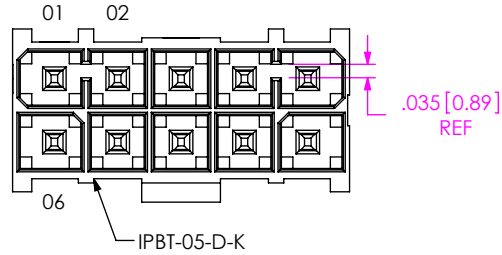
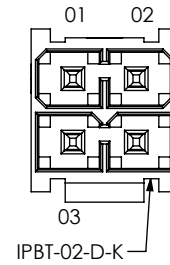

FIG 9
(IPBT-1XX-H1-XX-D-K SHOWN)
(DIFFERENT AS SHOWN, OTHERWISE SAME AS FIG 1)

-105 POS SHOWN
(TYPICAL FOR POSITIONS 3 THRU 15)



-102 POS SHOWN
(DIFFERENT AS SHOWN)



PACKAGING VIEWS
[PARTS TO HAVE POSITION #1 LOADED IN
SAME DIRECTION AS ARROW ON TUBE]
(SEE NOTE 9)

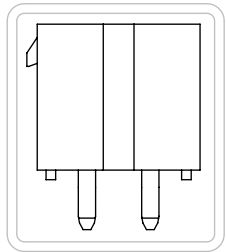

IPBT-1XX-H1-XX-D-XX SHOWN
TUBE: PT-1-24-01-112
PLUG: TP-28

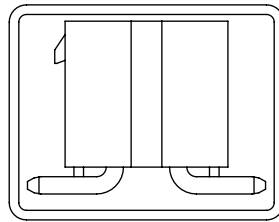

IPBT-1XX-H2-XX-D-XX SHOWN
TUBE: PT-1-24-02-112
PLUG: TP-28

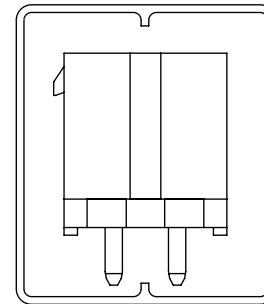

IPBT-1XX-H3-XX-D-XX SHOWN
TUBE: PT-1-24-04-56
PLUG: TP-25

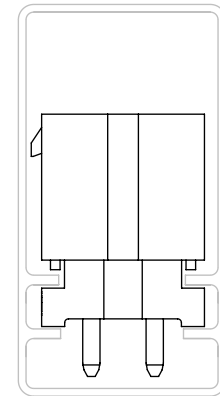

IPBT-1XX-H4-XX-D-XX SHOWN
TUBE: PT-IPBT001-H4-H6
PLUG: TP-28

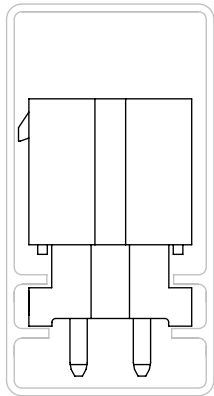

IPBT-1XX-H5-XX-D-XX SHOWN
TUBE: PT-IPBT001-H4-H6
PLUG: TP-28

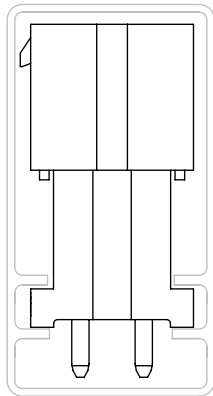

IPBT-1XX-H6-XX-D-XX SHOWN
TUBE: PT-IPBT001-H4-H6
PLUG: TP-28

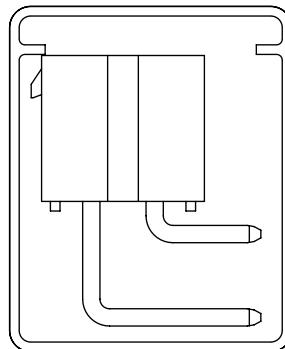

IPBT-1XX-H1-XX-D-RA SHOWN
TUBE: PT-1-24-19T-109
PLUG: TP-25 (2 EACH END)

PROPRIETARY NOTE
THIS DOCUMENT CONTAINS CONFIDENTIAL AND PROPRIETARY INFORMATION AND ALL DESIGN, MANUFACTURING, REPRODUCTION, USE, PATENT RIGHTS AND SALES RIGHTS ARE EXPRESSLY RESERVED BY SAMTEC, INC. THIS DOCUMENT SHALL NOT BE DISCLOSED, IN WHOLE OR PART, TO ANY UNAUTHORIZED PERSON OR ENTITY NOR REPRODUCED, TRANSFERRED OR INCORPORATED IN ANY OTHER PROJECT IN ANY MANNER WITHOUT THE EXPRESS WRITTEN CONSENT OF SAMTEC, INC.

DO NOT SCALE DRAWING

SHEET SCALE: 2:1



520 PARK EAST BLVD, NEW ALBANY, IN 47150
PHONE: 812-944-6733 FAX: 812-948-5047
e-Mail info@SAMTEC.com code 55322

DESCRIPTION:
.165 DOUBLE ROW TERMINAL ASSEMBLY

DWG. NO. **IPBT-1XX-XX-XX-D-XX**

BY: DEAN P 7/27/2001 SHEET 5 OF 5