



H11AA1, H11AA3, H11AA2, H11AA4 AC Input/Phototransistor Optocouplers

Features

- Bi-polar emitter input
- Built-in reverse polarity input protection
- Underwriters Laboratory (UL) recognized – File #E90700
- VDE approved – File #E94766 (ordering option '300')

Description

The H11AAX series consists of two gallium-arsenide infrared emitting diodes connected in inverse parallel driving a single silicon phototransistor output.

Applications

- AC line monitor
- Unknown polarity DC sensor
- Telephone line interface

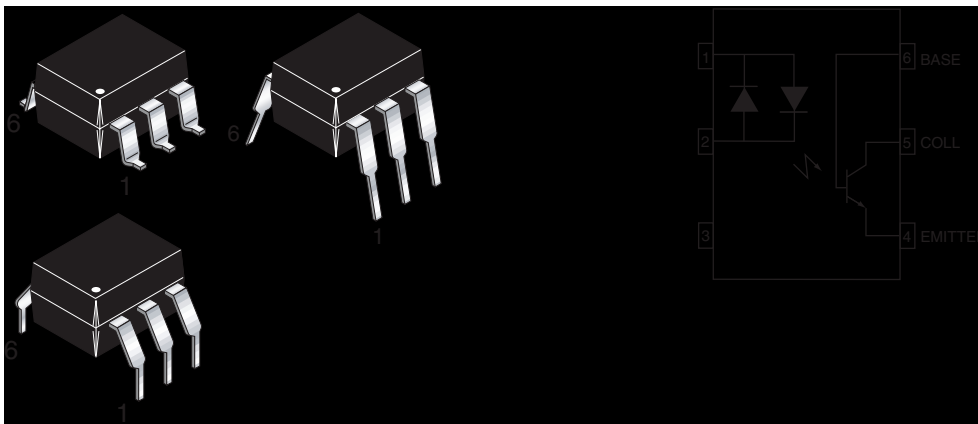

Parameter	Symbol	Device	Value	Units
TOTAL DEVICE				
Storage Temperature	T _{STG}	All	-55 to +150	°C
Operating Temperature	T _{OPR}	All	-55 to +100	°C
Lead Solder Temperature	T _{SOL}	All	260 for 10 sec	°C
Total Device Power Dissipation	P _D	All	350	mW
Derate Linearly From 25°C			4.6	mW/°C
EMITTER				
Continuous Forward Current	I _F	All	100	mA
Forward Current - Peak (1 μs pulse, 300 pps)	I _{F(pk)}	All	±1.0	A
LED Power Dissipation	P _D	All	200	mW
Derate Linearly From 25°C			2.6	mW/°C
DETECTOR				
Detector Power Dissipation	P _D	All	300	mW
Derate above 25°C			4.0	mW/°C

Electrical Characteristics ($T_A = 25^\circ\text{C}$ Unless otherwise specified.)

Individual Component Characteristics

Parameter	Test Conditions	Symbol	Device	Min	Typ	Max	Unit
EMITTER							
Input Forward Voltage	$I_F = \pm 10\text{ mA}$	V_F	All		1.2	1.5	V
Capacitance	$V_F = 0\text{ V}, f = 1.0\text{ MHz}$	C_J	All		80		pF
DETECTOR							
Breakdown Voltage Collector to Emitter	$I_C = 1.0\text{ mA}, I_F = 0$	BV_{CEO}	All	30			V
Collector to Base	$I_C = 100\text{ }\mu\text{A}, I_F = 0$	BV_{CBO}	All	70			V
Emitter to Base	$I_E = 100\text{ }\mu\text{A}, I_F = 0$	BV_{EBO}	All	5			V
Emitter to Collector	$I_E = 100\text{ }\mu\text{A}, I_F = 0$	BV_{ECO}	All	7			V
Leakage Current Collector to Emitter	$V_{CE} = 10\text{ V}, I_F = 0$	I_{CEO}	H11AA1,3,4 H11AA2			50 200	nA
Capacitance Collector to Emitter	$V_{CE} = 0, f = 1\text{ MHz}$	C_{CE}	All		10		pF
Collector to Base	$V_{CE} = 0, f = 1\text{ MHz}$	C_{CB}	All		80		pF
Emitter to Base	$V_{CE} = 0, f = 1\text{ MHz}$	C_{EB}	All		15		pF

Transfer Characteristics ($T_A = 25^\circ\text{C}$ Unless otherwise specified.)

Characteristics	Test Conditions	Symbol	Device	Min	Typ	Max	Units
Current Transfer Ratio, Collector to Emitter	$I_F = \pm 10\text{ mA}, V_{CE} = 10\text{ V}$	CTR_{CE}	H11AA4	100			%
			H11AA3	50			
			H11AA1	20			
			H11AA2	10			
Current Transfer Ratio, Symmetry	$I_F = \pm 10\text{ mA}, V_{CE} = 10\text{ V}$ (Figure.8)		All	.33		3.0	
Saturation Voltage Collector to Emitter	$I_F = \pm 10\text{ mA}, I_{CE} = 0.5\text{ mA}$	$V_{CE(SAT)}$	All			.40	V

Isolation Characteristics

Characteristic	Test Conditions	Symbol	Min	Typ	Max	Units
Package Capacitance input/output	$V_{I-O} = 0, f = 1\text{ MHz}$	C_{I-O}		0.7		pF
Isolation Voltage	$f = 60\text{ Hz}, t = 1\text{ min.}$	V_{ISO}	5300			VAC(RMS)
Isolation Resistance	$V_{I-O} = 500\text{ VDC}$	R_{ISO}	1011			Ω

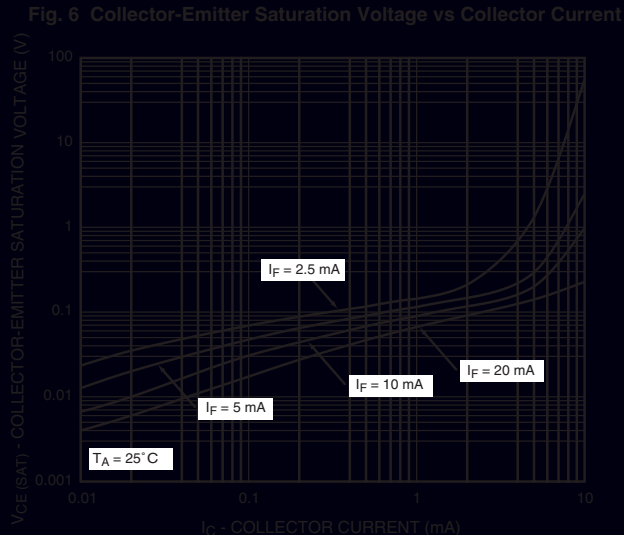
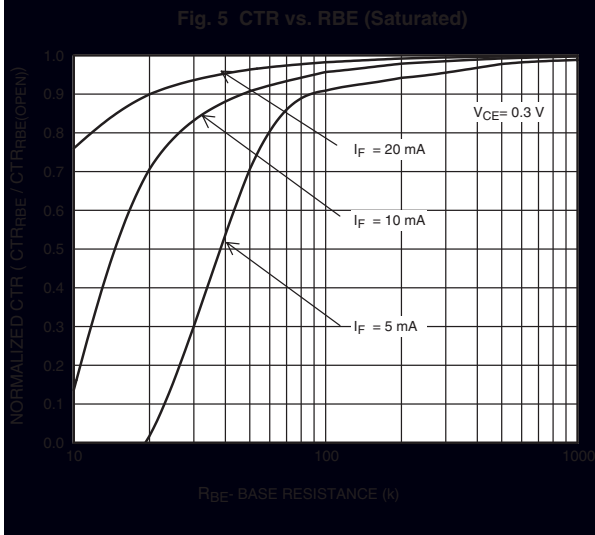
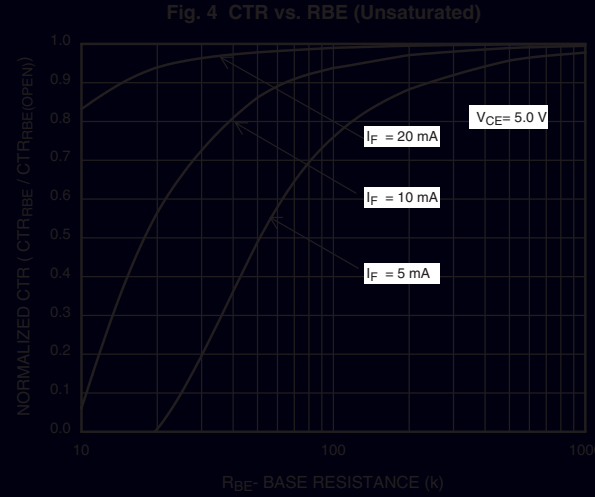
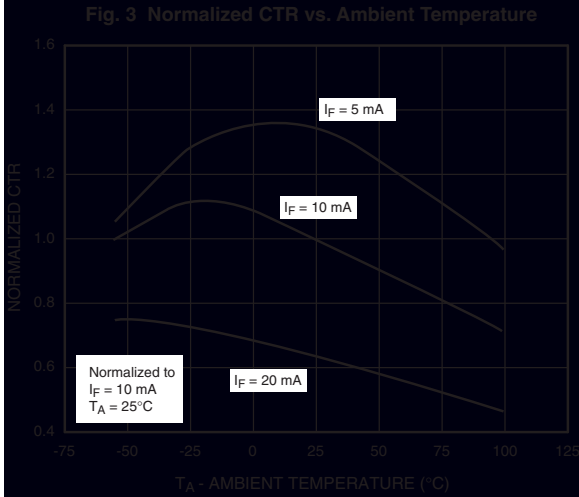
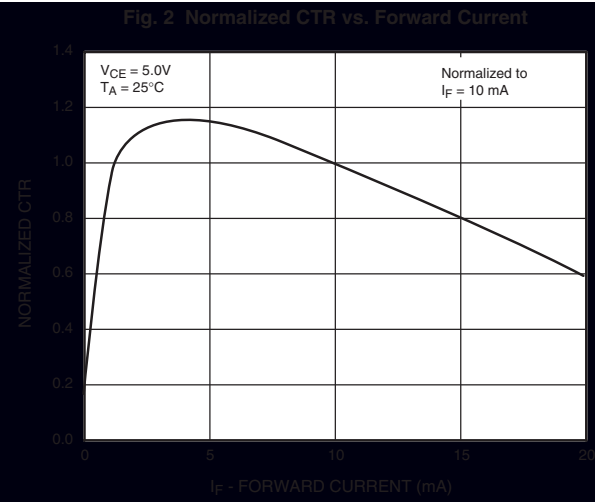
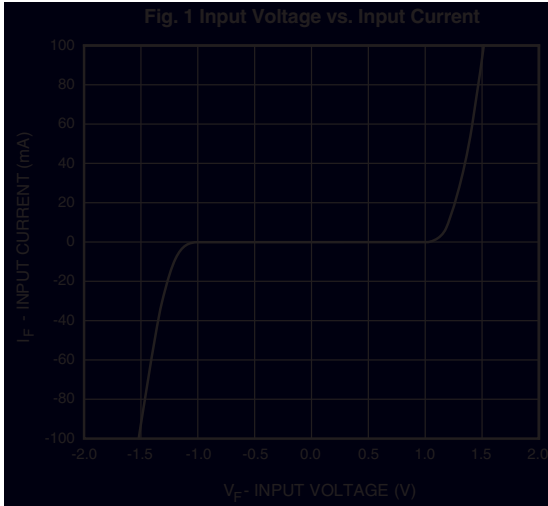

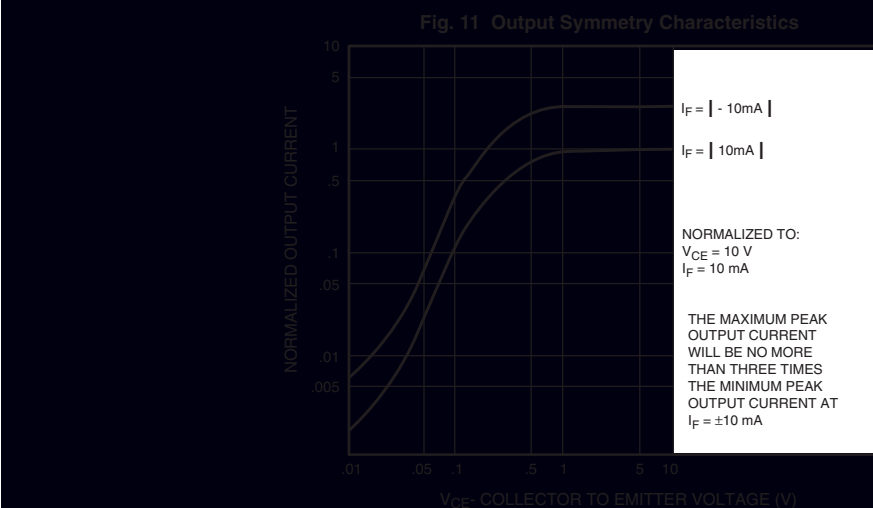
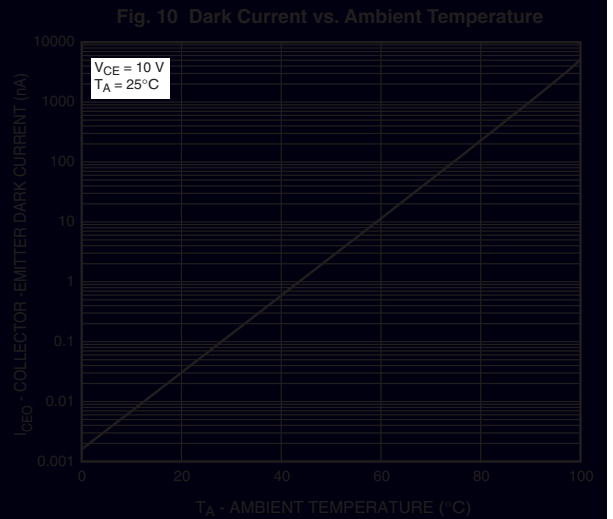
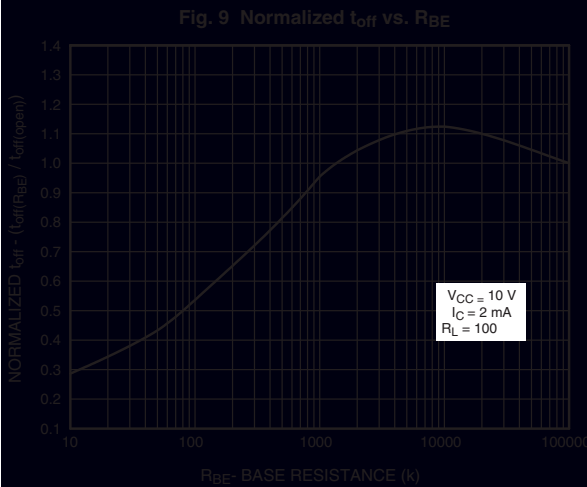
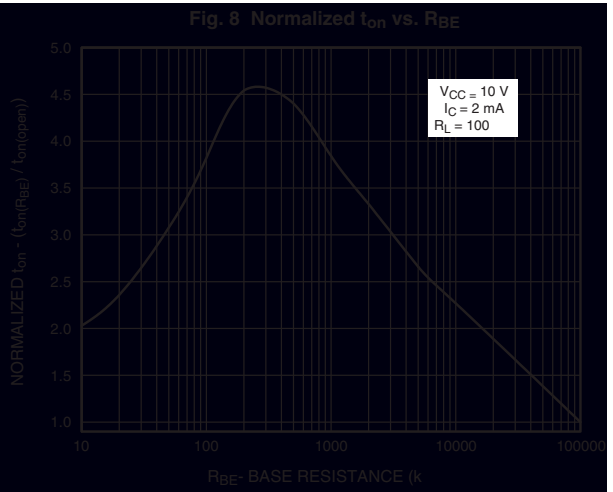
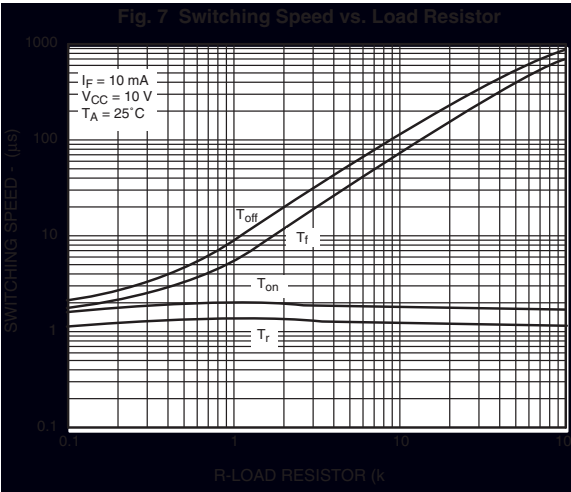

Package Dimensions (Through Hole)

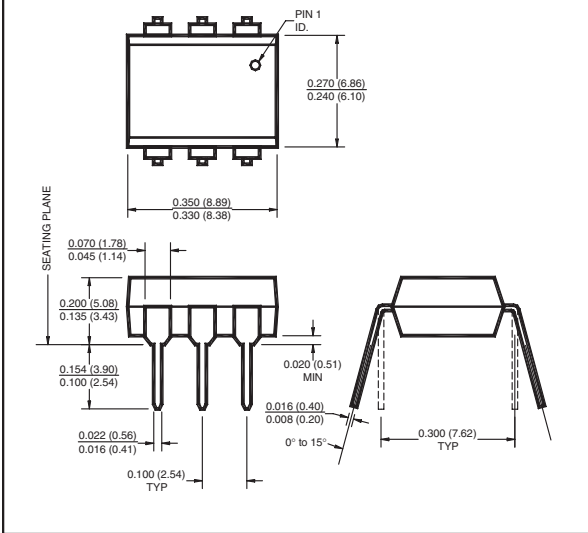

Package Dimensions (Surface Mount)

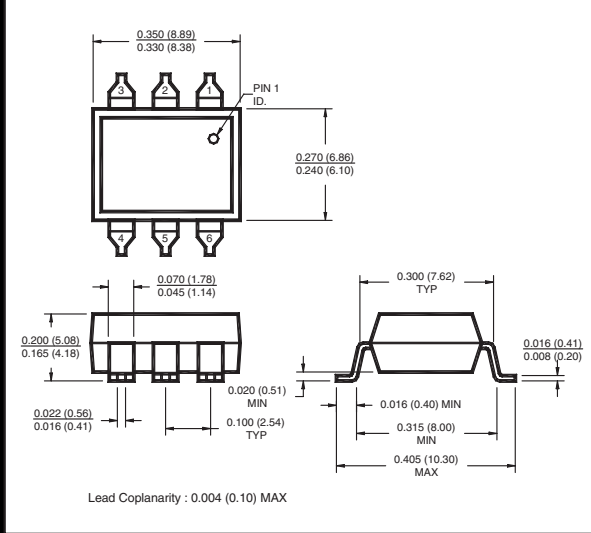

Package Dimensions (0.4" Lead Spacing)

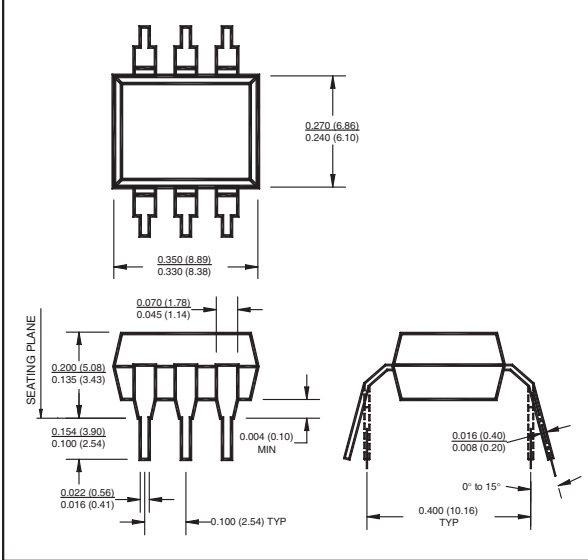

Recommended Pad Layout for Surface Mount Leadform

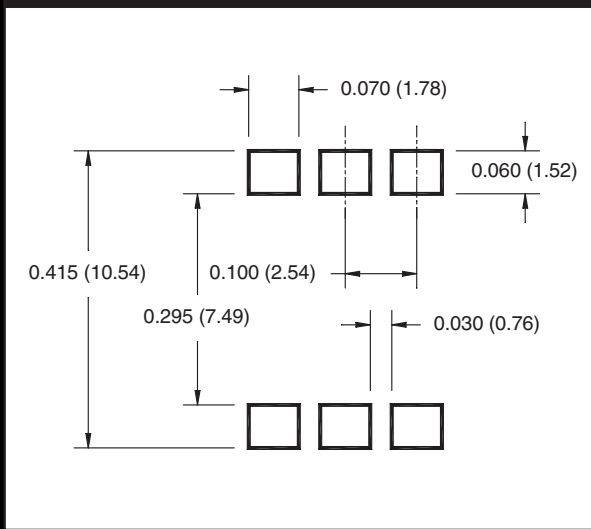

Note

All dimensions are in inches (millimeters)

Ordering Information

Option	Order Entry Identifier	Description
S	.S	Surface Mount Lead Bend
SD	.SD	Surface Mount; Tape and Reel
W	.W	0.4" Lead Spacing
300	.300	VDE 0884
300W	.300W	VDE 0884, 0.4" Lead Spacing
3S	.3S	VDE 0884, Surface Mount
3SD	.3SD	VDE 0884, Surface Mount, Tape and Reel

Carrier Tape Specifications ("D" Taping Orientation)

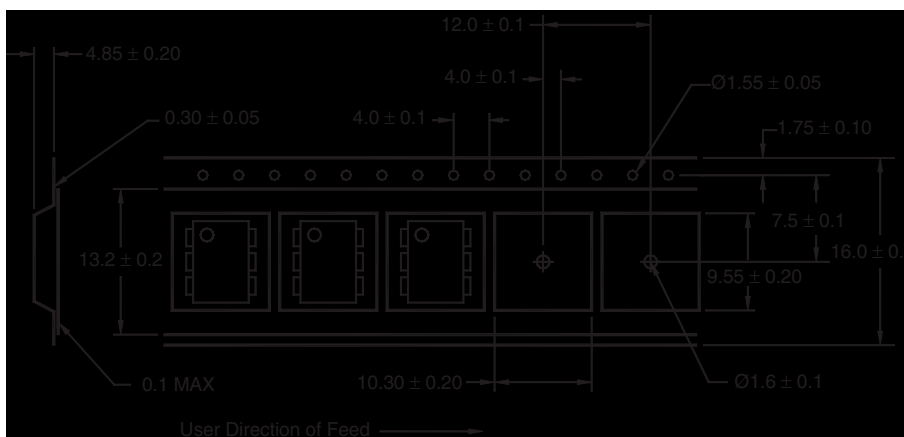

Note
All dimensions are in millimeters

Marking Information

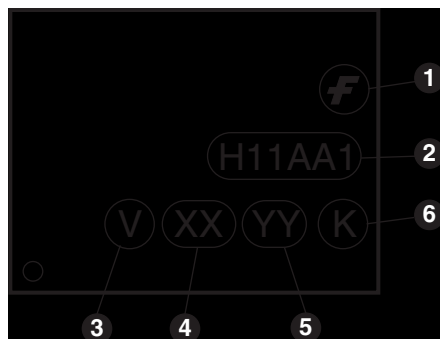

Definitions	
1	Fairchild logo
2	Device number
3	VDE mark (Note: Only appears on parts ordered with VDE option – See order entry table)
4	Two digit year code, e.g., '03'
5	Two digit work week ranging from '01' to '53'
6	Assembly package code

Reflow Profile (Black Package, No Suffix)

