

REV.	DATE	ECR NO.	DESCRIPTION
NC	05/12/11	XXXXXX	INITIAL RELEASE
A	06/23/11	2189	ADDED ±5° TOLERANCE FOR THE PARALLELISM OF THE SMA AND THE FLATS OF THE N CONNECTOR

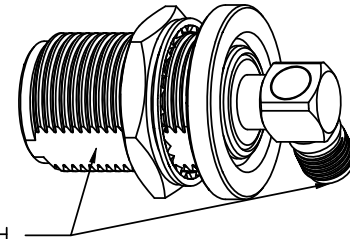

SCALE 0.500

ORIENT ACROSS FLATS WITH RESPECT TO SMA CONNECTOR AS SHOWN ±5°

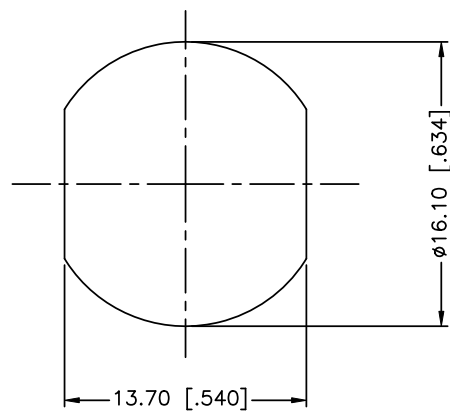
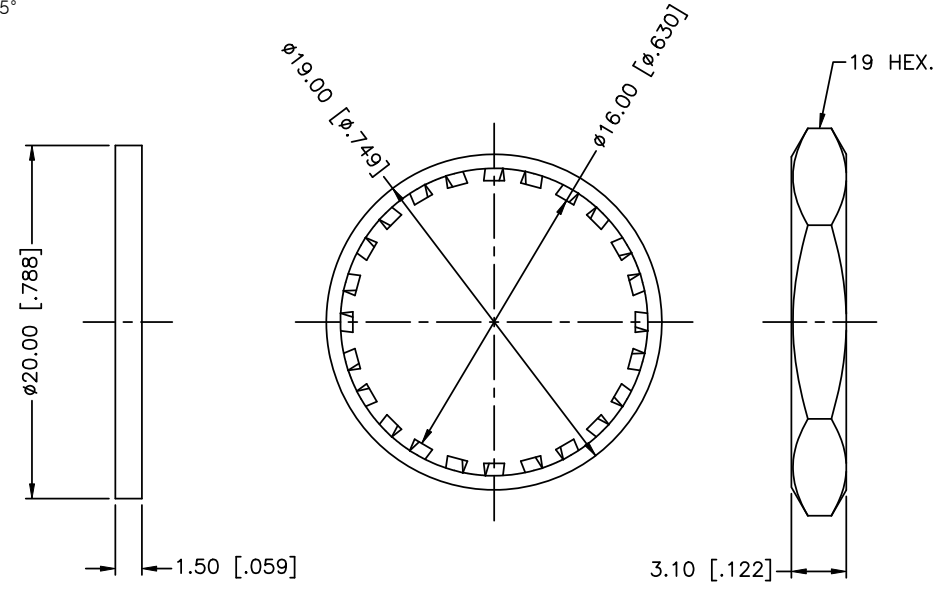
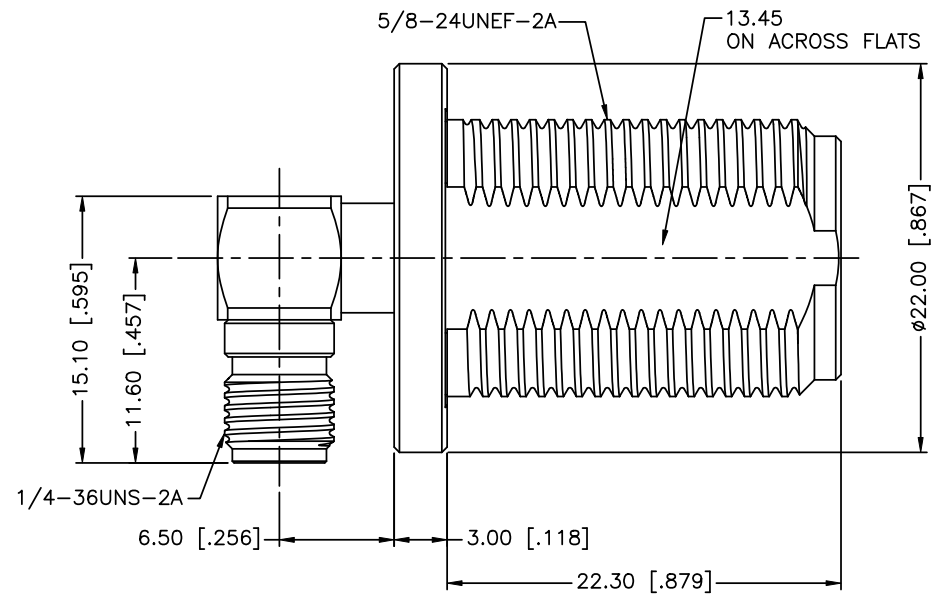

1. MAX. PANEL THICKNESS= 6.8mm

DESCRIPTION	MATERIAL	FINISH	QTY
9 COVER	BRASS	NICKEL	1
8 HEX NUT	BRASS	NICKEL	1
7 LOCK WASHER	BRASS	NICKEL	1
6 GASKET	SILICONE	RED	1
5 BODY	BRASS	NICKEL	1
4 CONTACT PIN	BER. COPPER	GOLD	1
3 O-RING	SILICONE	RED	1
2 INSULATOR	PTFE	NATURAL	1
1 HOUSING	BRASS	NICKEL	1

UNLESS OTHERWISE SPECIFIED DIMENSIONS ARE IN MILLIMETERS. DIMENSIONS IN [ ] ARE IN INCHES AND FOR CUSTOMER REFERENCE ONLY.

UNLESS OTHERWISE SPECIFIED TOLERANCES FOR MILLIMETERS ARE:  
0.5 - 8mm ± 0.20mm  
8 - 30mm ± 0.40mm  
30 - 120mm ± 0.50mm

UNLESS OTHERWISE SPECIFIED TOLERANCES FOR INCHES ARE:  
.020 - .315 = ± 0.007"  
.315 - 1.180 = ± 0.015"  
1.180 - 4.724 = ± 0.020"

DO NOT SCALE DRAWING

APPROVALS		DATE
DRAWN	T.DENG	06/23/11
CHECKED		
ISSUED		
SHEET	1 OF 1	
CAD FILE	C:/CONNEX/242253.DWG	

**Amphenol Connex**

PART DESCRIPTION  
**N BULKHEAD JACK TO SMA RIGHT ANGLE JACK ADAPTOR**

PART NO.  
**242253**

DWG. NO. 242253.DWG	REV. A	SIZE A	SCALE NA
---------------------	--------	--------	----------