

THIS DRAWING IS UNPUBLISHED. RELEASED FOR PUBLICATION
 © COPYRIGHT - By - ALL RIGHTS RESERVED.

LOC		DIST		REVISIONS			
P	LTR	DESCRIPTION		DATE	DWN	APVD	
GP	00	G		REVISED PER ECO-12-009966	30MAY2012	CJV	SLB

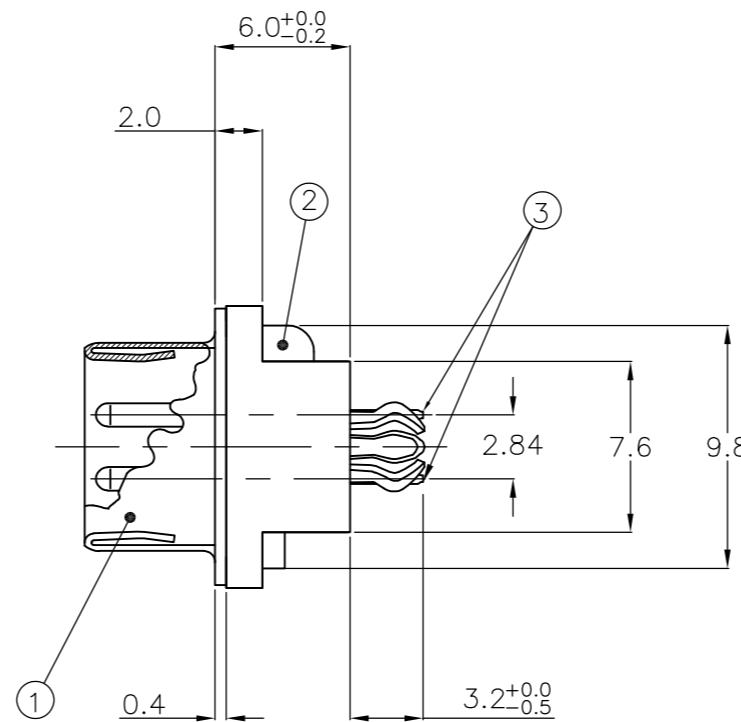
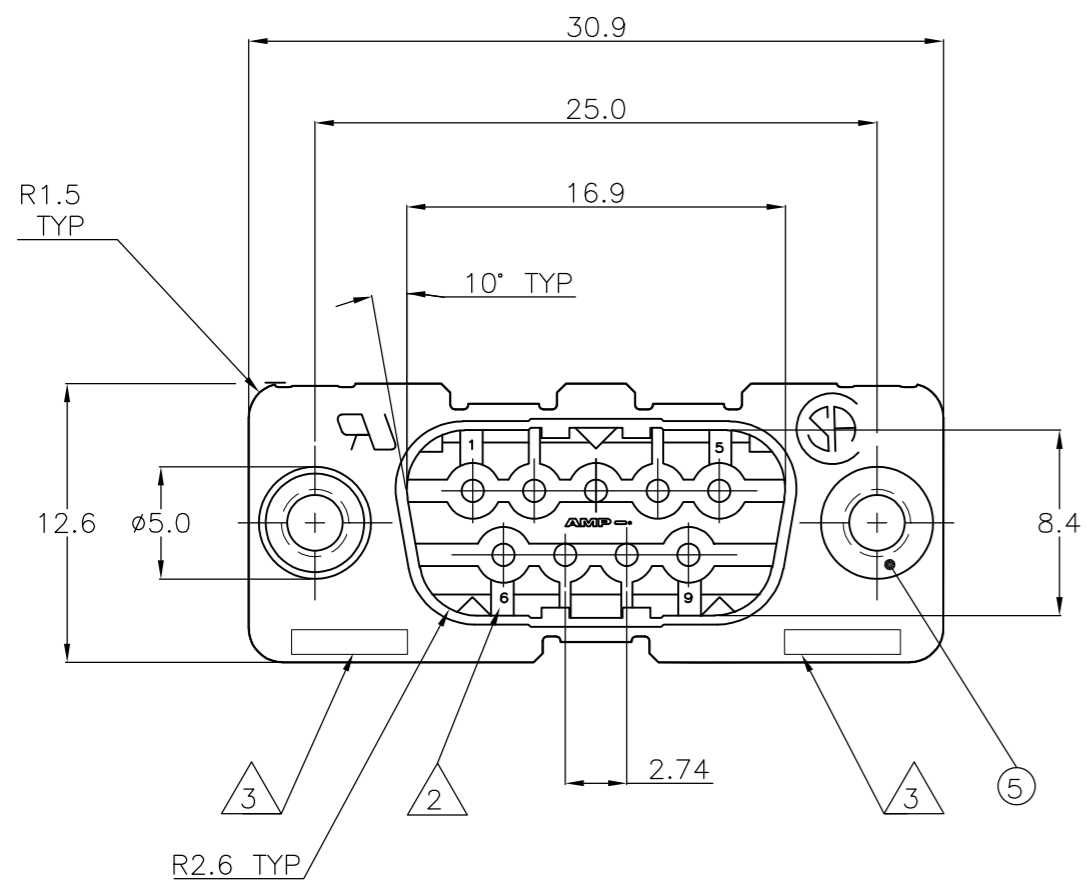

ITEM NO.	DESCRIPTION OF ACCESSORY	1	2	3	4	5	6	7	8	9
5	BUSHING WITH THROUGH HOLE Ø3.1									
5	BUSHING WITH THREAD 4-40 UNC		2						2	
5	BUSHING WITH THREAD M3			2						2
4	FEMALE SCREWLOCK WITH THREAD 4-40 UNC				2					2
4	FEMALE SCREWLOCK WITH THREAD M3					2				2
6	BOARDLOCK		2	2	2	2				

1-338309-2										
2-338309-2										
3-338309-2										
4-338309-2										
5-338309-2										
6-338309-2										
7-338309-2										
8-338309-2										OBSOLETE
9-338309-2										OBSOLETE

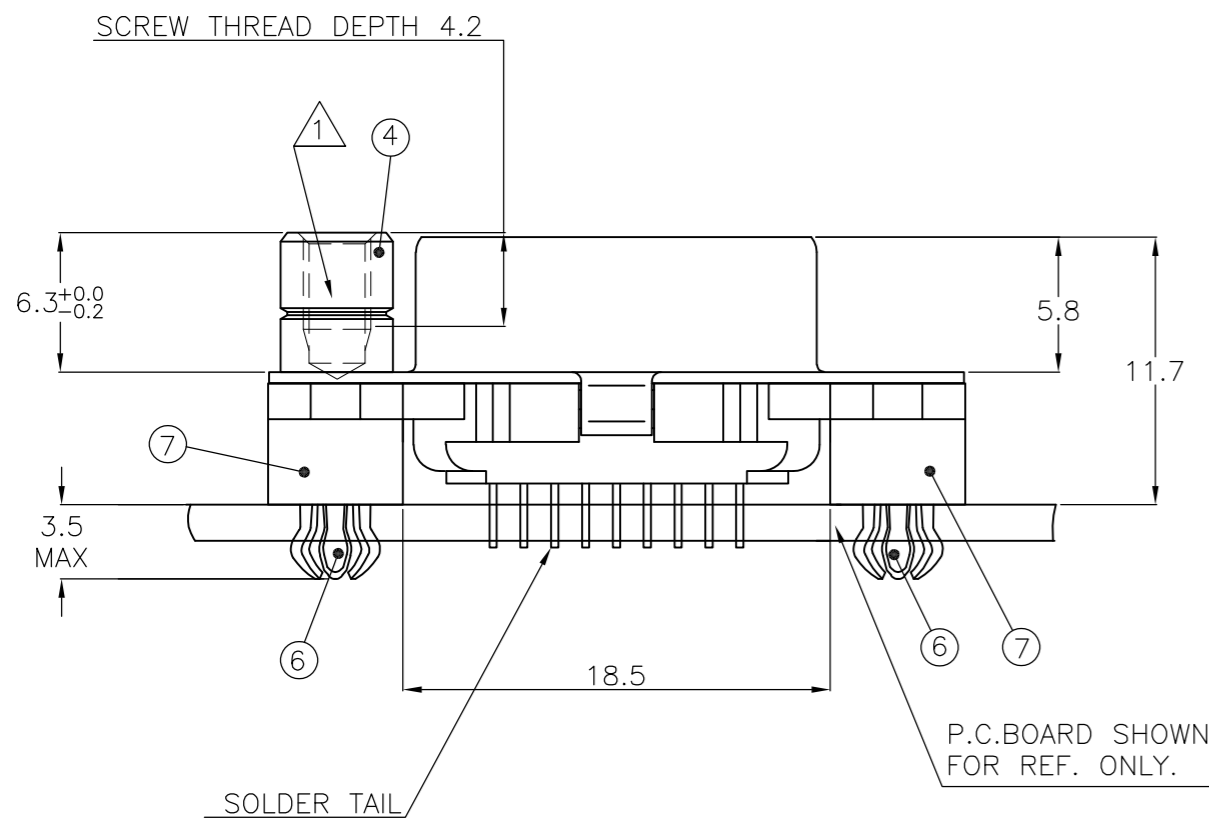

- ① GROOVE INDICATES VERSION WITH 4-40 UNC INNER THREAD; WITHOUT GROOVE INDICATES VERSION WITH M3 INNER THREAD.
- ② CAVITY IDENTIFICATION AT FRONT SIDE ONLY.
- ③ PART NUMBER AND DATE CODE.
- 4. WHEN BOARDLOCKS ARE USED, CONNECTOR CAN BE USED FOR PCB THICKNESS OF 1.6 mm ONLY.
- 5. SHELL HAS 2x2 GROUNDING SPRINGS; PITCH IS 3.6 mm.
- 6. AIR AND CREEPAGE DISTANCES ACCORDING TO DIN 41652.
- 7. CONTACT FINISH: GOLD FLASH OVER PALLADIUM-NICKEL PLATE OR GOLD PLATE ON THE MATING SURFACES, TIN PLATE ON THE SOLDER TAILS, NICKEL UNDERPLATE ON THE ENTIRE CONTACT. MATING SURFACE FINISH MEETS LEVEL 2 PER DIN 41652.

RECOMMENDED P.C. BOARD HOLE-LAYOUT

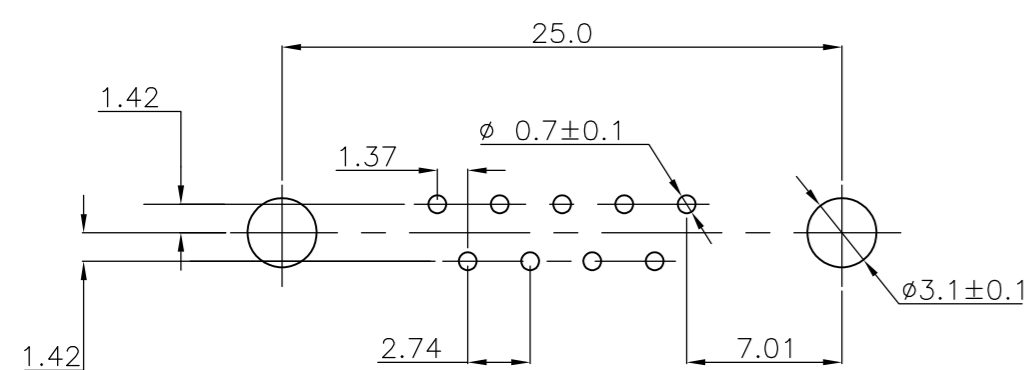

ITEM NO./MATERIAL :

- ① SHELL : BRIGHT TIN PLATED STEEL
- ② HOUSING : GLASS FILLED POLYESTER, COLOR : BLACK
- ③ CONTACTS : PHOSPHOR BRONZE (PLATING : SEE NOTES)
- ④ FEMALE SCREWLOCK : TIN PLATED STEEL (INNER THREAD 4-40 UNC OR M3)
- ⑤ BUSHING : TIN PLATED STEEL (INNER THREAD 4-40 UNC OR M3 OR Ø3.1 THROUGH HOLE)
- ⑥ BOARDLOCK : TIN PLATED PHOSPHOR BRONZE
- ⑦ STAND-OFF : GLASS FILLED NYLON COLOR : BLACK

THIS DRAWING IS A CONTROLLED DOCUMENT. DIMENSIONING AND TOLERANCING PER ASME Y14.5M-2009		DWN J.V. LIEMPT 03JUL97			HDP-20 SIZE 1 VERTICAL+ PLUG HEADER; WITH SOLDER CONTACTS	
DIMENSIONS: mm		CHK C. SOUISA 09SEP97			NAME	
TOLERANCES UNLESS OTHERWISE SPECIFIED:		APVD E. LEIJTENS 09SEP97	PRODUCT SPEC		SIZE A2	CAGE CODE 00779
0 PLC ± -		APPLICATION SPEC		DRAWING NO C=338309		REV G
1 PLC ± 0.3		WEIGHT -		SCALE NTS		SHEET 1 OF 1
2 PLC ± 0.15		CUSTOMER DRAWING		SCALE NTS		REV G
3 PLC ± -						
4 PLC ± -						
ANGLES ± -						
FINISH -						