

### DESCRIPTION

The EV26123-R-00A is an evaluation board for the MP26123, a high-performance 2-cell or 3-cell Li-ion battery switching charger with a built-in, internal power MOSFET.

The EV26123-R-00A achieves up to 2A of charge current across a wide input supply range. The charge current can be configured by sensing the current through an accurate sense resistor.

The MP26123 regulates the charge current and full-charge voltage using two control loops to achieve a high-accuracy constant current (CC) charge and constant voltage (CV) charge.

Fault protections include timeout control, full battery termination control, thermal protection, battery temperature monitoring, and protection. The board also indicates AC adapter power good, as well as the system's charge status.

### ELECTRICAL SPECIFICATIONS

Parameter	Symbol	Value	Units
Input voltage	$V_{IN}$	10 to 24	V
Charge current	$I_{CHG}$	2	A

### FEATURES

- Charges 2-Cell and 3-Cell Li-Ion Batteries
- Wide Operating Input Range
- Up to 2A Programmable Charging Current
- $\pm 0.75\%$   $V_{BATT}$  Accuracy
- Up to 90% Efficiency
- Fixed 600kHz Frequency
- Preconditioning for Full Depleted Batteries
- Charging Operation Indicator
- Input Supply and Battery Fault Indicator
- Thermal Shutdown
- Battery Temperature Monitoring and Protection

### APPLICATIONS

- Distributed Power Systems
- Chargers for 2-Cell or 3-Cell Li-Ion Batteries
- Pre-Regulator for Linear Regulators
- Smartphones
- Netbooks

All MPS parts are lead-free, halogen-free, and adhere to the RoHS directive. For MPS green status, please visit the MPS website under Quality Assurance. "MPS", the MPS logo, and "Simple, Easy Solutions" are trademarks of Monolithic Power Systems, Inc. or its subsidiaries.

### EV26123-R-00A EVALUATION BOARD



(LxWxH) 6.35cmx6.35cmx1.2cm

Board Number	MPS IC Number
EV26123-R-00A	MP26123DR

### 2-Cell Battery Charge Curve

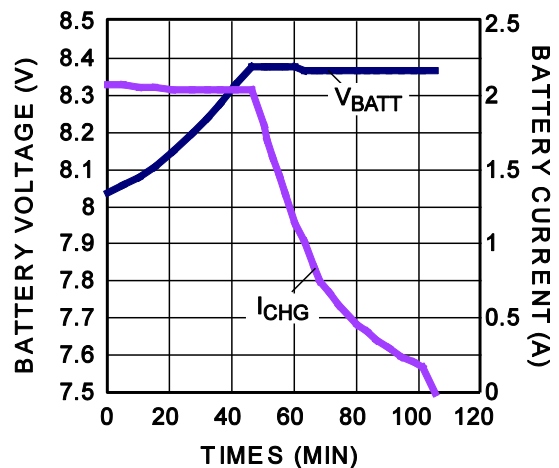

## QUICK START GUIDE

The EV26123-R-00A is used for the MP26123, which can be used as a standalone switching charger to charge 2-cell or 3-cell Li-ion batteries. The board layout accommodates most commonly used capacitors.

The default output voltage on this board is preset to 8.4V for 2-cell Li-ion batteries. Connect the CELLS pin to VREF33 to regulate the output to 12.6V for a 3-cell Li-ion battery.

The two LEDs operate as status indicators. If the input can charge the battery load, LED1 is on; otherwise, it is off. If the charging operation is normal, LED2 is on. LED2 turns off if any of the following events occur: battery full, NTC fault, timer out, thermal protection, or EN disabled. LED2 blinks if BATT is floating.

1. Configure the charge current using sense resistor RS2. The charge current can be calculated with Equation (1):

$$I_{\text{CHG}} (\text{A}) = \frac{200\text{mV}}{\text{RS2}(\text{m}\Omega)} \quad (1)$$

2. Preset the power supply output to 19V, then turn the power supply off.
3. Attach the power supply output to:
  - a. Positive (+): VCC
  - b. Negative (-): GND
4. Attach the battery terminals to:
  - a. Positive (+): BATT
  - b. Negative (-): GND
5. Turn the power supply on. The board should automatically start up if EN is pulled to GND.
6. To use the enable function, apply a digital input to the EN pin. Drive EN above 1.8V to turn the charger off; drive EN below 0.4V to turn the charger on.
7. For power path applications, the board requires an additional current-sensing circuit that includes the following components: the MP8110, RG1, RG2, C8, C9, RS1, M1, and M2. Contact an MPS FAE for additional customization. Refer to the MP26123 datasheet for more information.

# EVALUATION BOARD SCHEMATIC

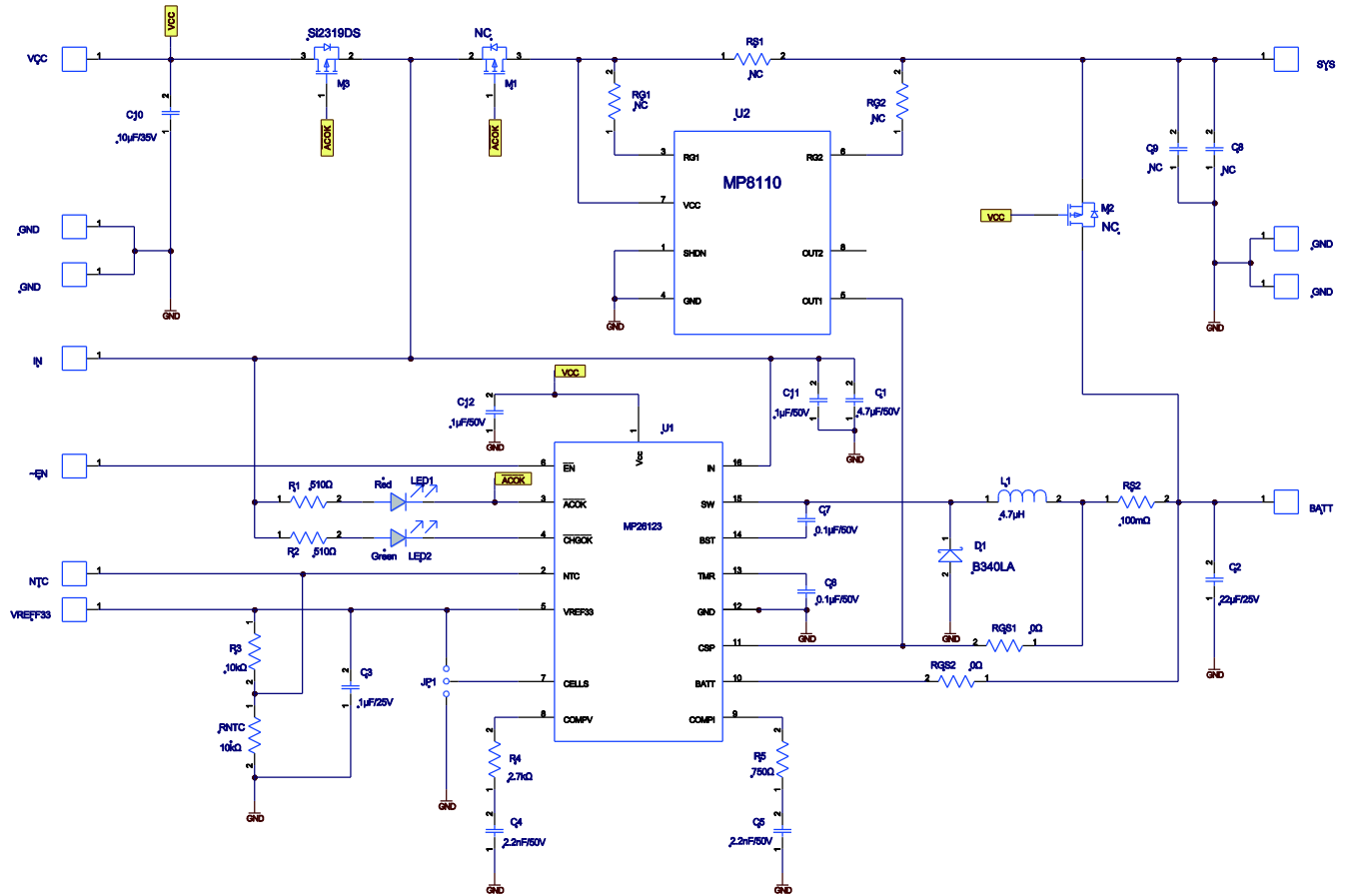

Figure 1: Evaluation Board Schematic

**EV26123-R-00A BILL OF MATERIALS**

Qty	Ref	Value	Description	Package	Manufacturer	Manufacturer P/N
1	C1	4.7μF	Ceramic capacitor, 50V, X7R	1210	Murata	GRM32ER71H475KA88L
1	C2	22μF	Ceramic capacitor, 25V, X5R	1210	Murata	GRM32ER61E226KE15L
1	C3	1μF	Ceramic capacitor, 25V, X5R	0603	TDK	C1608X5R1E105K
2	C4, C5	2.2nF	Ceramic capacitor, 50V, X7R	0603	TDK	C1608X7R1H222K
2	C6, C7	0.1μF	Ceramic capacitor, 50V, X7R	0603	Murata	GRM188R71H104KA93D
1	C10	10μF	Ceramic capacitor, 35V, X7R	1210	Murata	GRM32ER7YA106KA12L
2	C11, C12	1μF	Ceramic capacitor, 50V, X7R	0805	Murata	GRM21BR71H105KA12L
2	R1, R2	510Ω	Film resistor, 5%	0805	LIZ	0805J510R
1	R3	10kΩ	Film resistor, 1%	0603	Royal Ohm	0603F1002T5E
1	R4	2.7kΩ	Film resistor, 5%	0603	LIZ	CR0603JA0272K
1	R5	750Ω	Film resistor, 1%	0603	Yageo	RC0603FR-07750RL
2	RGS1, RGS2	0Ω	Film resistor, 5%	0603	Yageo	RC0603JR-070RL
1	RS2	100mΩ	Film resistor, 1%	2512	Cyntec	RL-3624-9-R100-FN
1	RNTC	10kΩ	Film resistor, 1%	0603	Royal Ohm	0603F1002T5E
1	JP1		3-pin connector header, 0.100"		Sullins	PTC03SAAN
1	LED1	Green	Green surface-mount LED	0805	Bright LED	BL-HGE35A-AV-TRB
1	LED2	Red	Red surface-mount LED	0805	Bright LED	BL-HUE35A-AV-TRB
1	D1	Schottky diode	Schottky diode, 40V, 3A	SMA	Diodes	B340LA-13F
1	L1	4.7μH	Inductor, 6A, 19.5mΩ	SMD	Würth	744311470
			Inductor, 3.8A, 38mΩ	SMD	Toko	DS84LC-B1015AS-4R7N
			Inductor, 5.2A, 18mΩ	SMD	Murata	LQH88PN4R7N38
			Inductor, 3.78A, 29.7mΩ	SMD	Cooper	DR73-4R7-R
1	M1,	40V/2.4A	PMOS, 130mΩ	SOT23	Vishay	Si2319DS
1	U1	MP26123	Switching charger	QFN-16 (4mmx4mm)	MPS	MP26123DR
1	U2	NC				
1	RS1	NC				
2	RG1, RG2	NC				
2	C8, C9	NC				
2	M2, M3	NC				

### PCB LAYOUT

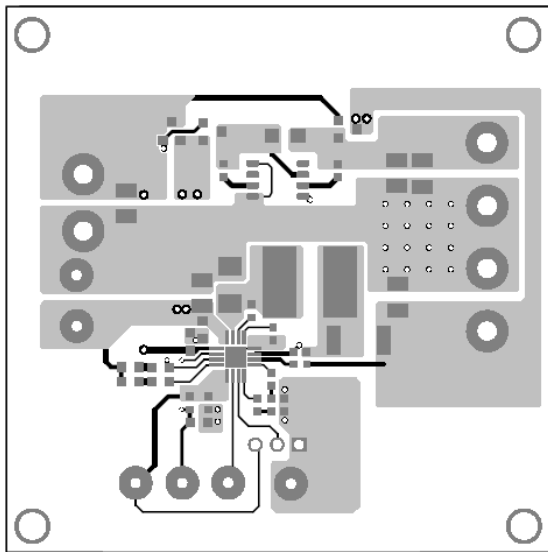

Figure 2: Top Layer

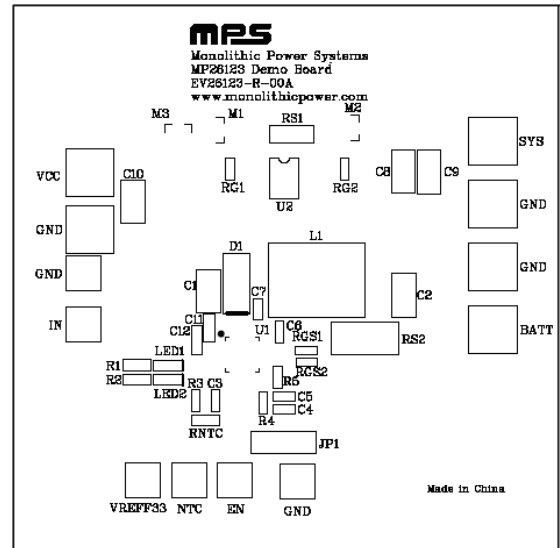

Figure 3: Top Silk Layer

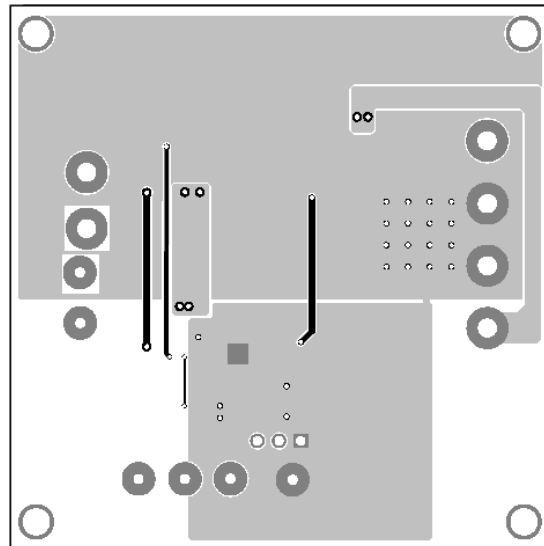

Figure 4: Bottom Layer

## Revision History

Revision #	Revision Date	Description	Pages Updated
1.0	7/29/2020	Initial Release	-

**Notice:** The information in this document is subject to change without notice. Please contact MPS for current specifications. Users should warrant and guarantee that third-party Intellectual Property rights are not infringed upon when integrating MPS products into any application. MPS will not assume any legal responsibility for any said applications.