

# TRIO-UPS-2G/1AC/1AC/230V/ 750VA

## Uninterruptible power supply



Data sheet  
107056\_en\_00

© PHOENIX CONTACT 2017-04-18

## 1 Description

The TRIO-UPS-2G uninterruptible power supply (UPS) is used to ensure that power for critical electrical loads continues to be supplied in the event of disturbances in the power supply network, e.g., due to mains breakdown or failure.

In doing so, the UPS switches to battery operation without interruption so that connected loads continue to be consistently supplied.

When mains power is restored, the UPS automatically returns to normal operation. The connected loads are again supplied via the power supply network and the battery is charged.

The product described here is an uninterruptible power supply (UPS) with integrated energy storage (2 x 3.4 Ah).

### Features

- Offline UPS in line with UPS classification code according to IEC 62040-3: VFD-SS-311
- Waveform Type: pure sine
- Optimum use of the buffer time and preventive battery monitoring
- Maximum energy efficiency: 95 % efficiency for charged energy storage device
- Startup from energy storage possible without mains input
- USB interface for connection to higher-level controllers, such as industrial PCs
- Can be extended with external energy storage (1 x 24 V, 3.4 Ah)

### Technical data (short form)

Input voltage range	184 V AC ... 264 V AC
Frequency range	45 Hz ... 55 Hz
Nominal output voltage ( $U_N$ )	230 V AC
Nominal output current ( $I_N$ )	3 A
Apparent power	750 VA
Nominal power (real power)	600 W
Buffer period	20 min. (100 W) 4 min. (300 W) 1 min. (600 W)
Efficiency with charged power storage device	> 95 %
MTBF (IEC 61709, SN 29500)	> 206000 h (40°C)
Ambient temperature (operation)	0 °C ... 40 °C
Dimensions W/H/D	210 mm / 170 mm / 136 mm
Weight	5.7 kg
Battery technology	Lead rechargeable battery module
Battery type	2x Panasonic UP-VW1220P1
Capacitance	3.4 Ah
Battery fuse	40 A, 32 V
Can be extended with external battery	yes, 1x 24 V / 3.4 Ah



Make sure you always use the latest documentation.  
It can be downloaded from the product at [phoenixcontact.net/products](https://phoenixcontact.net/products).

<b>2</b>	<b>Table of contents</b>	
1	Description .....	1
2	Table of contents .....	2
3	Ordering data .....	3
4	Technical data .....	4
5	Safety regulations and installation notes.....	10
	5.1 Symbols used .....	10
	5.2 Safety and warning notes .....	10
6	Structure .....	12
	6.1 Function elements .....	12
	6.2 Device dimensions and keepout areas .....	13
	6.3 Block diagram.....	14
7	Mounting/removing the uninterruptible power supply .....	15
	7.1 Convection.....	15
	7.2 Normal mounting position .....	15
	7.3 Mounting the uninterruptible power supply .....	15
	7.4 Removing the uninterruptible power supply .....	16
	7.5 Retrofitting the universal wall adapter .....	16
	7.6 Installation of individual components .....	17
8	Device connection .....	18
	8.1 Connecting the internal power storage .....	18
	8.2 Push-in connection technology .....	18
	8.3 AC input .....	19
	8.4 AC output .....	19
	8.5 Battery 24V .....	19
9	Device operation .....	20
	9.1 Rotary selector switch .....	20
	9.2 Setting the buffer time .....	20
	9.3 PC mode .....	20
	9.4 Service mode .....	22
	9.5 Changing the internal energy storage .....	22
	9.6 Remote contact.....	22
	9.7 Battery start (Bat.-Start).....	23
10	Signaling.....	23
	10.1 LED indicators and signal outputs .....	24
11	Interface .....	25
	11.1 USB interface MINI type B .....	25
12	Derating.....	25
	12.1 Ambient temperature .....	25
	12.2 Installation height.....	25

### 3 Ordering data

Description	Type	Order No.	Pcs./Pkt.
1AC/1AC/750 VA uninterruptible power supply with integrated energy storage, lead AGM, VRLA technology, 24 V DC, 3.4 Ah for 230 V AC applications.	TRIO-UPS-2G/1AC/1AC/230V/750VA	2905909	1
Accessories	Type	Order No.	Pcs./Pkt.
Energy storage device, lead AGM, VRLA technology, 24 V DC, 3.4 Ah. Connection via pin cable lug, 14 mm.	QUINT-BAT/24DC/ 3.4AH	2866349	1
Used for communication between an industrial PC and Phoenix Contact devices with USB-Mini-B connection.	MINI-SCREW-USB-DATACABLE	2908217	1
2-piece universal wall adapter for securely mounting the power supply in the event of strong vibrations. The profiles that are screwed onto the side of the power supply are screwed directly onto the mounting surface. The universal wall adapter is attached on the left/right.	UWA 130	2901664	1
Fuse, nominal current: 10 A, length: 31.8 mm, diameter: 6.35 mm	FUSE 10A/400V GRL	2908358	1
Fuse, nominal current: 40 A, length: 19 mm, width: 5 mm, height: 18.8 mm	FUSE 40A/32V ATOF	2908357	2



Our range of accessories is being continually extended, our current range can be found in the download area.

## 4 Technical data

### Input data

Nominal input voltage	230 V AC
Input voltage range	184 V AC ... 264 V AC
Frequency range	45 Hz ... 55 Hz
Current draw	3 A
Permissible backup fuse	B6 / B10 / B16

### Input connection data

Connection method	Push-in connection
Conductor cross section, solid	0.2 mm <sup>2</sup> ... 4 mm <sup>2</sup>
Conductor cross section, flexible	0.2 mm <sup>2</sup> ... 2.5 mm <sup>2</sup>
Conductor cross section AWG/kcmil	24 ... 12
Stripping length	10 mm

### Output data

Apparent power	750 VA
Nominal power (real power)	600 W
Power factor (cos phi)	0.8
Crest factor	2.8
Switch-over time	< 10 ms
Classification according to IEC 62040-3	VFD-SS-311

### Output data (mains operation)

Nominal output voltage (U <sub>N</sub> )	230 V AC
Nominal output current (I <sub>N</sub> )	3 A ( at 750 VA )

### Output data (battery operation)

Nominal output voltage (U <sub>N</sub> )	230 V AC
Nominal output current (I <sub>N</sub> )	3 A ( at 750 VA )
Form of output voltage	Pure sine

### Output connection data

Connection method	Push-in connection
Conductor cross section, solid	0.2 mm <sup>2</sup> ... 4 mm <sup>2</sup>
Conductor cross section, flexible	0.2 mm <sup>2</sup> ... 2.5 mm <sup>2</sup>
Conductor cross section AWG/kcmil	24 ... 12
Connection method	10 mm

**Energy storage**

Battery technology	Lead rechargeable battery module
Battery type	2x Panasonic UP-VW1220P1
Capacitance	3.4 Ah
Battery fuse	40 A, 32 V
Charging time	7 h
Service life	6 ... 9 (20 °C)
Latest startup	6 Months ( 0 °C ... 20 °C ) 6 Months ... 3 Months ( 20 °C ... 30 °C ) 3 Months ... 1 Months ( 30 °C ... 40 °C )
Buffer time	100 W / 20 min. ; 300 W / 4 min. ; 600 W / 1 min.
Can be extended with external battery	yes , 1x 24 V / 3.4 Ah

**Connection data for the external battery**

Connection method	Push-in connection
Conductor cross section, solid	0.2 mm <sup>2</sup> ... 10 mm <sup>2</sup>
Conductor cross section, flexible	0.2 mm <sup>2</sup> ... 6 mm <sup>2</sup>
Conductor cross section AWG/kcmil	24 ... 8
Stripping length	15 mm

**Status and diagnostic indicators/signal outputs Alarm**

Switching output	Transistor output, active
Output voltage	24 V (SELV)
Continuous load current	≤ 20 mA
Status display	LED ( red )

**Status and diagnostic indicators/signal outputs Battery Mode**

Switching output	Transistor output, active
Output voltage	24 V (SELV)
Continuous load current	≤ 20 mA
Status display	LED ( yellow )

**Status and diagnostic indicators/signal outputs Ready**

Switching output	Transistor output, active
Output voltage	24 V (SELV)
Continuous load current	≤ 20 mA

**Status and diagnostic indicators/signal outputs Battery Charge**

Status indication	LED ( yellow )
-------------------	----------------

**Status and diagnostic indicators/signal outputs AC OK, P>P<sub>n</sub>, Remote**

Status indication	LED ( green )
-------------------	---------------

**Status and diagnostic indicators/signal outputs Service**

Status indication	LED ( red )
-------------------	-------------

<b>Signal connection data</b>	
Connection method	Push-in connection
Conductor cross section, solid	0.2 mm <sup>2</sup> ... 1.5 mm <sup>2</sup>
Conductor cross section, flexible	0.2 mm <sup>2</sup> ... 1.5 mm <sup>2</sup>
Conductor cross section AWG/kcmil	24 ... 16
Stripping length	8 mm
<b>Remote control ( Remote )</b>	<b>Digital control input (configurable)</b>
Low signal	Connection to SGnd with < 2.7 kΩ
High signal	Open (> 35 kΩ between remote and SGnd)
<b>Battery-operated start (bat. start)</b>	<b>Digital control input low-active</b>
Low signal	Connection to SGnd with < 2.7 kΩ
High signal	Open (> 200 kΩ between bat. start and SGnd)
<b>Interfaces</b>	
USB classification	MINI-USB type B
<b>Device combinations</b>	
UPS connection in parallel	no
UPS connection in series	no
<b>General data</b>	
Efficiency	95 % ( with charged power storage device )
MTBF	> 206000 h (40°C)
Degree of protection	IP20
Protection class	I
Type of housing	DX51D+AZ (steel sheet / Galvalume)
Hood version	PC + ABS
Input fuse	10 A , 400 V , gRL
Dimensions W/H/D (normal mounting position/delivered condition)	210 mm / 170 mm / 136 mm
Weight	5.7 kg
<b>Ambient conditions</b>	
Ambient temperature (operation)	0 °C ... 40 °C
Ambient temperature (storage/transport)	-15 °C ... 40 °C (with charged power storage device)
Max. permissible relative humidity (operation)	≤ 95 % (25°C, non-condensing)
Installation height	≤ 3000 m (> 2000 m, observe derating)
Vibration (operation)	5 Hz ... 100 Hz, 0.7g (EN 60068-2-6)
Shock	20g in all directions (EN 60068-2-27) 30g in each space direction with UWA 130
Degree of pollution	2
Climatic class	3K3 (in acc. with EN 60721)

**Standards**

Uninterruptible power supply

EN 62040-1



Current approvals/permissions for the product can be found in the download area under [phoenixcontact.net/products](http://phoenixcontact.net/products).

**Electromagnetic compatibility**

**Noise emission according to EN 62040-2 (Class C2)**

Conducted noise emission	EN 62040-02 (Class C2)
Noise emission	EN 62040-02 (Class C2)
Harmonic currents	EN 61000-3-2 (Class A)

**Noise immunity according to EN 62040-2-2006**

CE basic standard	Minimum normative requirements of EN 62040-2 (immunity for industrial environments)	Requirements in practice (covered)
<b>Electrostatic discharge EN 61000-4-2</b>		
Housing contact discharge	4 kV (Test Level 2)	6 kV (Test Level 3)
Housing air discharge	8 kV (Test Level 3)	8 kV (Test Level 3)
Comments	none	none
<b>Electromagnetic HF field EN 61000-4-3</b>		
Frequency range	80 MHz ... 1 GHz	80 MHz ... 3 GHz
Test field strength	10 V/m	10 V/m
Comments	Criterion A	Criterion A
<b>Fast transients (burst) EN 61000-4-4</b>		
Input	2 kV (Test Level 3 - asymmetrical)	2 kV (Test Level 3 - asymmetrical)
Output	2 kV (Test Level 3 - asymmetrical)	2 kV (Test Level 3 - asymmetrical)
Signal	2 kV (Test Level 3 - asymmetrical)	2 kV (Test Level 3 - asymmetrical)
Comments	Criterion B	Criterion A (B for USB)
<b>Surge current loads (surge) EN 61000-4-5</b>		
Input	1 kV (Test Level 2 - symmetrical) 2 kV (Test Level 3 - asymmetrical)	1 kV (Test Level 2 - symmetrical) 2 kV (Test Level 3 - asymmetrical)
Output	1 kV (Test Level 2 - symmetrical) 2 kV (Test Level 3 - asymmetrical)	1 kV (Test Level 2 - symmetrical) 2 kV (Test Level 3 - asymmetrical)
Signal	1 kV (Test Level 2 - asymmetrical)	1 kV (Test Level 2 - asymmetrical)
Comments	Criterion B	Criterion A
<b>Conducted interference EN 61000-4-6</b>		
Frequency range	0.15 MHz ... 80 MHz	0.15 MHz ... 80 MHz
Voltage	10 V	10 V
Comments	Criterion A	Criterion A



Noise immunity according to EN 62040-2-2006		
CE basic standard	Minimum normative requirements of EN 62040-2 (immunity for industrial environments)	Requirements in practice (covered)
Power frequency magnetic field EN 61000-4-8	50 Hz ( 30 A/m )	50 Hz ( 100 A/m )
Comments	Criterion B	Criterion A

Key	
Criterion A	Normal operating behavior within the specified limits.
Criterion B	Temporary impairment to operational behavior that is corrected by the device itself.



All technical specifications are nominal and refer to a room temperature of 25 °C and 70% relative humidity at 2000 m above sea level.

## 5 Safety regulations and installation notes

### 5.1 Symbols used

Instructions and possible hazards are indicated by corresponding symbols in this document.



This is the safety alert symbol. It is used to alert you to potential personal injury hazards. Obey all safety measures that follow this symbol to avoid possible personal injuries.

There are different categories of personal injury that are indicated by a signal word.



**WARNING**  
This indicates a hazardous situation which, if not avoided, could result in death or serious injury.



**CAUTION**  
This indicates a hazardous situation which, if not avoided, could result in minor or moderate injury.



**NOTE**  
Indication of a required action which if it is not performed may cause damage or malfunction to the device, hardware/software, or surrounding property.



This symbol and the accompanying text provide the reader with additional information or refer to detailed sources of information.

### 5.2 Safety and warning notes



**WARNING: Danger to life by electric shock!**

- Only professionals may install, start up, and operate the device.
- Never carry out work when voltage is present.
- Establish connection correctly and ensure protection against electric shock.
- Connect the protective conductor device terminal block ⊕ with ground.
- Operation of the device is only permitted in mains network systems with grounded neutral conductor. This mainly complies with the TN-C-S mains network type. National regulations must be observed.
- Cover termination area after installation in order to avoid accidental contact with live parts (e. g., installation in control cabinet).
- This unit receives power from more than one source - Disconnection of AC source and the energy storage is required to de-energize this unit before servicing.
- Keep flames, embers or sparks away from the module.
- When connecting the internal batteries, observe the polarity and do not short circuit the pole terminals.
- Provide a switch/circuit breaker close to the device at the AC input, AC output and at the battery terminals, which are labeled as the disconnecting device for this device.
- Do not disconnect the fuse and / or battery connection under Hazloc conditions.
- The batteries are maintenance free and may not be opened.
- Use copper cables for operating temperatures of >75 °C.



**CAUTION: Hot surface**  
Depending on the ambient temperature and load on the uninterruptible power supply, the housing can become hot.

**NOTE**

- Observe the national safety and accident prevention regulations.
- Assembly and electrical installation must correspond to the state of the art.
- The uninterruptible power supply is a built-in device. The protection class IP20 of the device is meant to be applied in a clean and dry environment.
- The device must be installed in a control cabinet that can be locked and only opened by specialist staff.
- Horizontal mounting position (normal mounting position)
- Observe mechanical and thermal limits.
- Ensure sufficient convection (minimum gap above/below: 50 mm). Housing can become hot.
- Ensure that the primary-side wiring and secondary-side wiring are the correct size and have sufficient fuse protection.
- You can find the connection parameters, such as the necessary stripping length for the wiring with and without ferrule, in the associated table.
- Protect the device against foreign bodies penetrating it, e.g., paper clips or metal parts.
- To reduce the risk of fire, replace only with same type and rating of fuse.
- To reduce the risk of fire, connect only to a circuit provided with the following maximum branch circuit overcurrent protection in accordance with the National Electric Code, ANSI/NFPA 70.
- The uninterruptible power supply is maintenance-free. Repairs may only be carried out by the manufacturer. The warranty no longer applies if the housing is opened.
- The uninterruptible power supply may only be used for its intended use.
- Improper use invalidates the device protection.
- Only use batteries from the same batch when replacing the internal batteries.
- When storing the module, observe the latest startup date of the battery module and recharge, if necessary.
- Before transporting the uninterruptible power supply, always disconnect the battery connecting cable from a battery contact or remove the DC fuse in the battery compartment.

**More follows**

- Use current-limited source or suitable fuse.
- The switching outputs are active outputs according to SELV. These may only be operated on permitted SELV circuits.
- Keep these instructions in a safe place – this data sheet contains important safety notes which must be observed during installation and maintenance of the device and batteries.

6 Structure

6.1 Function elements

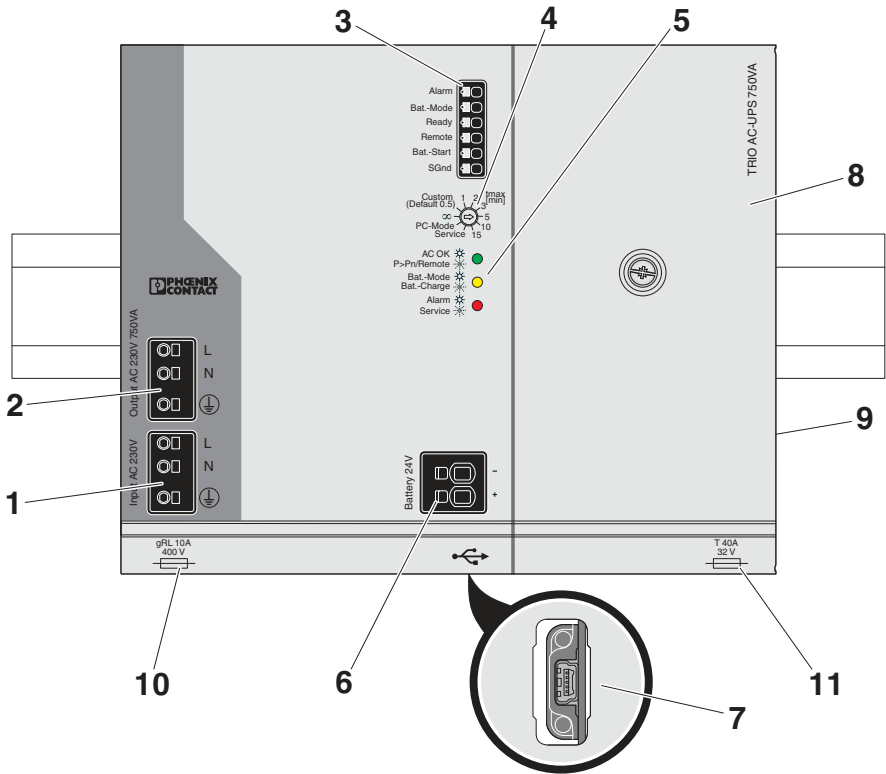

Figure 1 Position of the function elements (part 1)

Key

No.	Designation
1	Connection terminal blocks for AC input
2	Connection terminal blocks for AC outputs
3	Signaling connection terminal blocks
4	Rotary selector switch
5	LED signaling
6	Connection terminal blocks for external energy storage
7	USB interface MINI type B (bottom of device)
8	Power storage cover
9	Universal DIN rail adapter (rear of housing)
10	Input fuse
11	Battery fuse

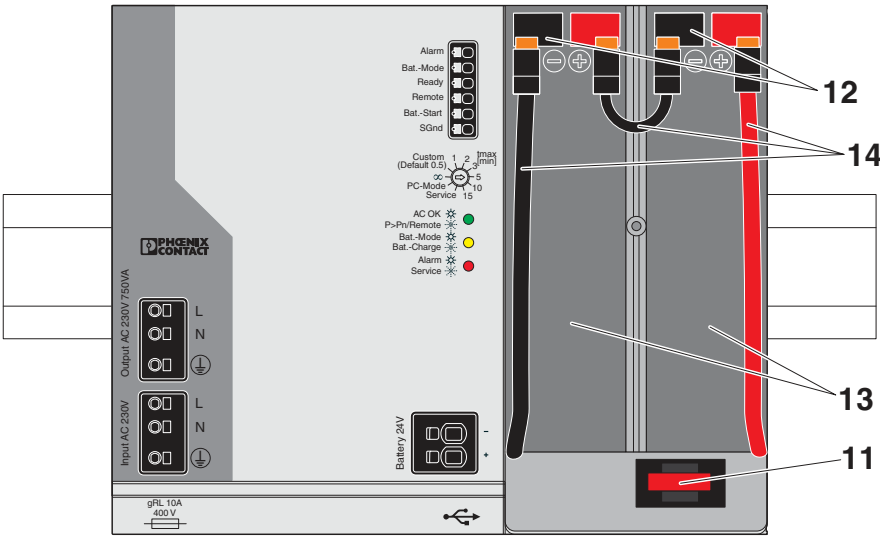

Figure 2 Position of the function elements (part 2)

Key

No.	Designation
11	Battery fuse
12	Power storage connection contacts
13	Energy storage
14	Battery connecting cables

6.2 Device dimensions and keepout areas

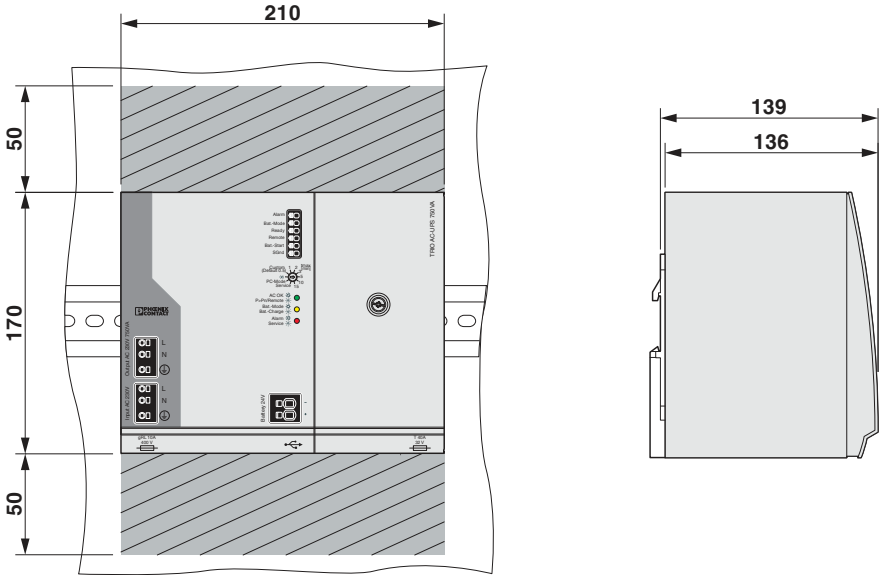
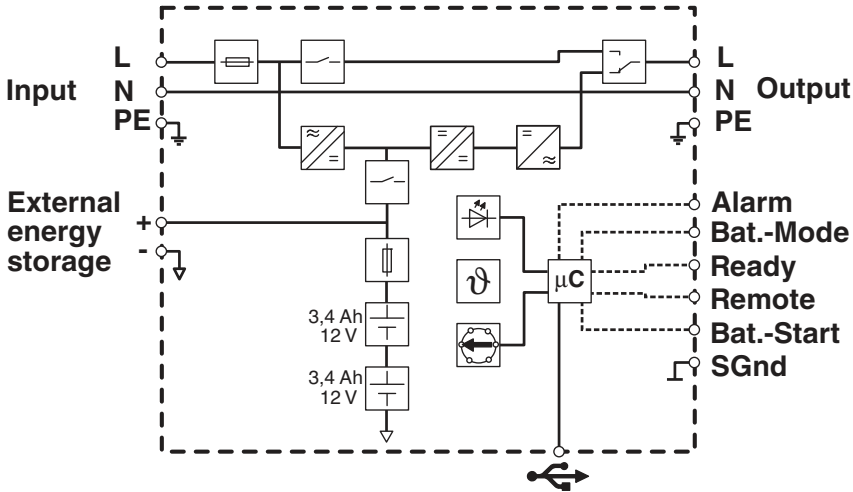

Figure 3 Device dimensions and keepout areas

6.3 Block diagram



Element	Meaning
	Microprocessor
	LED
	Battery module
	Switch
	Temperature sensor
	Selector switch
	Fuse
	Rectifier with electrical isolation
	DC/DC converter with electrical isolation
	Inverter
	Changeover switch

# 7 Mounting/removing the uninterruptible power supply



**NOTE**  
The device must be installed in a control cabinet that can be locked and only opened by specialist staff.

## 7.1 Convection



**NOTE: enable convection**  
The housing can become very hot, depending on the ambient temperature and module load. In order to ensure sufficient convection, we recommend a minimum vertical distance of 50 mm to the other devices.

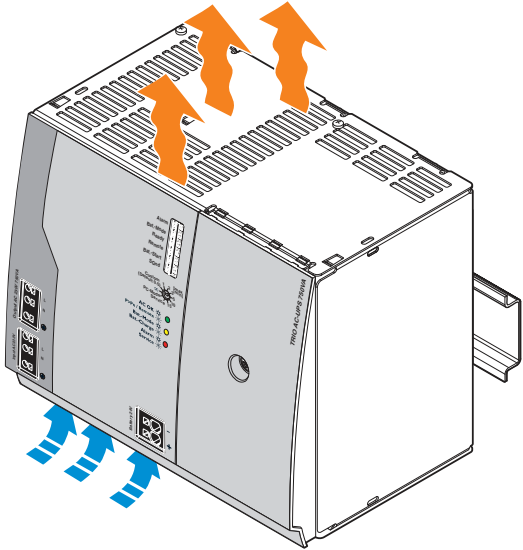

Figure 4 Convection

## 7.2 Normal mounting position



The device can be snapped onto all DIN rails according to EN 60715 and should only be mounted in the normal mounting position.

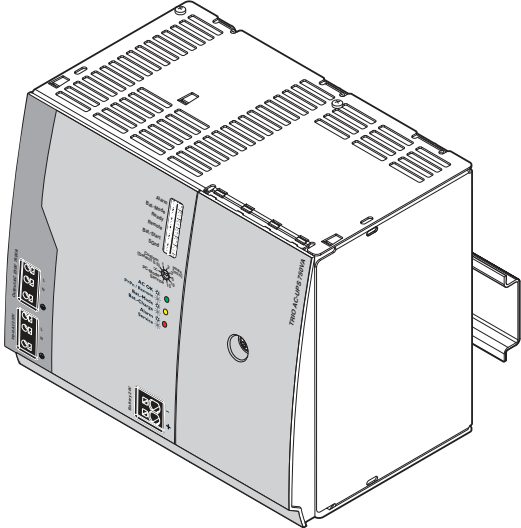

Figure 5 Normal mounting position

## 7.3 Mounting the uninterruptible power supply

Proceed as follows to mount the device:

1. In the normal mounting position the device is mounted on the DIN rail from above. Make sure that the universal DIN rail adapter is in the correct position behind the DIN rail (A).
2. Then press the device down until the universal DIN rail adapter audibly latches into place (B).
3. Check that the device is securely attached to the DIN rail.

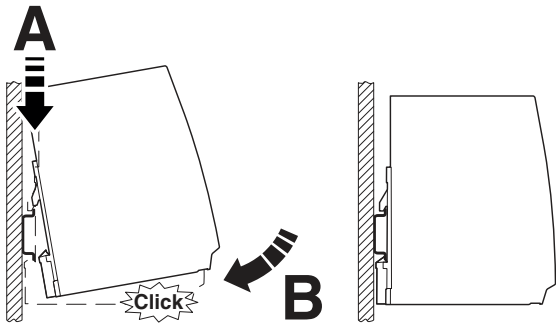

Figure 6 Snapping onto the DIN rail

#### 7.4 Removing the uninterruptible power supply

Proceed as follows to remove the device:

1. Take a suitable screwdriver and insert this into the lock hole on the universal DIN rail adapter (A).
2. Release the lock by lifting the screwdriver (B).
3. Carefully swivel the device forward (C) so that the lock slides back into the starting position.
4. Then separate the device from the DIN rail (D).

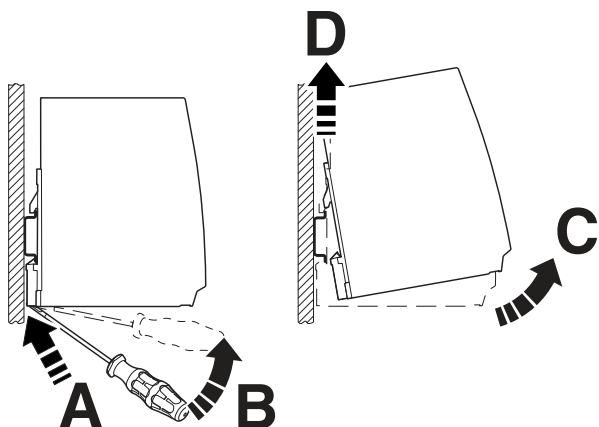

Figure 7 Removing from the DIN rail

#### 7.5 Retrofitting the universal wall adapter

The UWA 130 universal wall adapter (Order No. 2901664) is used to attach the uninterruptible power supply directly to the mounting surface.

The use of the universal wall adapter is recommended under extreme ambient conditions, e.g., strong vibrations. Thanks to the tight screw connection between the uninterruptible power supply and the universal wall adapter or the actual mounting surface, an extremely high level of mechanical stability is ensured.



The UWA 130 is attached to the uninterruptible power supply by means of the Torx screws of the universal wall adapter.

The maximum tightening torque of the Torx screw (Torx® T10) is 0.7 Nm.

Make sure you use suitable mounting material when attaching to the mounting surface.

#### 7.5.1 Mounting the UWA 130 2-piece universal wall adapter

Proceed as follows to disassemble the universal DIN rail adapter that comes pre-mounted:

1. Remove the screws for the universal DIN rail adapter using a suitable screwdriver (Torx 10).
2. Remove the universal DIN rail adapter from the rear of the uninterruptible power supply.

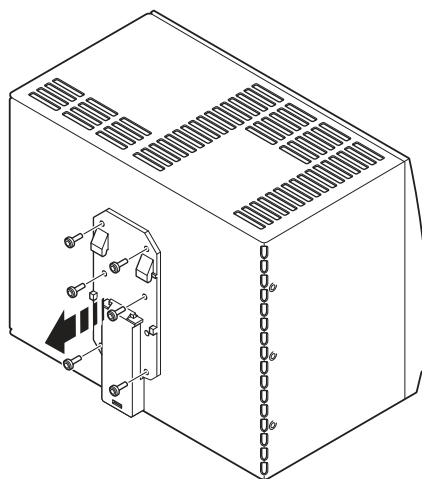

Figure 8 Disassembling the universal DIN rail adapter

1. Screw the two-piece universal wall adapter onto the uninterruptible power supply.

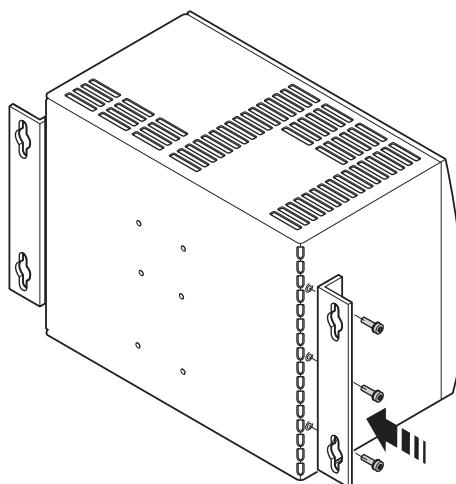



Figure 9 Mounting the UWA 130 universal wall adapter



7.6 Installation of individual components

Installation of uninterruptible power supply units must correspond to EN 60950 regulations.

 **WARNING**  
Provide a switch/circuit breaker close to the device at the AC input, AC output and at the battery terminals, which are labeled as the disconnecting device for this device.

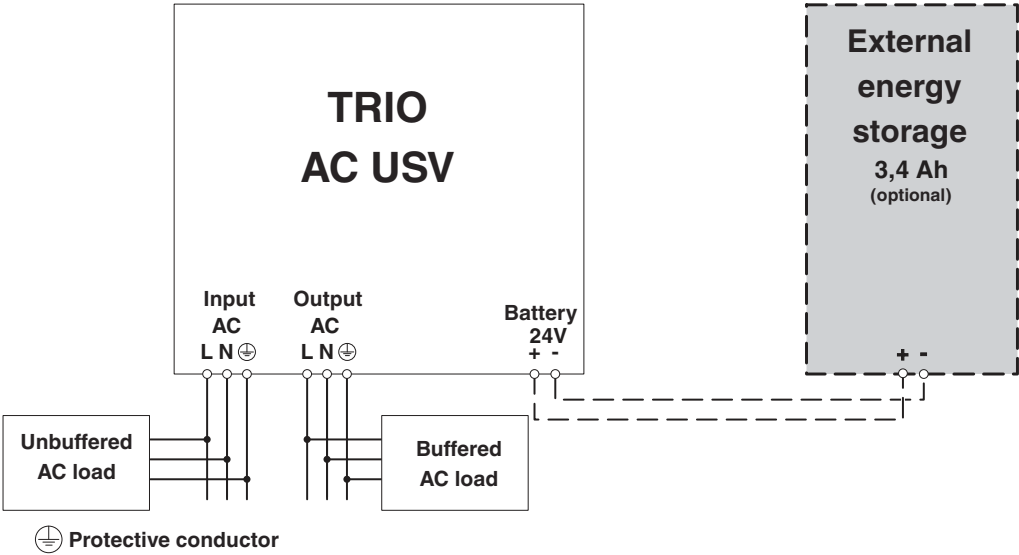



Figure 10 Schematic design

 The image is a schematic representation of the design and does not contain all parts. Observe the installation instructions.

 **NOTE**  
As so-called wear parts, batteries are not provided with a warranty. Deep discharge and storage beyond the permitted temperature range lead to irreversible damage to batteries. To ensure a long service life for the batteries and high system availability at high output powers or a high number of discharge cycles to be expected, use an optional external battery.

## 8 Device connection

### 8.1 Connecting the internal power storage



#### NOTE

Prior to commissioning the device, connect the battery connection cable to the free battery contact.



#### WARNING

When connecting the internal batteries take note of the polarity.  
Do not short circuit the pole terminals.

#### 8.1.1 Connecting the battery connection cable

1. Open the battery compartment using a suitable screwdriver.
2. Connect the battery connection cable to the free battery contact.
3. Close the cover of the battery compartment.

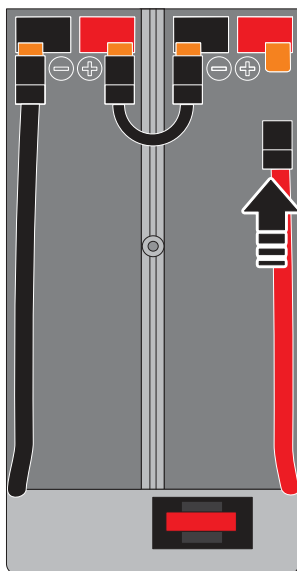

Figure 11 Connecting the battery connection cable

### 8.2 Push-in connection technology

The connection terminal blocks have a front-side push-in connection design. The wiring of the uninterruptible power supply is performed by plugging in, without tools.

#### 8.2.1 Plug in connecting cable

The wiring is carried out by simply plugging the connecting cable into the contact opening provided. Insert the connecting cable as far as it will go.

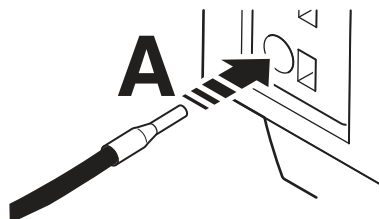

Figure 12 Insert connecting cable (push-in connection technology)

#### 8.2.2 Loosen the connecting cable

To disconnect the wiring, take a suitable screwdriver and insert it into the opening for release. Then carefully pull the connecting cable out of the contact opening.

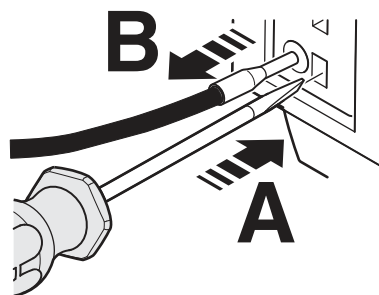

Figure 13 Release connecting cable (push-in connection technology)

**8.3 AC input**

The supply voltage is connected via "Input AC" connection terminal blocks.

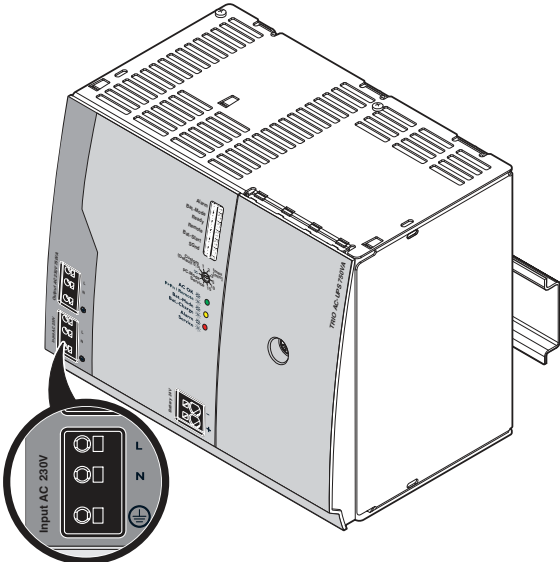

Figure 14 Connection terminal blocks, AC input



If loads must not be supplied in the event of a mains voltage dip or failure, they must be connected directly to the input of the uninterruptible power supply as an unbuffered AC load.

**8.5 Battery 24V**

In addition to the internal power storage you also have the option of connecting external power storage.

The external power storage is connected via the "Battery 24V" connection terminal blocks.

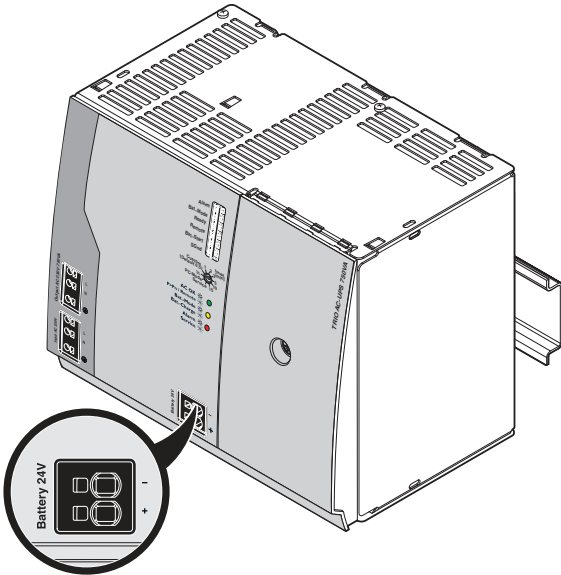

Figure 16 Connection terminal blocks Battery 24V

**8.4 AC output**

Buffered output voltage is connected via "Output AC" connection terminal blocks.

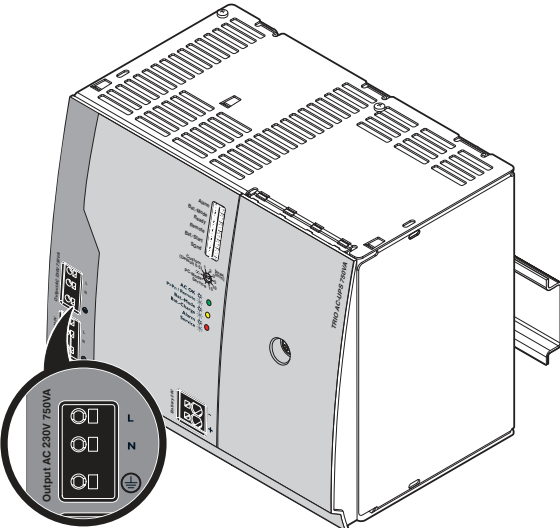



Figure 15 Connection terminal blocks, AC output

## 9 Device operation

### 9.1 Rotary selector switch

You can set the following functions via the rotary selector switch on the front of the device:

- Buffer period
- PC mode
- Service mode

 Use a suitable screwdriver to set the rotary selector switch.

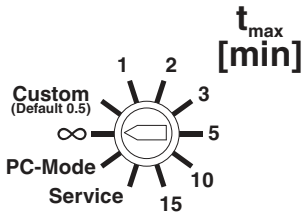

Figure 17 Rotary selector switch

### 9.2 Setting the buffer time

Rotary selector switch setting	Meaning
1, 2, 3, 5, 10, 15	The UPS switches off after the set buffer time.
Custom (default 0.5)	The UPS switches off after the individual buffer time set via UPS-CONF. If a buffer time is not set, the UPS shuts down after 30 seconds.
∞ (unlimited, delivery state)	Buffering with the total stored energy. An alarm is generated as soon as the voltage of the energy storage falls below 20.4 V (default).

Refer to the following diagram for possible buffer times for varying discharge capacity.

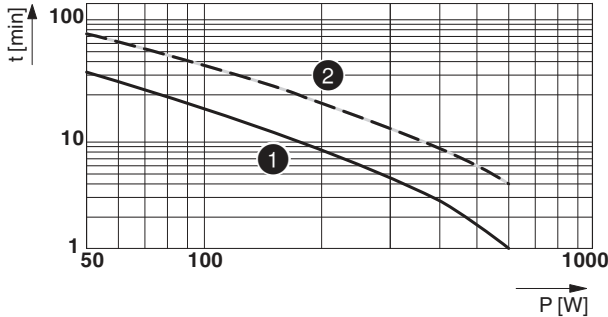



Figure 18 Buffer time/discharge current diagram

- 1 with internal energy storage
- 2 with internal and external optional energy storage

### 9.3 PC mode

In PC mode, you can individually parameterize the chronological sequence of the UPS functions via the UPS-CONF configuration software.

To access the PC mode of the UPS, set the rotary selector switch to PC mode.

 The following components are required for the PC mode function:  
Data cable MINI-SCREW-USB-DATACABLE (Order No. 2908217)  
Configuration software UPS-CONF (Order No. 2320403)

In the event of a mains failure, one PC can continue to work, perform a controlled shutdown, and restart automatically.

Example: a software backup starts which ensures successive backup of system data.

**1. Delay time**

If the mains supply is not restored during the delay time, the PC is shut down.

**3. PC shutdown**

The time required for PC shutdown is set here.

**2. Program start**

After the delay time has expired, it is possible to start a program.

**4. PC idle time**

Only if the PC is shut down and the mains supply is restored in the meantime is the output voltage interrupted for the reset time and the PC then started automatically.

The screenshot shows the 'UPS-CONF' software interface for a TRIO-UPS-2G/1AC/1AC/230V/750VA. The 'Time Setting' tab is active in the sidebar. The main configuration area contains the following settings:

- 1 Time based Shutdown Delay:** 03:15 h:mm:ss (Max.: 2 h)
- 2 Program Startup if „Shutdown Delay“ expired:**  enable  
Max. Program Runtime: 01:00 mm:ss (Max.: 5 min)  
Program path: [Browse ...]  
Program arguments: <Arguments> [Test]
- 3 PC-Shutdown:** 00:10 mm:ss (Max.: 5 min)  
Countdown (15 seconds) till PC-Shutdown:  enable
- 4 PC-Restart Delay:** 10 seconds (Max.: 60 seconds)

Below the settings is a graph showing the relationship between input voltage ( $U_{in}$ ), PC output voltage ( $U_{PC}$ ), and output voltage ( $U_{out}$ ) over time ( $t$ ). The graph is divided into four numbered regions: 1 (mains failure), 2 (shutdown delay), 3 (program execution), and 4 (restart delay).

The status bar at the bottom shows 'Operation Mode: PC-Mode' and four indicators: Power Source (Mains), Battery Condition (Charged), Device Status (UPS OK), and Connection to UPS (Online).

Figure 19 Time setting

### 9.4 Service mode

When working in a system, it may be necessary to switch the uninterruptible power supply unit over to service mode.

To access the Service mode of the UPS, set the rotary selector switch to Service.



In this operating mode, DC battery connection terminal blocks are deactivated using software. The active signal output is always activated when the unit is switched over to service mode.

### 9.5 Changing the internal energy storage



**WARNING**

When connecting the batteries take note of the polarity.  
Do not short circuit the pole terminals.



**WARNING**

The batteries are maintenance free and may not be opened.



**NOTE**

When replacing batteries, always use new batteries from the same production batch.



**NOTE**

When storing the battery modules, observe the latest startup date and recharge, if necessary. The batteries may only be recharged in an uninterruptible power supply.

1. Set the rotary selector switch to Service.
2. Unscrew the screw connection of the battery compartment on the front of the UPS. Use a suitable screwdriver to do this.
3. Remove the cover of the battery compartment.
4. Disconnect the battery connecting cable connectors from the battery contacts.
5. Carefully remove the batteries from the housing.
6. Carefully insert new batteries into the housing.
7. Connect the battery connecting cable connectors to the battery contacts.
8. Close the cover of the battery compartment.
9. Fix the cover by tightening the screw using the screwdriver.
10. Exit Service mode.
11. Set the buffer time or PC mode.

### 9.5.1 Notes on disposal



Do not dispose of the UPS and battery modules in household waste! They should be disposed of according to the currently applicable national regulations.



You can return used batteries and accumulators to Phoenix Contact or the manufacturer.

### 9.6 Remote contact

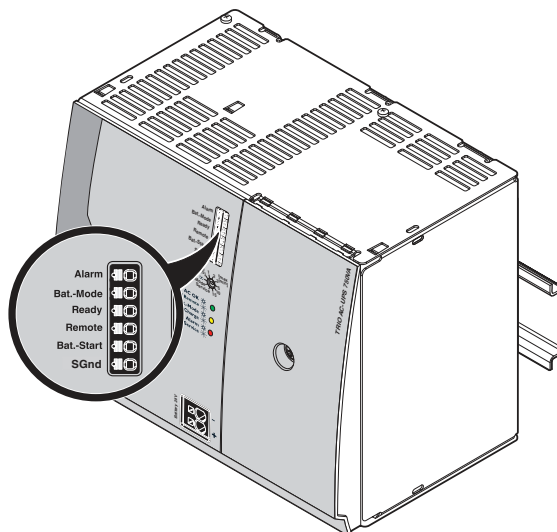

Figure 20 Signal outputs

You can use the Remote signal terminal to:

1. Suppress and exit battery operation.
2. Perform controlled shutdown of the PC in mains operation and battery operation.
3. Perform controlled shutdown of the PC in battery operation.

To perform these steps, you must connect the Remote signal terminal to the SGnd signal terminal.

This sets the UPS internal Remote signal.

### 9.6.1 Suppressing and exiting battery operation

You can switch off the UPS using the function to suppress and exit battery operation.

This function is always active when a buffer time is set.

This function is the default setting in PC mode.

In mains operation, the Remote signal is indicated by the flashing green LED (see Signaling section).

In the event of mains failure, battery operation is not started.

If the Remote signal is generated in battery operation, then battery operation is exited immediately. The UPS output is switched off. This procedure cannot be reversed. The UPS is only activated once the input voltage is applied.

### 9.6.2 Controlled PC shutdown in mains operation and battery operation

You can perform controlled shutdown of the PC in mains operation and battery operation via the UPS-CONF configuration software:

This setting only applies in PC mode.

The Remote signal is indicated by the flashing green LED (see Signaling section).

The PC shuts down, and the delay time under Item 1 is skipped (see PC mode section).

Once the PC has shut down, the UPS output is switched off. When input voltage is present, the connected energy storage devices remain charged and the system is ready to use. When you reset the Remote signal, the UPS output is switched on again.

Once the PC has shut down in battery operation, the UPS output is switched off. This procedure cannot be reversed. The UPS is only activated once the input voltage is applied.

### 9.6.3 Controlled PC shutdown in battery operation

You can perform controlled shutdown of the PC when battery operation is entered via the UPS-CONF configuration software:

This setting only applies in PC mode.

The Remote signal is indicated by the flashing green LED (see Signaling section).

If the Remote signal is generated in mains operation, the PC is shut down when battery operation is entered. The delay time under Item 1 is skipped (see PC mode section).

Once the PC has shut down, the UPS output is switched off.

This procedure cannot be reversed. The UPS is only activated once the input voltage is applied.

### 9.7 Battery start (Bat.-Start)

You can use the Bat.-Start signal terminal to start the UPS without supply voltage on the input side and create an autonomous supply for the load. To do this, you must connect the Bat.-Start signal terminal to the SGnd signal terminal.

The output voltage provided at the load is 230 V/50 Hz.

The maximum duration of the autonomous supply for the load depends on the charging state of the battery.

The signaling corresponds to the signaling for battery operation (see Signaling section).

To exit autonomous operation, you must disconnect the Bat.-Start signal terminal and the SGnd signal terminal.



**WARNING: Danger to life by electric shock!**

In this operating mode, the load connected to the AC output is supplied by the power storage device.

## 10 Signaling

Various LED indicators are available for visual function monitoring of the uninterruptible power supply. Active signal outputs can be used to forward this data to a higher-level control system.

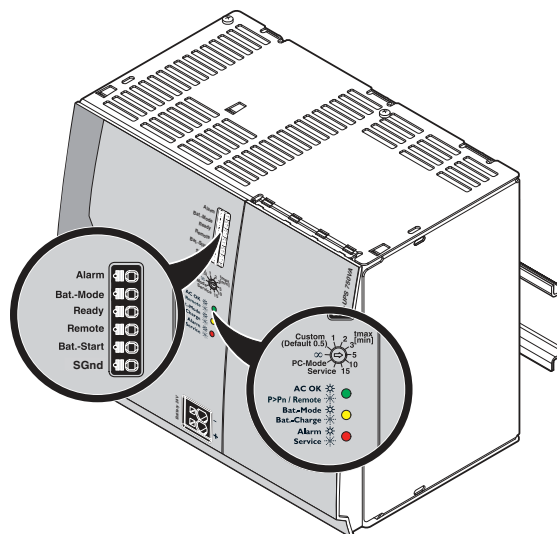

Figure 21 LED indicators and signal outputs

10.1 LED indicators and signal outputs

For UPS signaling and the corresponding states, please refer to the table below.

	Status LED		Switching output			Note
	Green	Yellow	Red	Bat.-Mode	Ready	
			low	low	low	Device off
			low	low	high	Initialization, LED test (~3 sec.)
			low	high	high	Mains operation, battery is fully charged
			low	low or high	high	Mains operation, battery charging in process
			high	low	high	Battery mode
			low	low	low	Mains operation, battery failure
			low	low	low	Mains operation, service mode for battery change
			high	low	low	Battery mode, battery voltage low
			low	high	high	Mains operation, overload (battery mode not possible), battery is fully charged
			high	low	high	Battery mode, overload (only possible for a short time)
			low	low or high	high	Mains operation, overload (battery mode not possible), battery charging in process
			low	low	low	Mains operation, overload (battery mode not possible), battery failure
			low	low	low	Mains operation, overload (battery mode not possible), service mode for battery change
			low	high	high	Mains operation, remote contact shorted to SGnd, battery is fully charged
			low	low or high	high	Mains operation, remote contact shorted to SGnd, battery charging in process
			high	low	high	Battery mode, remote contact shorted to SGnd, (only PC-Mode)
			low	low	low	Mains operation, remote contact shorted to SGnd, battery failure
			low	low	low	Mains operation, remote contact shorted to SGnd, service mode for battery change



Figure 22 Signal states



## 11 Interface

### 11.1 USB interface MINI type B

The uninterruptible power supply is equipped with a USB Mini type B interface for data transmission. A data cable is required for communicating with a PC or a higher-level controller.

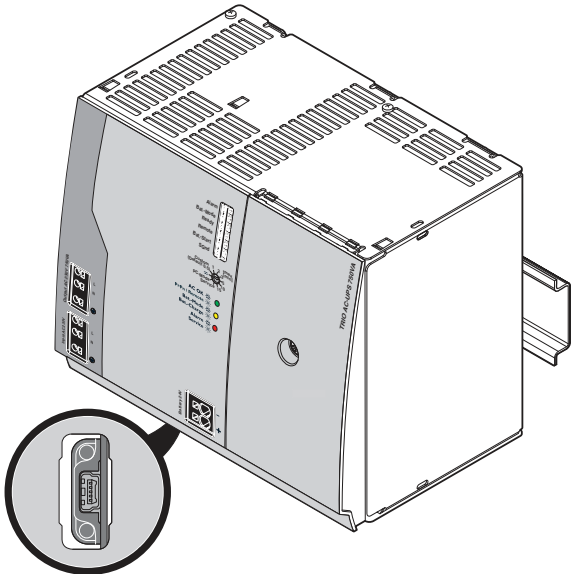

Figure 23 USB interface MINI type B (bottom of device)

#### 11.1.1 MINI-SCREW-USB-DATACABLE

The uninterruptible power supply unit is connected to the USB PC connection with data cable MINI-SCREW-USB-DATACABLE (Order No. 2908217) via USB interface mini type B.

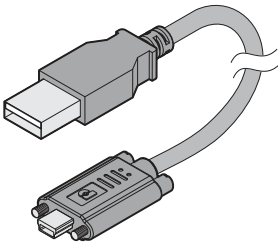

Figure 24 MINI-SCREW-USB-DATACABLE

No.	Designation
1	Mini type B USB connector with screw connection
2	USB plug type A
3	Cable length: 3 m

## 12 Derating

### 12.1 Ambient temperature

In the ambient temperature range, the uninterruptible power supply supplies the nominal power ( $P_N$ ).

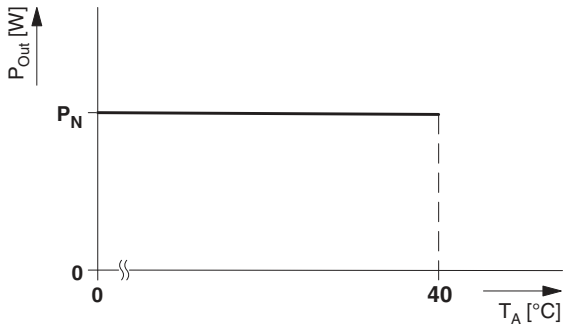

Figure 25 Temperature-dependent derating

### 12.2 Installation height

The uninterruptible power supply can be operated at an installation height of up to 2000 m without any limitations. Different data applies for installation locations above 2000 m due to the differing air pressure and the reduced convection cooling associated with this.

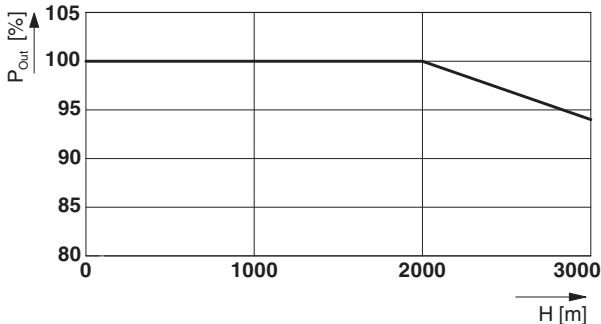

Figure 26 Altitude-dependent derating