

10326-2KM-C

Extreme Networks® 10326-2KM Compatible TAA 40GBase-PLR4 QSFP+ Transceiver (SMF, 1310nm, 2km, MPO, DOM)

Features:

- SFF-8436 Compliance
- MPO Connector
- Single-mode Fiber
- Commercial Temperature 0 to 70 Celsius
- Hot Pluggable
- Metal with Lower EMI
- Excellent ESD Protection
- RoHS Compliant and Lead Free

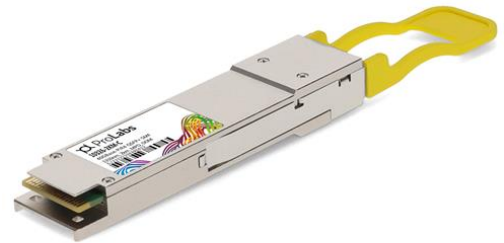

Applications:

- 40GBase Ethernet
- Access and Enterprise

Product Description

This Extreme Networks® 10326-2KM compatible QSFP+ transceiver provides 40GBase-IR4 throughput up to 2km over single-mode fiber (SMF) using a wavelength of 1310nm via an MPO connector. It is guaranteed to be 100% compatible with the equivalent Extreme Networks® transceiver. This easy to install, hot swappable transceiver has been programmed, uniquely serialized and data-traffic and application tested to ensure that it will initialize and perform identically. Digital optical monitoring (DOM) support is also present to allow access to real-time operating parameters. This transceiver is Trade Agreements Act (TAA) compliant. We stand behind the quality of our products and proudly offer a limited lifetime warranty.

ProLabs' transceivers are RoHS compliant and lead-free.

TAA refers to the Trade Agreements Act (19 U.S.C. & 2501-2581), which is intended to foster fair and open international trade. TAA requires that the U.S. Government may acquire only "U.S. – made or designated country end products."



Absolute Maximum Ratings

Parameter	Symbol	Min.	Typ.	Max.	Unit
Supply Voltage	V _{CC}	0		+3.6	V
Storage Temperature	T _{st}	-40		+85	°C
Humidity (non-condensing)	Rh	5		85	%

Recommended Operating Conditions

Parameter	Symbol	Min.	Typ.	Max.	Unit
Power Supply Voltage	V _{CC}	3.13	3.3	3.47	V
Operating Case Temperature	T _{ca}	0	25	+70	°C
Data Rate Per Channel				10.3125	Gbps
Power Supply Voltage	V _{CC}	3.135	3.3	3.465	%
Power Supply Current				2.5	W

Electrical Characteristics

Parameter	Symbol	Min.	Typ.	Max.	Unit	Notes
Transmitter Differential Input Voltage	V _{IN}	180		800	mV _{pp}	
Receiver Differential Output Voltage	V _O	400	450	850	mV _{pp}	1
Loss of Signal (LOS)	V _{CH}	2		V _{CC}	V	2
	V _{OL}	V _{EE}		V _{EE} + 0.8		
Transmitter Disable (TX-Disable)	V _{IH}	2		V _{CC}	V	
	V _{IL}	V _{EE}		V _{EE} + 0.8		
Rx Output Rise and Fall Time	T _r /T _f	28			P _s	20% to 80%

Notes:

1. SFF-8431, SFP+ Module receiver output specifications at C'.
2. LOS is an open collector output. Should be pulled up with 4.7kΩ – 10kΩ on the host board. Normal operation is logic 0; loss of signal is logic 1.

Optical Characteristics

Parameter	Symbol	Unit	Min.	Typ.	Max.	Notes
Transmitter						
Average Launch Power, each lane	P _o	dBm	-8.2		+0.5	
Center wavelength	λ _c	nm	1260		1355	
Optical Spectral Width (RMS)	Δλ	nm			2.5	
Extinction ratio	ER	Db	3.0			
Optical power OMA, each lane	P _{OMA}	dBm	-5.2		+1.5	1
Average launch power of OFF transmitted, each lane	P _{off}	dBm			-30	
RIN ₁₂ OMA	RIN	dB/Hz			-128	
Optical return loss tolerance	ORL _T	dB	12			2
Output eye		Compliant with IEEE802.3ba eye mask				
Receiver						
Center Wavelength	λ _c	nm	1260		1355	
Receiver Overload in OMA, each lane	RxOMA	dBm	+1.5			
Receiver Overload in average power, each lane	P _{max}	dBm	+0.5			3
Average receive power, each lane	RxP _x	dBm	-11.5			4
Receiver Sensitivity in OMA, each lane	Se _{nOMA}	dBm			-9.5	5, for 1.0km type
Receiver Sensitivity in OMA, each lane	Se _{nOMA}	dBm			-10.5	5, for 1.5km type
Receiver Crossing	RCP	%	45		55	
Receiver Eye Mask	SFF-8431, SFP+MODULE RECEIVER OUTPUT SPECIFICATIONS AT 'C'.					
Receiver Eye Mask Margin	REMM	%	0			
Receiver Reflectance	R _{rx}	dB			-12	
LOS	Assert	LOSA	dBm	-30		
	De-assert	LOSD	dBm		-12	
LOS Hysteresis	LOSH	dB	0.5		6	

Notes:

1. Even if the TDP < 1 dB, the OMA (min) must exceed this value.
2. Transmitter reflectance is defined looking into the transmitter
3. The receiver shall be able to tolerate, without damage, continuous exposure to an optical input signal having a power level equal to the average receive power (max) plus at least 1 dB.
4. Average receive power (min) is informative and not the principal indicator of signal strength. A received power below this value cannot be compliant; however, a value above this does not ensure compliance.
5. PRBS 231 -1 at BER 10⁻¹², ER=3.0dB

Digital Diagnostic Memory Map

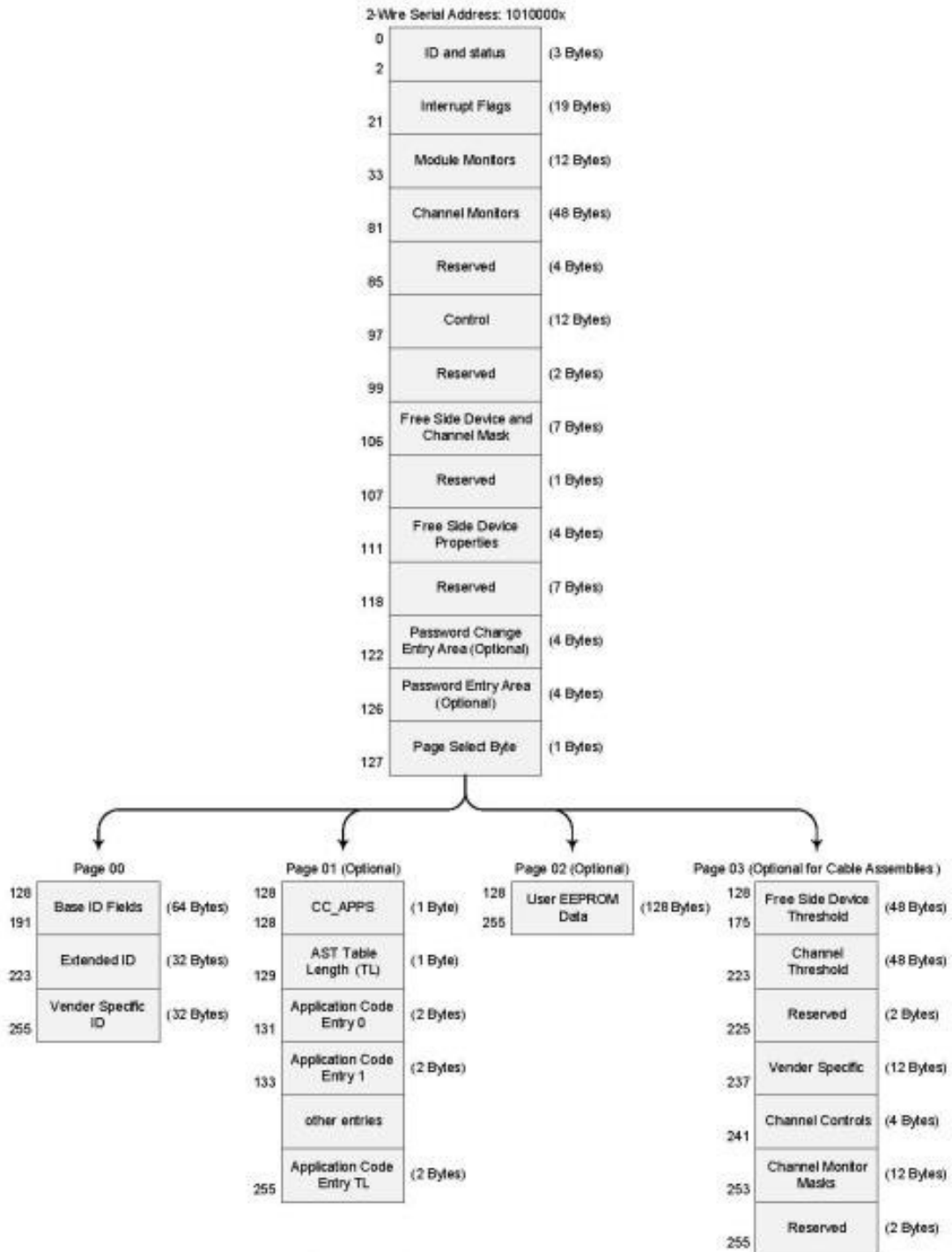

Pin Descriptions

Pin	Logic	Symbol	Name/Descriptions	Ref.
1		GND	Module Ground	1
2	CML-I	Tx2-	Transmitter inverted data input	
3	CML-I	Tx2+	Transmitter non-inverted data input	
4		GND	Module Ground	1
5	CML-I	Tx4-	Transmitter inverted data input	
6	CML-I	Tx4+	Transmitter non-inverted data input	
7		GND	Module Ground	1
8	LVTTTL-I	MODSEIL	Module Select	2
9	LVTTTL-I	ResetL	Module Reset	2
10		VCCRx	+3.3v Receiver Power Supply	
11	LVCNOS-I	SCL	2-wire Serial interface clock	2
12	LVCNOS-I/O	SDA	2-wire Serial interface data	2
13		GND	Module Ground	1
14	CML-O	RX3+	Receiver non-inverted data output	
15	CML-O	RX3-	Receiver inverted data output	
16		GND	Module Ground	1
17	CML-O	RX1+	Receiver non-inverted data output	
18	CML-O	RX1-	Receiver inverted data output	
19		GND	Module Ground	1
20		GND	Module Ground	1
21	CML-O	RX2-	Receiver inverted data output	
22	CML-O	RX2+	Receiver non-inverted data output	
23		GND	Module Ground	1
24	CML-O	RX4-	Receiver inverted data output	
25	CML-O	RX4+	Receiver non-inverted data output	
26		GND	Module Ground	1
27	LVTTTL-O	ModPrsL	Module Present, internal pulled down to GND	
28	LVTTTL-O	IntL	Interrupt output should be pulled up on host board	2
29		VCCTx	+3.3v Transmitter Power Supply	
30		VCC1	+3.3v Power Supply	
31	LVTTTL-I	LPMODE	Low Power Mode	2
32		GND	Module Ground	1
33	CML-I	Tx3+	Transmitter non-inverted data input	
34	CML-I	Tx3-	Transmitter inverted data input	
35		GND	Module Ground	1
36	CML-I	Tx1+	Transmitter non-inverted data input	
37	CML-I	Tx1-	Transmitter inverted data input	
38		GND	Module Ground	1

Notes:

1. GND is the symbol for signal and supply (power) common for QSFP+ modules. All are common within the QSFP+ module and all module voltages are referenced to this potential unless otherwise noted. Connect these directly to the host board signal common ground plane.
2. VccRx, Vcc1 and VccTx are the receiver and transmitter power suppliers and shall be applied concurrently. Recommended host board power supply filtering is shown in the figure below. Vcc Rx, Vcc1 and VccTx may be internally connected within the QSFP+ transceiver module in any combination. The connector pins are each rated for a maximum current of 500mA.

Electrical Pin-out Details

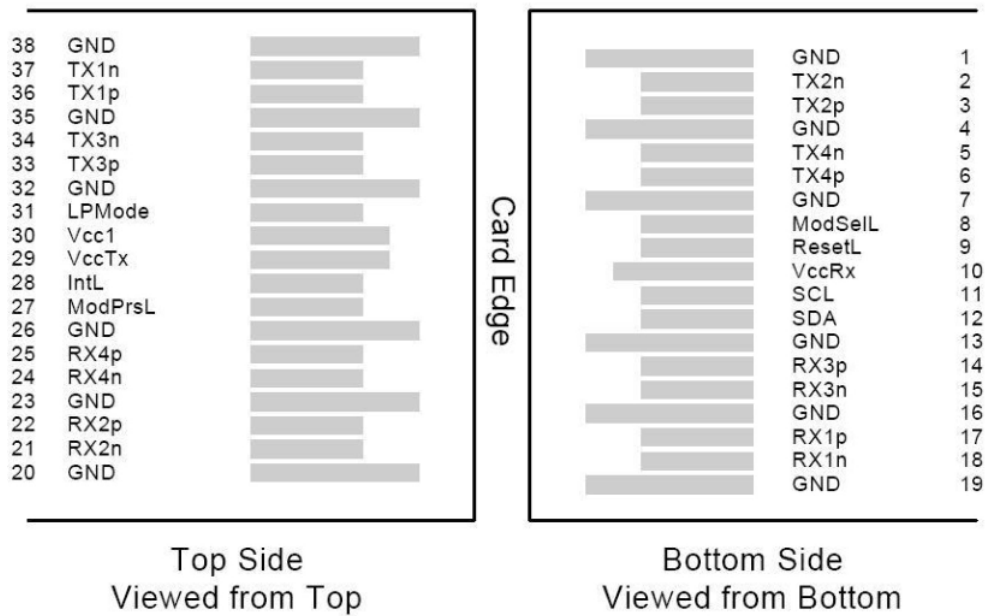

Recommended Power Supply Filter

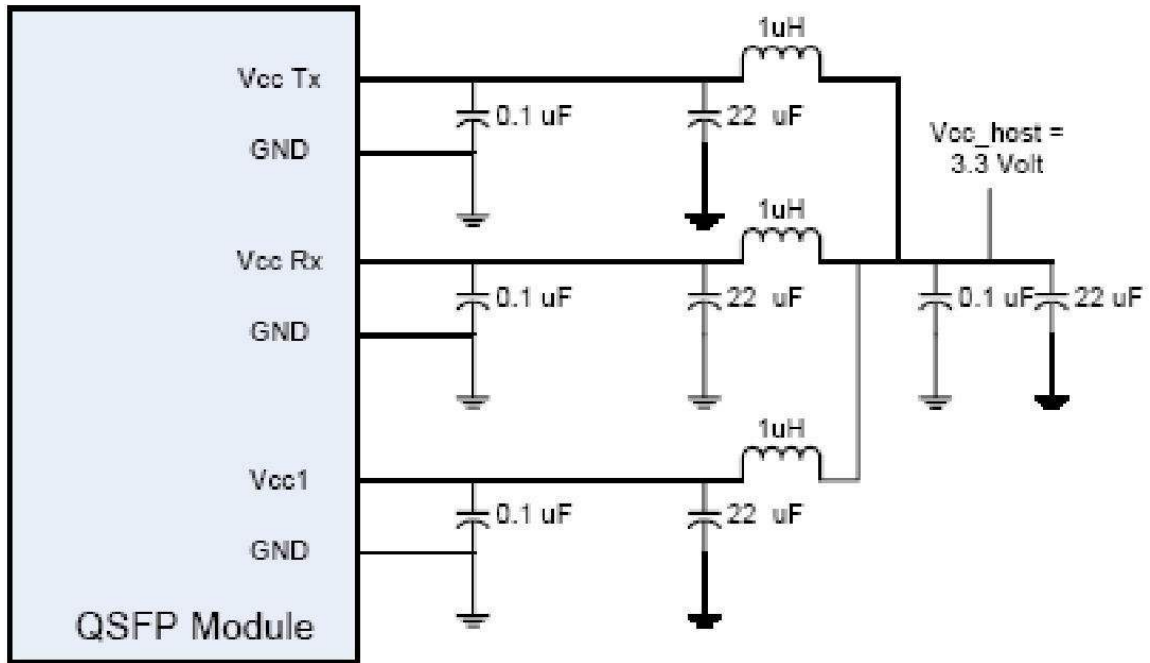

Typical Application Circuit

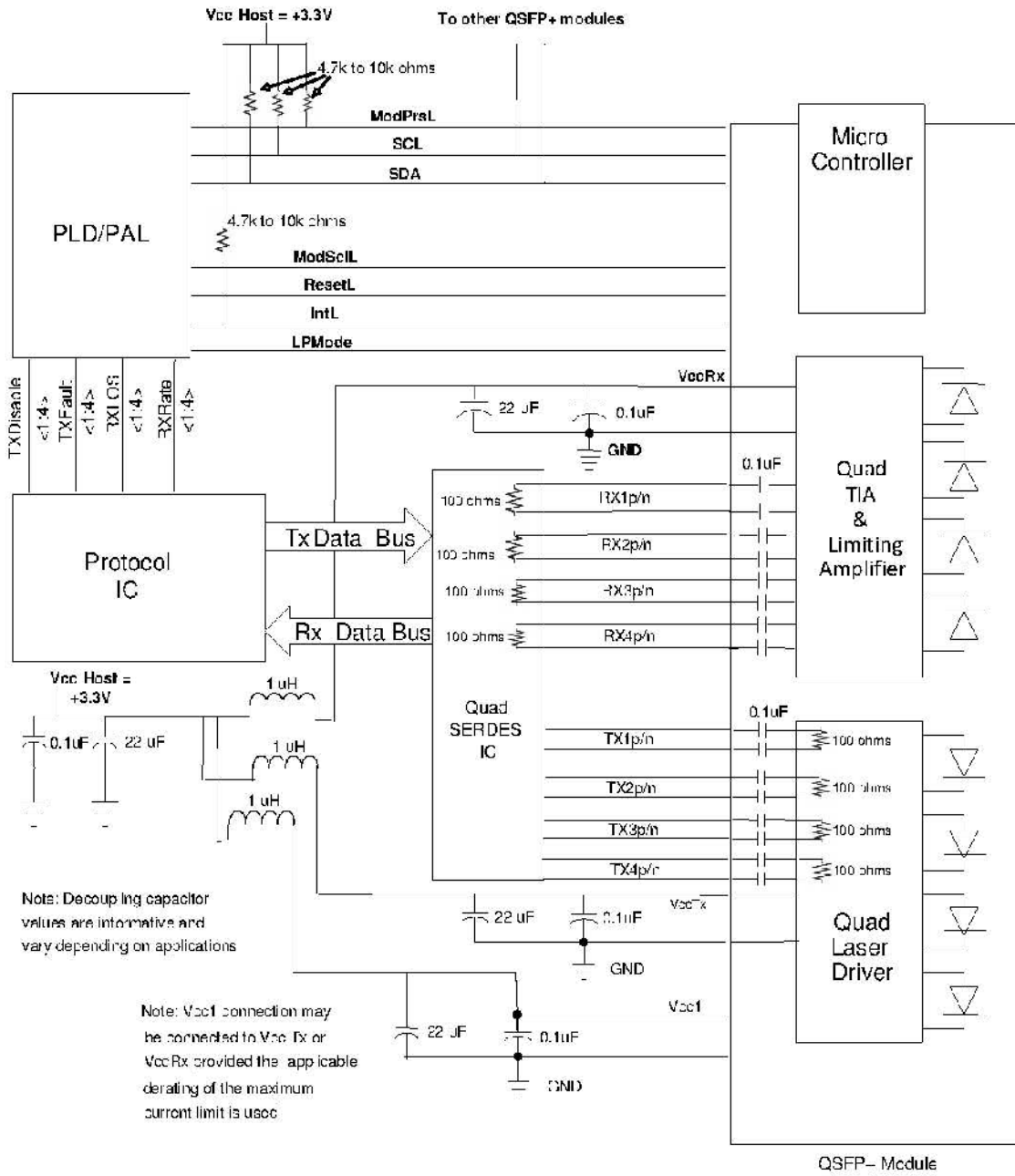

Mechanical Specifications

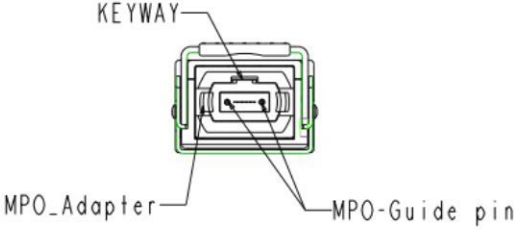
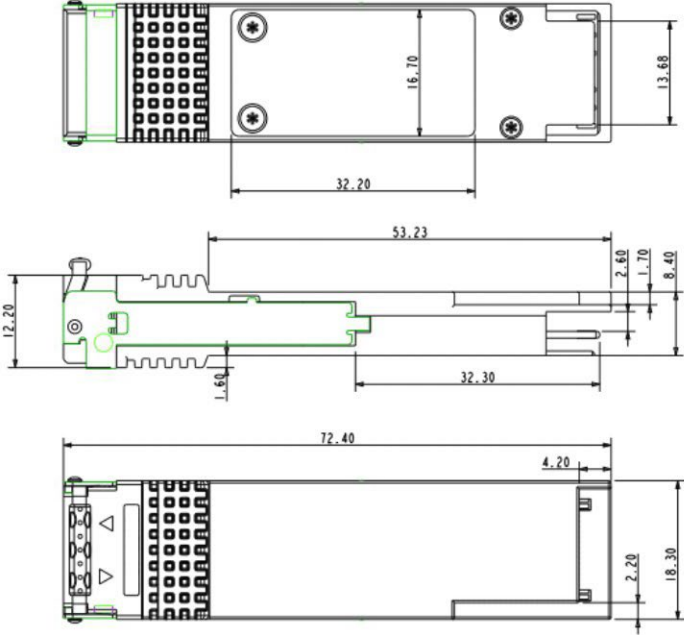

About ProLabs

Our experience comes as standard; for over 15 years ProLabs has delivered optical connectivity solutions that give our customers freedom and choice through our ability to provide seamless interoperability. At the heart of our company is the ability to provide state-of-the-art optical transport and connectivity solutions that are compatible with over 90 optical switching and transport platforms.

Complete Portfolio of Network Solutions

ProLabs is focused on innovations in optical transport and connectivity. The combination of our knowledge of optics and networking equipment enables ProLabs to be your single source for optical transport and connectivity solutions from 100Mb to 400G while providing innovative solutions that increase network efficiency. We provide the optical connectivity expertise that is compatible with and enhances your switching and transport equipment.

Trusted Partner

Customer service is our number one value. ProLabs has invested in people, labs and manufacturing capacity to ensure that you get immediate answers to your questions and compatible product when needed. With Engineering and Manufacturing offices in the U.K. and U.S. augmented by field offices throughout the U.S., U.K. and Asia, ProLabs is able to be our customers best advocate 24 hours a day.



Contact Information

ProLabs US

Email: sales@prolabs.com

Telephone: 952-852-0252

ProLabs UK

Email: salessupport@prolabs.com

Telephone: +44 1285 719 600