

# HVDC CONNECTION

## 380 VDC INPUT / 12 VDC OUTPUT

### HVDC-DC POWER SHELVES

#### SPSPFE3-07, SPSPFE3-12, SPSPFE3-13

SPSPFE3-HVDC power shelf solutions provide rectification, system management, and power distribution, while maintaining high reliability and offering flexibility for future expansion.

The power shelf can be configured with up to six hot-swap capable PFE3000-12-069RA AC/DC-DC power supplies that convert High Voltage DC Bus power into a main output of 12 VDC for powering intermediate bus architectures (IBA) in high performance and reliability servers, routers, and network switches.

The shelf is compatible with the Open Compute Rack Design.

The shelf has an optional slot for Network Attached Controller for providing control functions and monitoring through a 10/100 MB base Ethernet port and can be connected directly to the data center management network.

#### Key Features & Benefits

- Two separate DC inputs, one DC inlet powers 3 power modules.
- Modules are hot-swap capable.
- Modules support I2C communication interface for control, programming and monitoring with Power Management Bus protocol.
- Modules implement the following protections: Overtemperature, output overvoltage and output overcurrent.
- RoHS Compliant.
- Available for OCP V2 bus-bar style connection.

#### Applications

- High Performance Servers
- Routers
- Switches



**bel** POWER SOLUTIONS & PROTECTION

a bel group

[belfuse.com/power-solutions](http://belfuse.com/power-solutions)

### 1. GENERAL BEL POWER SHELF REFERENCE TABLE

		INPUT						
		AC (Y) 277/480 VAC	AC (Y) 240/415 VAC	AC (Δ) 208 VAC	AC (1-Phase) 3x 230 VAC	- 48 VDC	+380 VDC	
OUTPUT	+12 VDC	Triple Busbar Straight	SPSPFE3-05G	SPSPFE3-15*	SPSPFE3-09	-	SPSPFF3-03*	<b>SPSPFE3-13*</b>
		Single Busbar Straight	SPSPFE3-06G	SPSPFE3-16*	SPSPFE3-10	SPSTET4-02	SPSPFF3-02*	<b>SPSPFE3-12*</b>
		Single Busbar Offset <sup>1</sup>	SPSPFE3-08	SPSPFE3-14*	SPSPFE3-11	-	SPSPFF3-01	<b>SPSPFE3-07</b>
	+48 VDC	Single Busbar Offset Short <sup>2</sup>	SPSTET4-01	SPSTET4-11	SPSTET4-03*	-	N/A	SPSTET4-04*
		Single Busbar Offset Long <sup>1</sup>	SPSTET4-07	SPSTET4-12	-	-	N/A	-
		Single Busbar Straight Long	SPSTET4-09	SPSTET4-13	-	-	N/A	-
		Triple Busbar Straight Long	SPSTET4-08	SPSTET4-14	SPSTET4-17*	-	N/A	-
	+380 VDC	Connector Type	SPSTET4-05*	-	SPSTET4-06*	-	-	N/A

<sup>1</sup> Mates with V2

<sup>2</sup> Mates with V2 shallow rack

\* Available on request requiring short design cycle.

**NOTE:** Other datasheets contain alternative shelf configurations, check factory for availability.

### 2. ORDERING INFORMATION

MODEL	INPUT AND OUTPUT CONFIGURATION
SPSPFE3-07	Two 240 to 380 VDC inputs (nominal 380 VDC) 1 set of output blade for +12 VDC output, Offset Bus bar
SPSPFE3-07C	Two 240 to 380 VDC inputs (nominal 380 VDC) 1 set of output blade for +12 VDC output, Offset Bus bar Network Attached Controller included
SPSPFE3-12	Two 240 to 380 VDC inputs (nominal 380 VDC) 1 set of output blade for +12 VDC output, Straight Bus bar
SPSPFE3-12C	Two 240 to 380 VDC inputs (nominal 380 VDC) 1 set of output blade for +12 VDC output, Straight Bus bar Network Attached Controller included
SPSPFE3-13	Two 240 to 380 VDC inputs (nominal 380 VDC) 3 sets of output blades for +12 VDC output (each set of blades has max.585 A)
SPSPFE3-13C	Two 240 to 380 VDC inputs (nominal 380 VDC) 3 sets of output blades for +12 VDC output (each set of blades has max.585 A) Network Attached Controller included

### 3. TECHNICAL DATA

PARAMETER	DESCRIPTION/CONDITION
Input	Two 240 to 380 VDC inputs (nominal 380 VDC)
DC Inlet Configuration	3 power modules are powered from one DC inlet. 2 DC inlets (Input1, Input2)
Redundant Configuration	3+3 or 5+1 configuration
Rated Power 1	8700 W (3+3 configuration) <sup>1</sup>
Rated Power 2	14400 W (5+1 configuration) <sup>1</sup>
Output Connection	SPSPFE3-07: 1 set of output blade for +12 VDC output, Offset Bus bar SPSPFE3-12: 1 set of output blade for +12 VDC output, Straight Bus bar SPSPFE3-13: 3 sets of output blades for +12 VDC output (each set of blades has max.585 A)
Standby Output	60 W (Standby output 12 V / 5 A)
Communication	I <sup>2</sup> C Power Management Bus
NAC2006-01	Network Attached Controller: Ethernet – SNMPv3 / HTTP

### 4. SAFETY WARNING

The user assumes all responsibility and liability for proper and safe handling of the goods. Further, the user indemnifies Bel Power Solutions Inc. from all claims arising from the handling or use of the goods. Persons handling the product(s) must have electronics training and observe good engineering practice standards.

**CAUTION:** Multiple power source. Disconnect all power cords before servicing.

### 5. REFERENCE DOCUMENTS

DOCUMENT NUMBER	DESCRIPTION
BCD.00297	PFE3000-12-069RA Datasheet
BCA.00070	PFE3000-12-069RA Power Management Bus Communication Manual
BCM.00177	Installation Instruction PFE3000-12-069RA
BCD.00926	NAC2006-01 Datasheet
BCA.00178	SPSPFE3-0XG Communication Manual
BCM.00474	Installation Instruction SPSPFE3-07
PCA9547PW	PCA9547PW Datasheet from NXP

### 6. OVERVIEW

The SPSPFE3-HVDC Power Shelf is a 10U height power shelf. It can be configured with up to six hot-swap capable PFE3000-12-069RA AC/DC-DC power supplies that convert High Voltage DC bus mains power into a main output of 12 VDC for powering intermediate bus architectures (IBA) in high performance and reliability servers, routers, and network switches.

The I<sup>2</sup>C communication is routed through an I<sup>2</sup>C Multiplexer (NXP PCA9547PW). PSU Modules support I<sup>2</sup>C communication interface for control, programming and monitoring with the Power Management Bus protocol.

The shelf can be operated by a network attached controller (NAC) for providing monitoring and control functions through a 10/100 MB base Ethernet port and can be connected directly to the data center management network. It is hot-pluggable and supplied via the 12 V standby provided by the power supplies in the shelf. The controller can be configured through a web interface; the monitoring and control functions are accessed through SNMPv3.

<sup>1</sup> Rated Power is reduced as per current share accuracy characteristic. See PFE3000-12-069RA Datasheet.

# HVDC-DC POWER SHELVES SPSPFE3-07, SPSPFE3-12, SPSPFE3-13

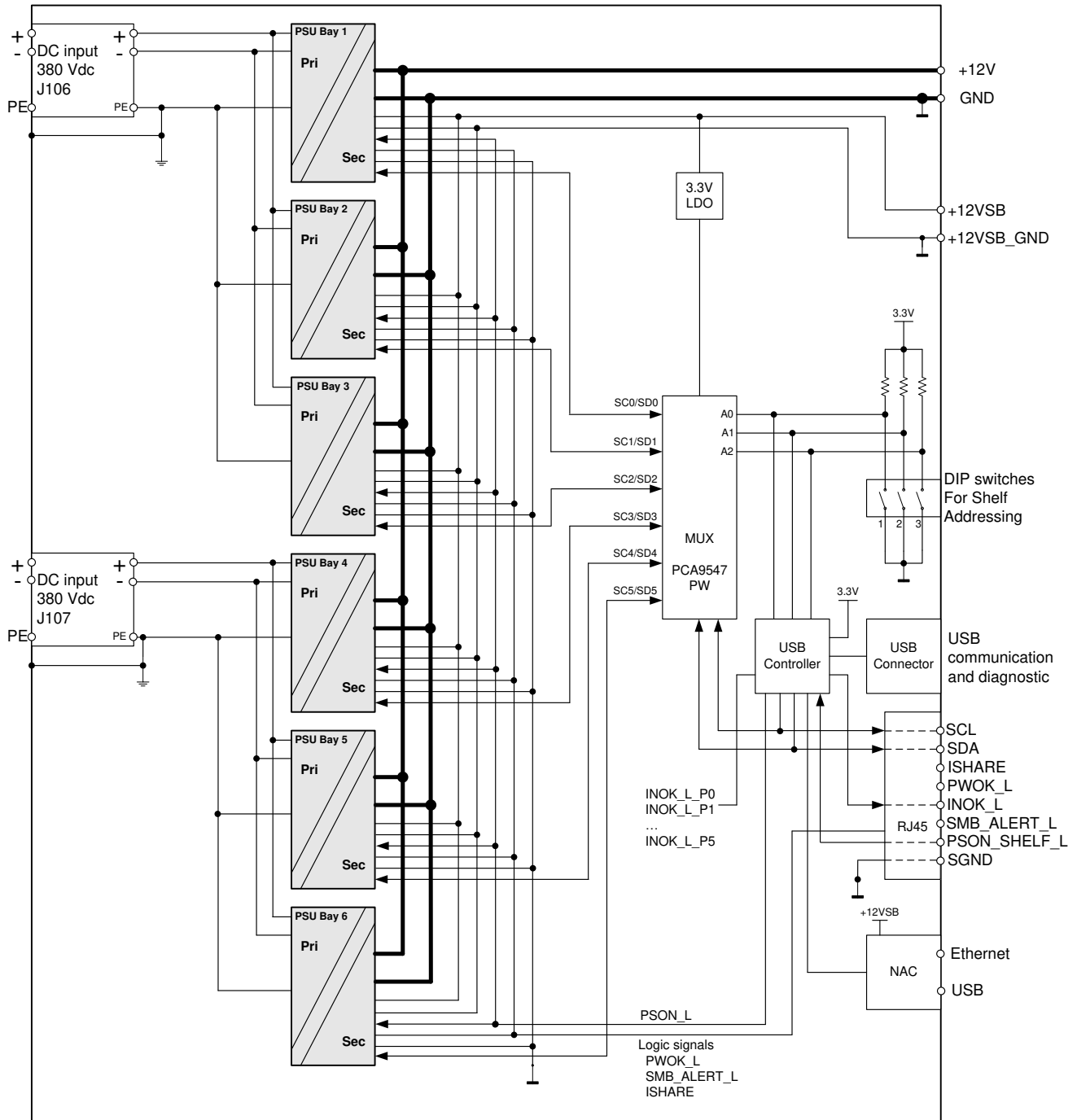

Figure 1. SPSPFE3-HVDC Block Diagram

## 7. INPUT SPECIFICATIONS

PARAMETER	DESCRIPTION / CONDITION	MIN	NOM	MAX	UNIT
<b>Input Connector (J106, J107)</b>					
DC Nominal Input Voltage			380		VDC
DC Nominal Voltage Ranges	Nominal Range	240		380	VDC
DC Input Voltage Ranges	Functional Range	192		400	VDC
Max Input Current	per DC inlets (Input1, Input2)			33	ADC

## 8. OUTPUT SPECIFICATIONS

PARAMETER	DESCRIPTION / CONDITION	MIN	NOM	MAX	UNIT
<b>Main Output V1 (Output Bus Bar)</b>					
Nominal Output Voltage			12.3		VDC
Voltage Regulation		-5		+5	% Vout nom
Nominal Output Power 1	3+3 configuration, $T_a < 45^\circ\text{C}$			8700	W
Derated Output Power 1	3+3 configuration, $T_a = 55^\circ\text{C}^2$			6525	W
Nominal Output Power 2	5+1 configuration, $T_a < 45^\circ\text{C}$			14400	W
Derated Output Power 2	5+1 configuration, $T_a = 55^\circ\text{C}^3$			10800	W
Nominal Output Current 1	3+3 configuration, $T_a < 45^\circ\text{C}$			707	ADC
Derated Output Current 1	3+3 configuration, $T_a = 55^\circ\text{C}^3$			530	ADC
Nominal Output Current 2	5+1 configuration, $T_a < 45^\circ\text{C}$			1171	ADC
Derated Output Current 2	5+1 configuration, $T_a = 55^\circ\text{C}^3$			878	ADC
<b>Standby Output VSB (J23)</b>					
Output Voltage			12		VDC
Voltage Regulation		-5		+5	% Vout nom
Output Power				60	W
Output Current				5	ADC

<sup>2</sup> Linear derating at  $T_a > 45^\circ\text{C}$  is based per module, see PFE3000-12-069RA datasheet

## 7.1 PROTECTION (PER MODULE)

PARAMETER	DESCRIPTION / CONDITION	MIN	NOM	MAX	UNIT
Input Fuses (L+N)	Not user accessible, quick-acting (F)		25		A
OV Threshold $V_I$		13.6	14.2	14.8	VDC
OV Latch Off Time $V_I$				1	ms
OV Threshold $V_{SB}$		13.3	13.9	14.5	VDC
OV Latch Off Time $V_{SB}$				1	ms
Current Limitation	$T_a < 45^\circ\text{C}$ $T_a = 55^\circ\text{C}$	248 186		274 212	A
Current Limit Blanking Time	Time to latch off when in over current	20	22	24	ms
Current Limit During Short Time Overload $V_I$	Maximum duration 20ms, per module	292	300	308	A
Max Short Circuit Current $V_I$	$V_I < 3\text{ V}$ , per module			350 <sup>3</sup>	A
Short Circuit Latch Off Time	Time to latch off when in short circuit		10		ms
Current Limitation $V_{SB}$	Per module	6		9	A
Current Limit Blanking Time	Time to hit hiccup when in over current			1	ms
Over Temperature on Critical Points	Inlet Ambient Temperature PFC Primary Heatsink Temperature Secondary Sync Mosfet Temperature Secondary OR-ing Mosfet Temperature			60 80 115 125	$^\circ\text{C}$

## 7.2 INTERFACE & CONTROL SIGNALS

The PWOK\_L is an open collector output of all modules and they are interconnected (wired-OR) within the shelf and this signal is fed to the signal connector. PWOK\_L is low when there is at least one module in operation. SMB\_ALERT\_L is also wired-OR already in the shelf. Sink current must not exceed 4 mA on each of these signals.

The internal INOK\_L\_Px signal of each individual module is fed to the backplane microcontroller for modules synchronized DC startup. This allows the shelf to start up with load > 3000 W during HVDC application. The microcontroller provides an INOK\_L output signal. INOK\_L is low when there is at least one module supplied with correct input voltage.

PSON\_SHELF\_L signal is an internally pulled-up input signal (3.3 V) to enable / disable the main output V1 of the Shelf. This active-low pin is also used to clear any latched fault condition. This is similar to the PSON\_L on the PSU level. PSON\_SHELF\_L is currently bypassed in ON\_OFF\_CONFIG command. A pull up resistor of 10k $\Omega$  to 3.3 V within the shelf provides the high level voltage for the PWOK\_L, INOK\_L and SMB\_ALERT\_L signals.

The Power Shelf V1 output is capable to be operated in redundant mode by interconnecting the ISHARE on J20.

Please consult BPS Technical Representative for details.

RJ45 PIN OUTS (J20)	FUNCTION	DESCRIPTION
1 <sup>4</sup>	SCL	I2C clock signal line
2 <sup>5</sup>	SDA	I2C data signal line
3	ISHARE	V1 Current share bus
4	PWOK_L	Power OK signal output: active-low
5	INOK_L	Input OK signal: active-low
6	SMB_ALERT_L	SMB Alert signal output: active-low
7	PSON_SHELF_L	Power Shelf on input: active-low
8	SGND	Signal ground

Table 1. I2C Interface and Signal Connector (RJ45) Pin Out

<sup>3</sup> Limit doesn't include effects of main output capacitive discharge

<sup>4</sup> External Pull-up resistor should be 2 – 5k $\Omega$  to ensure SMBUS compliant signal rise times

### 7.3 I2C COMMUNICATION

The PSU Modules are set to a fixed I2C Address (0x20). Power Management Bus communication for the PSU Modules are described in more detail in document BCA.00070. The I2C communication to the PSU Modules are routed through an I2C Multiplexer. The I2C MUX Control Register needs to be configured so that the I2C frames are routed to the correct PSU Module. Refer to the I2C MUX datasheet for additional information.

The I2C MUX and backplane controller addresses are configurable via DIP Switches (SW1);

The PSON function of the shelf can also be controlled by a Power Management Bus command sent to the backplane Controller, see document BCA.00178 for further information and the table below.

COMMAND		ACCESS	DATA BYTES	COMMENTS
Code	Name			
0x01	OPERATION	Byte R/W	1	Supported Values: 0x00 = Unit Off 0x80 = Unit On (Default)
0x02	ON_OFF_CONFIG	Byte R/W	1	Supported Values: 0x19 (Default) 0x01, 0x11, 0x15, 0x1D

**NOTE:** A setting in the ON\_OFF\_CONFIGURATION register doesn't survive a power cycle. See also the Power Management Bus protocol definition.

### 7.4 I2C ADDRESSING (SHELF)

The shelf default MUX address is 0xEE and Controller address is 0x5E. When DIP switch (SW1) is in "ON" position means 0, "OFF" Position means 1.

POSITION 1	POSITION 2	POSITION 3	MUX ADDRESS (IN HEX)	Controller ADDRESS (IN HEX)
ON	ON	ON	0xE0	0x50
OFF	ON	ON	0xE2	0x52
ON	OFF	ON	0xE4	0x54
OFF	OFF	ON	0xE6	0x56
ON	ON	OFF	0xE8	0x58
OFF	ON	OFF	0xEA	0x5A
ON	OFF	OFF	0xEC	0x5C
OFF	OFF	OFF	0xEE	0x5E

**NOTE:** Communication Manual of shelf, see document BCA.00178.

Table 2. DIP Switch Setting (SW1)

### 7.5 NETWORK ATTACHED CONTROLLER

The Network Attached Controller (NAC2006-01) is a shelf level controller providing monitoring and control functions through a 10/100 MB base Ethernet port and can be connected directly to the data center management network. It is hot-pluggable and supplied via the 12 V redundant standby provided by the power supplies in the shelf. The controller can be configured through a web interface; the monitoring and control functions are accessed through SNMP.

See BCD.00926 for NAC2006-01 Datasheet.

## 7.6 CONTROL LEDs

Each PSU front-end module has 2 LEDs to indicate status condition. LED number one is green and indicates DC power is on or off, while LED number two is bi-colored: green and yellow and indicates DC power presence or fault situations.

PARAMETER	DESCRIPTION / CONDITION	LED SIGNALING
<b>AC LED</b>	DC Line within range	Solid Green
	DC Line UV condition	Off
	Normal Operation	Solid Green
	PSON_L High	Blinking Yellow (1:1)
<b>DC LED<sup>5</sup></b>	$V_I$ or $V_{SB}$ out of regulation	Solid Yellow
	Over temperature shutdown	
	Output over voltage shutdown ( $V_I$ or $V_{SB}$ )	
	Output under voltage shutdown ( $V_I$ or $V_{SB}$ )	Blinking Yellow/Green (2:1)
	Output over current shutdown ( $V_I$ or $V_{SB}$ )	
	Over temperature warning	
	Minor fan regulation error (>5%, <15%)	

## 7.7 USB CONNECTOR TYPE B (J3)

This is used for Bel Power Diagnostic thru Bel Power Solutions I<sup>2</sup>C Utility GUI. This connection also provides access to FW boot loading of the PSU Modules.

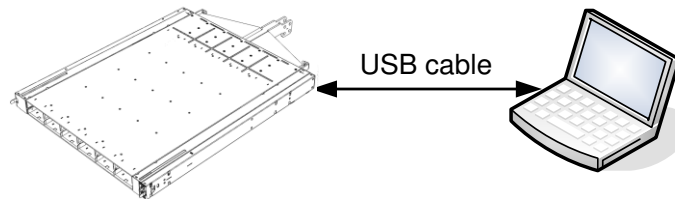

Figure 2. Connection

### WARNING:



The USB interface is NOT galvanically isolated and referenced to the +12V\_GND / SGND lines. Preferably, use a battery operated laptop to avoid earth loop issues. If a desktop computer is being used, there is a risk of generating earth loop currents, therefore the usage of a USB isolator is highly recommended in such a case.

## 7.8 +12VSB CONNECTOR (J23)

+12VSB output is capable of delivering 5A. The output is protected by a PTC (16R900GF from Littelfuse).  
Mating Part: Molex 39-01-2045

PIN OUTS (J23)	FUNCTION	DESCRIPTION
1, 3	VSB_GND	+12VSB return
2, 4	VSB	+12VSB output

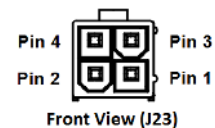

<sup>5</sup> The order of the criteria in the table corresponds to the testing precedence in the controller.



## 9. SAFETY, REGULATORY AND EMC SPECIFICATIONS

PARAMETER	DESCRIPTION / CONDITION	CRITERION
Agency Approvals	UL / CSA 60950-1 IEC / EN 60950-1	Approved
	UL / CSA 62368-1 IEC / EN 62368-1	Approval pending
Insulation	Input (DCIN+ / DCIN-) to case (PE) Input (DCIN+ / DCIN-) to output Output to case (PE)	Basic Reinforced Functional
Creepage / Clearance ( <i>dc</i> )	Input (DCIN+ / DCIN-) to protective earth (PE) Primary to secondary	
Electrical Strength Test	Input to case Input to output (tested by manufacturer only)	Min. 2121 VDC Min. 4242 VDC
Conducted Emission	EN55022 / CISPR 22: 0.15 ... 30 MHz, QP and AVG	Class A
Radiated Emission	EN55022 / CISPR 22: 30 MHz ... 1 GHz, QP	Class A
Harmonic Emissions (per module)	IEC61000-3-2, $V_{in}$ = TBD VDC, 100% Load (per module)	TBD
Acoustical Noise	Sound power statistical declaration (ISO 9296, ISO 7779, IS9295) @ 50% load	60 dBA
ESD Contact Discharge	IEC / EN 61000-4-2, $\pm 8$ kV, 25+25 discharges per test point (metallic case, LEDs, connector body)	A
ESD Air Discharge	IEC / EN 61000-4-2, $\pm 15$ kV, 25+25 discharges per test point (non-metallic user accessible surfaces)	A
Radiated Electromagnetic Field	IEC / EN 61000-4-3, 10 V/m, 1 kHz/80% Amplitude Modulation, 1 $\mu$ s Pulse Modulation, 10 kHz...2 GHz	A
Burst	IEC / EN 61000-4-4, level 3 AC port $\pm 2$ kV, 1 minute DC port $\pm 1$ kV, 1 minute	A
Surge	IEC / EN 61000-4-5 Line to earth: level 3, $\pm 2$ kV Line to line: level 2, $\pm 1$ kV	A
RF Conducted Immunity	IEC/EN 61000-4-6, Level 3, 10 Vrms, CW, 0.1 ... 80 MHz	A
Voltage Dips and Interruptions (per module)	IEC/EN 61000-4-11 (per module)	TBD

## 10. ENVIRONMENTAL SPECIFICATIONS

PARAMETER	DESCRIPTION / CONDITION	MIN	NOM	MAX	UNIT
Operating Temperature	@ full load, up to 4000 m:	0		+35	°C
	@ full load, up to 1800 m:	0		+45	
	@ 75% load, up to 1800 m:	0		+55	
Non-Operating Temperature		-40		+70	°C
Humidity	Operating: @ at 40 °C, non-condensing	7		93	%RH
	Non-Operating: non-condensing	5		95	
Altitude	Operating:			4000	m
	Non-Operating:			13000	
Shock	Operating: 11 ms half-sine shocks in Z axis 10+ve, 10-ve		5		g
	Non-Operating: 11 ms half-sine shocks in Z axis 10+ve, 10-ve		30		
Vibration	Operating: 0.2 $g_{rms}$ random	5		500	Hz
	Non-Operating: 1 $g_{rms}$ random	2		200	
Acoustic Noise Emissions	@ normal operation, and 50% load sharing			70	dBA
	Fan speed			7000	
Cooling	When equipped with operating PSUs			50	Pa

## 11. MECHANICAL SPECIFICATIONS



Asia-Pacific  
+86 755 298 85888

Europe, Middle East  
+353 61 225 977

North America  
+1 408 785 5200

PARAMETER	SPSPFE3-HVDC
Dimensions (W x H x D)	534.5 x 46.5x 650 mm (overall: 535 x 47 x 859.5 mm)
Weight (Shelf only)	16 kg
Weight (6 PSU installed)	32 kg

## 10.1 CONNECTORS

### 10.1.1 Input

DESCRIPTION	REFERENCE DESIGNATOR	TYPE	MANUFACTURER	MPN	MATING PART MPN
Input Connector	J106, J107	HVDC Input	ANDERSON POWER PRODUCTS	SBS75XPRBLK-BK	SBS75XBLK-BK
Protective Earth		2x M6 PEM <sup>6</sup>			

### 10.1.2 Output

DESCRIPTION	REFERENCE DESIGNATOR	TYPE	MANUFACTURER	MPN	MATING PART MPN
USB I2C Connector	J3	USB – B type	Tyco	292304-1	
I2C Interface and Signal Connector	J20	RJ45	FCI Connectors	87180-088LF	
+12VSB output connector	J23		Molex	39-30-0040	39-01-2045

<sup>6</sup> Mating M6 Screw + Washer are delivered together with the shelf

SHELF

HIGH VOLTAGE CONNECTOR PIN ASSIGNMENT

HVDC Input Connector  
(J106, J107)

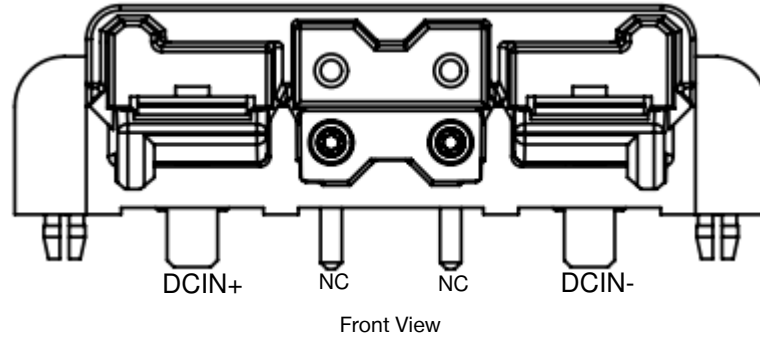

MPN                      SBS75XPRBLK-BK  
Mating Part            SBS75XBLK-BK

Protective Earth Chassis

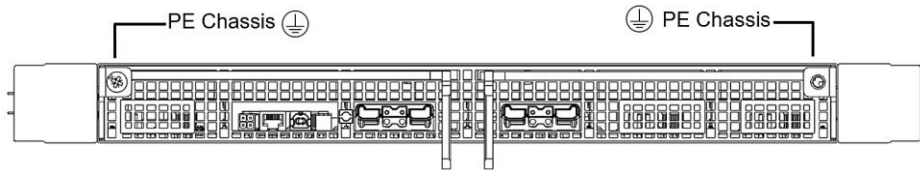

2x M6 PEM

10.2 SPSPFE3-HVDC MECHANICAL DATA:

**NOTE:** finished good may look different from images.

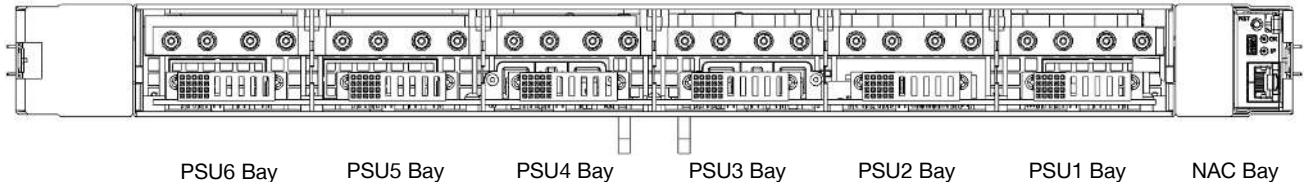

Figure 3. SPSPFE3-07 Front View

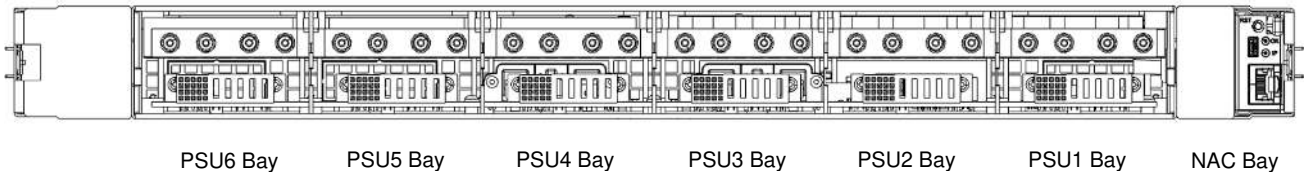

Figure 4. SPSPFE3-12 and SPSPFE3-13 Front View

# HVDC-DC POWER SHELVES SPSPFE3-07, SPSPFE3-12, SPSPFE3-13

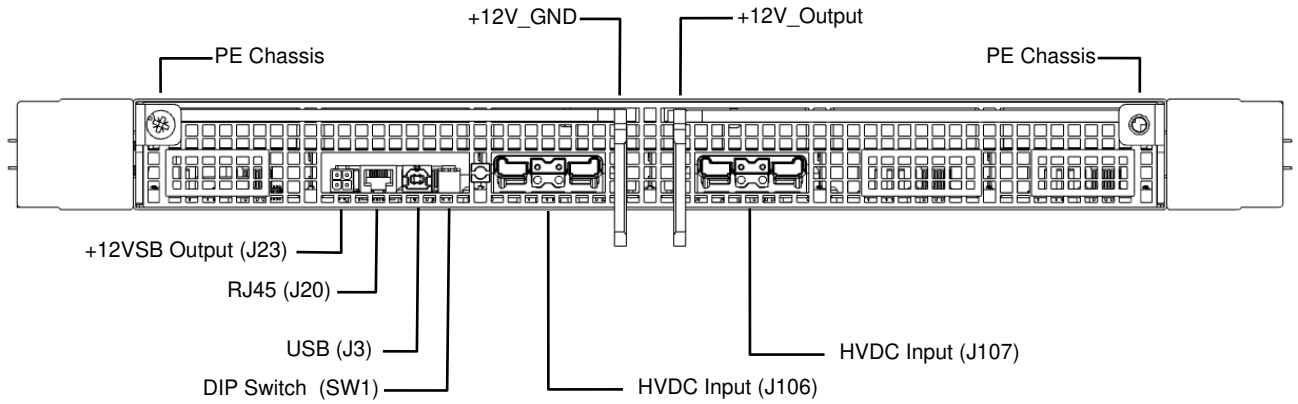

Figure 5. SPSPFE3-07 Rear View

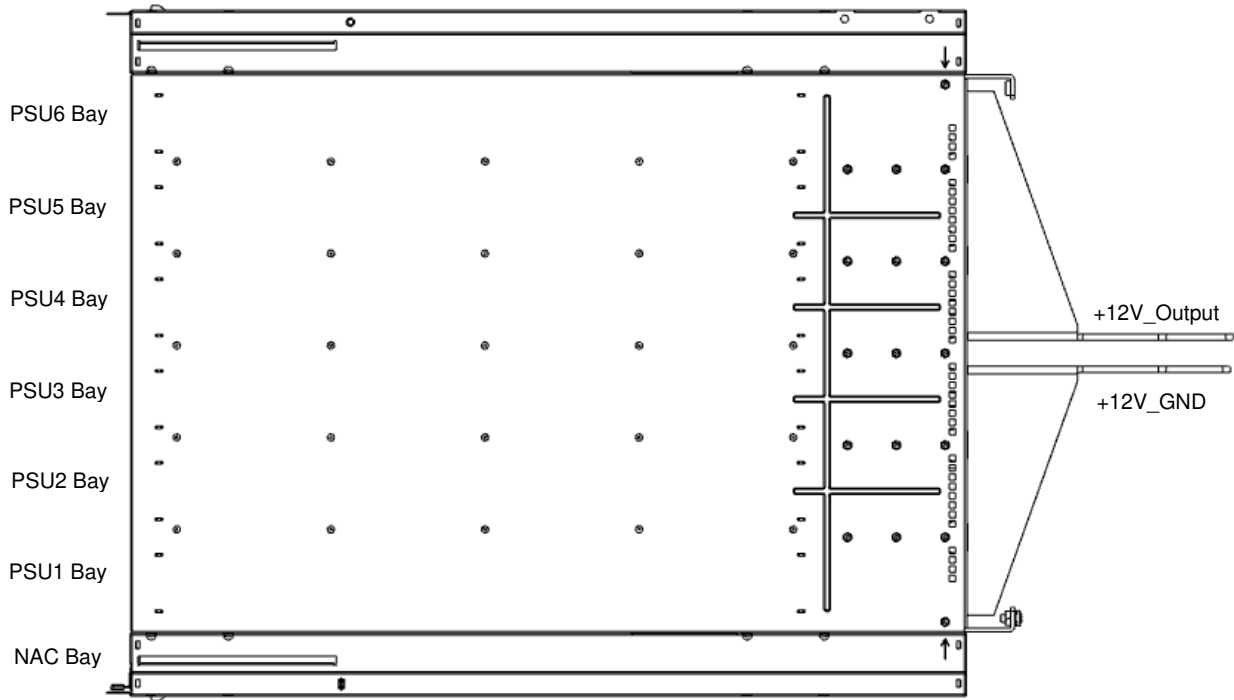

Figure 6. SPSPFE3-07 Top View

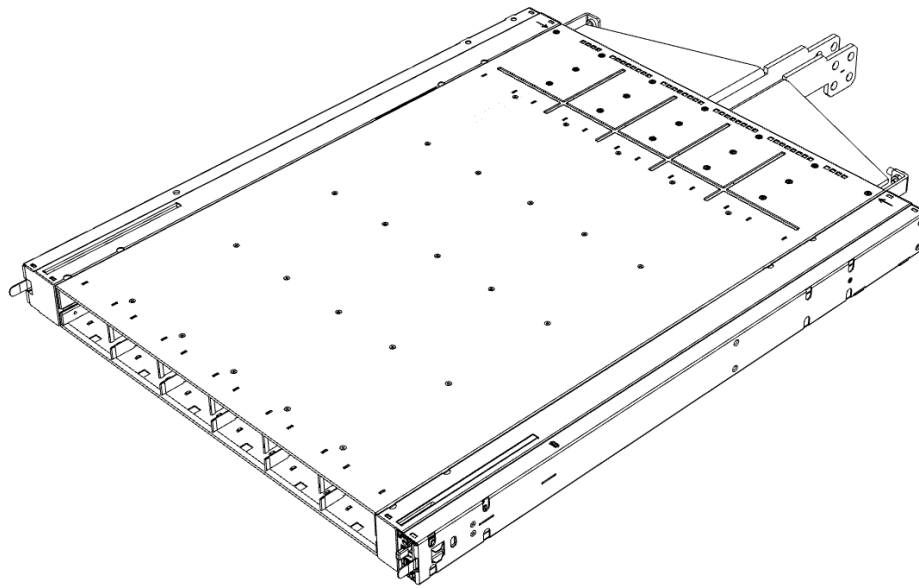

Figure 7. SPSPFE3-07 Isometric View

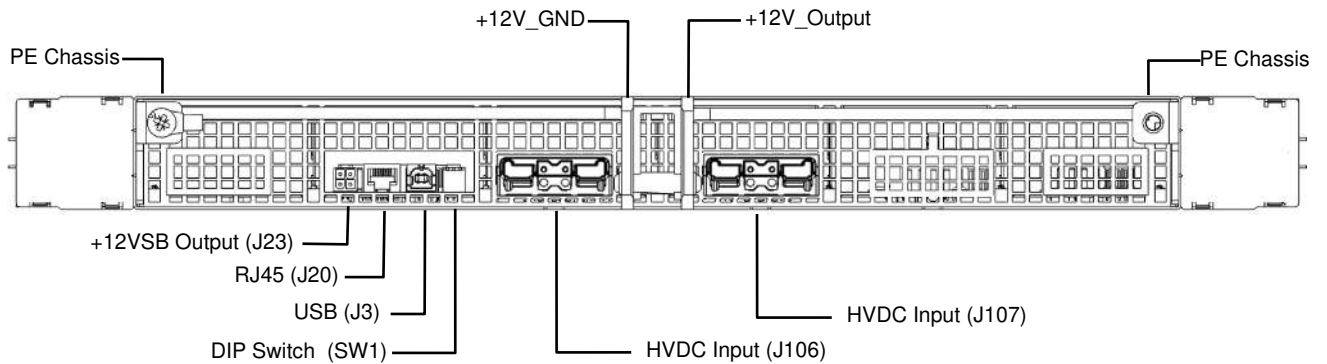

Figure 8. SPSPFE3-12 Rear View

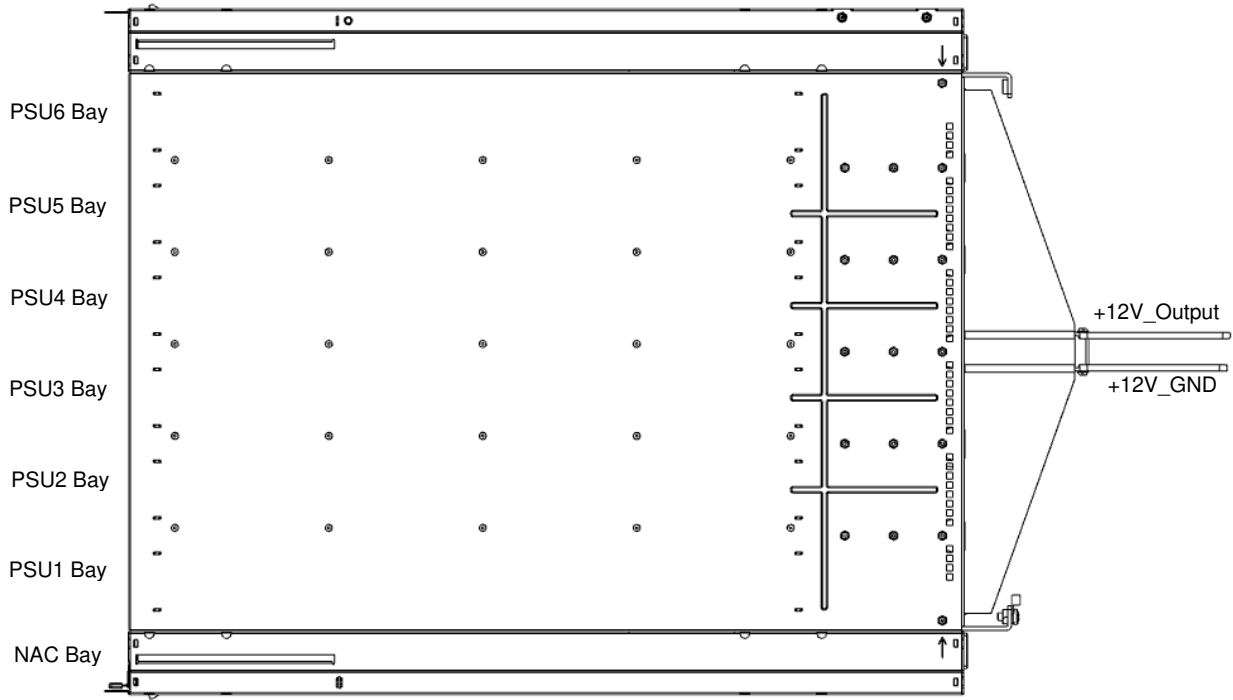

Figure 9. SPSPFE3-12 Top View

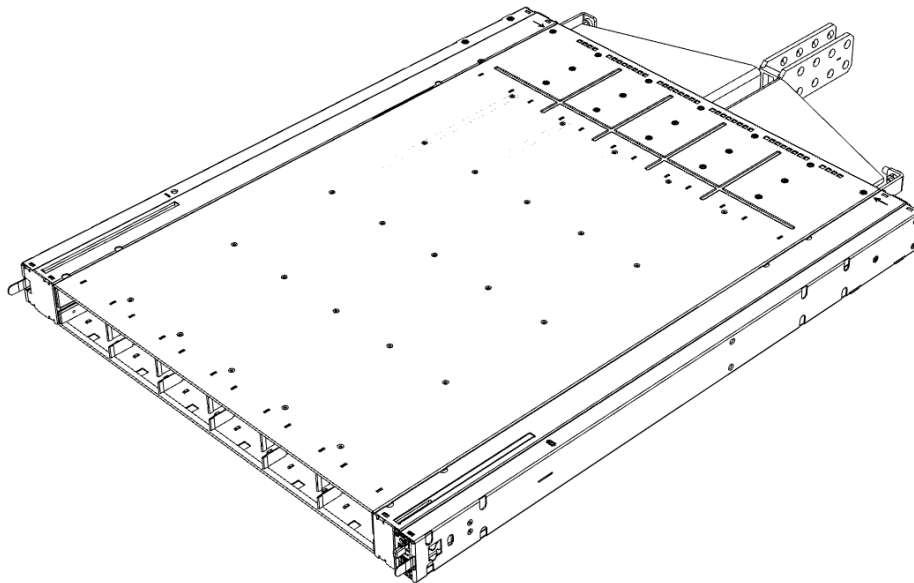

Figure 10. SPSPFE3-12 Isometric View

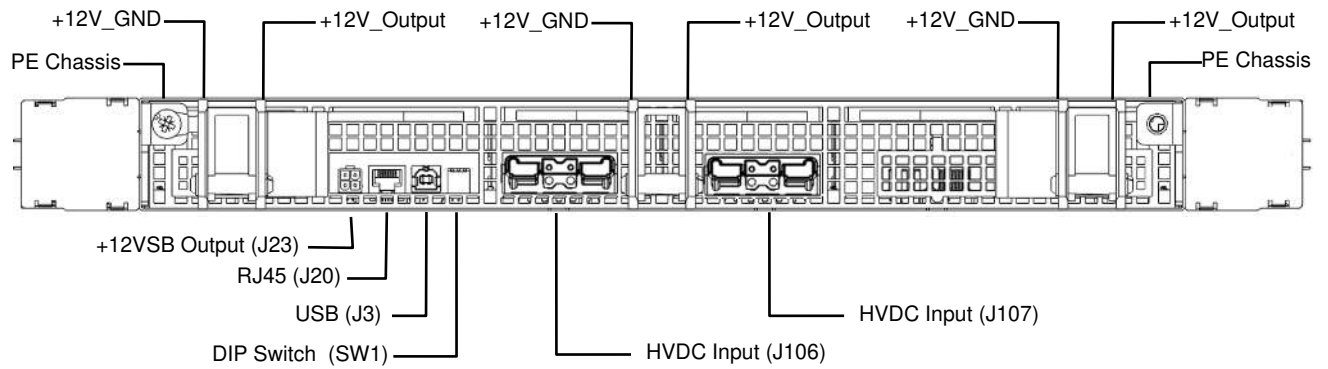

Figure 11. SPSPFE3-13 Rear View

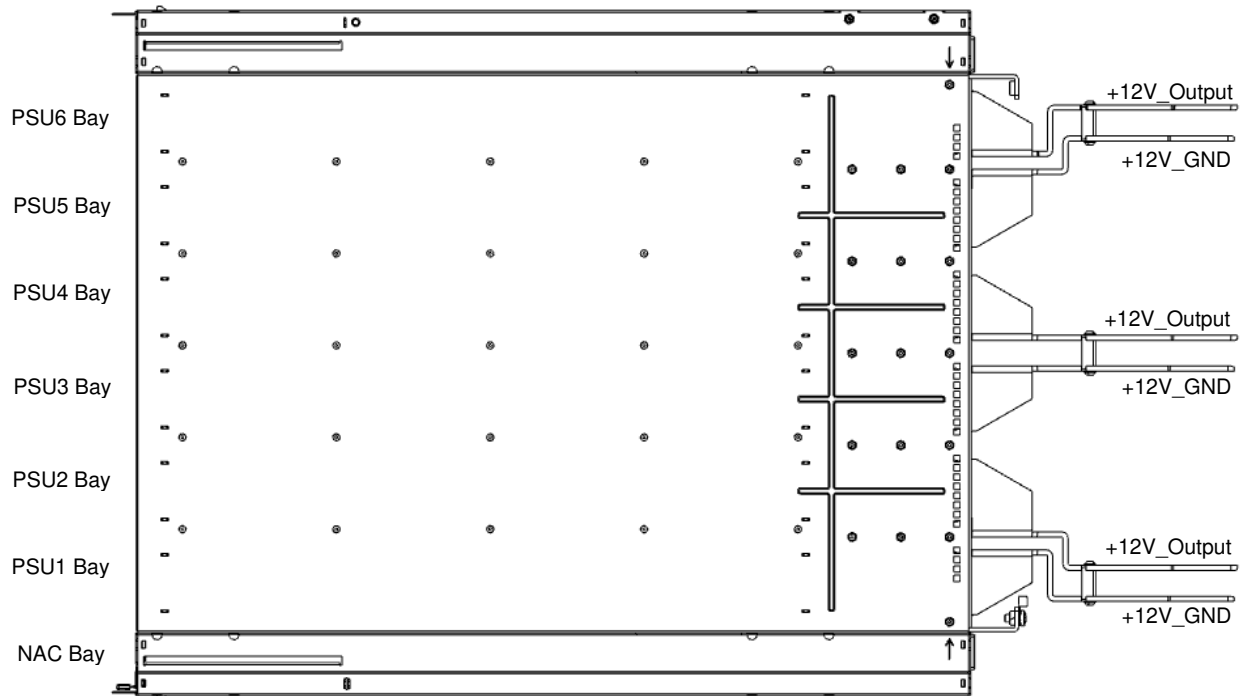

Figure 12. SPSPFE3-13 Top View

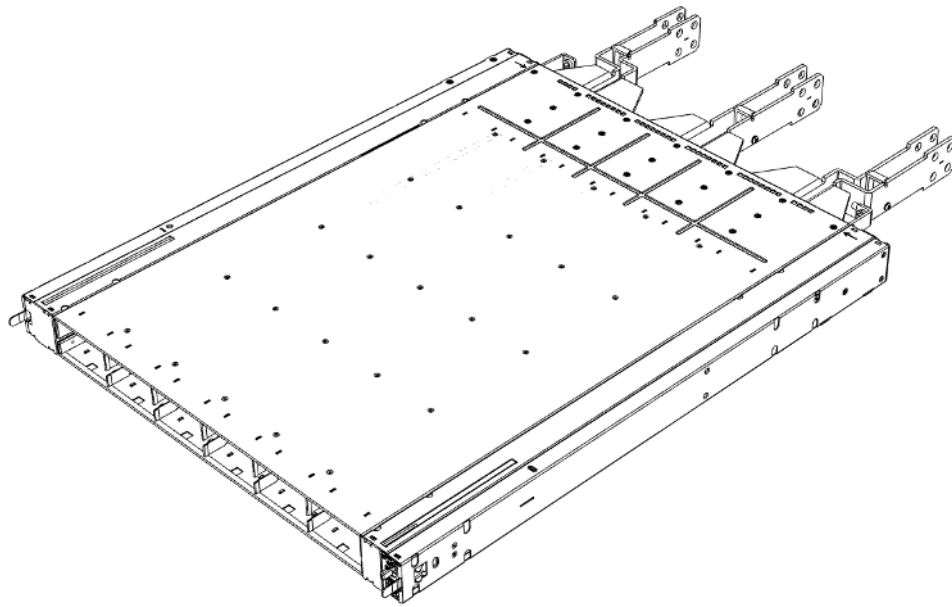

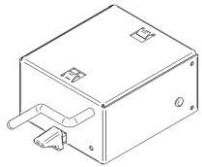

Figure 13. SPSPFE3-13 Isometric View

12. ACCESSORIES

ITEM	DESCRIPTION	ORDERING PN	SOURCE
	<p>I<sup>2</sup>C Utility Windows Vista/7/8 compatible GUI to program, control and monitor PFE Front-Ends (and other I<sup>2</sup>C units)</p>	<p>N/A</p>	<p><a href="http://belfuse.com/power-solutions">belfuse.com/power-solutions</a></p>
	<p>Blanking Panel</p>	<p>SPSPFE3-BP01G</p>	<p><a href="http://belfuse.com/power-solutions">belfuse.com/power-solutions</a></p>



### 13. REVISION HISTORY

REV	DESCRIPTION	PRODUCT VERSION	DATE	AUTHOR
001	PRELIMINARY: Initial Draft	V001	08-31-2017	GS
002	Update Mechanical View	V001	10-05-2017	GS
003	DC input voltage align with PSU Module.	V001	10.31.2017	GS
004	Update Datasheet part number for NAC2006-01. PMBus™ changed to Power Management Bus; a disclaimer added to the first page	V001	02-28-2018	VS
005	Network Attached Controller is set to optional. Update Ordering Information. Removed Pending on Safety Agency Approvals	V002	04-24-2018	GS
006	Disclaimer on the first was removed Power Management Bus needs to be fully spelled out every time it is used with no trademark symbols used	V003	04-26-2019	VS
007	Enable Current Share Function of Shelf Pin 3 of Connector J20 used for ISHARE signal Add SPSPFE3-12 and SPSPFE3-13 Models	V003	09-30-2019	GS
A	Release to A revision		04-29-2021	

**For more information on these products consult: [tech.support@psbel.com](mailto:tech.support@psbel.com)**

**NUCLEAR AND MEDICAL APPLICATIONS** - Products are not designed or intended for use as critical components in life support systems, equipment used in hazardous environments, or nuclear control systems.

**TECHNICAL REVISIONS** - The appearance of products, including safety agency certifications pictured on labels, may change depending on the date manufactured. Specifications are subject to change without notice.



Asia-Pacific  
 +86 755 298 85888

Europe, Middle East  
 +353 61 225 977

North America  
 +1 408 785 5200