

## Introduction

The evaluation board is designed to help the customer evaluate the 5P1105/5P1103, the latest additions to the family of programmable devices in IDT's Timing portfolio. When the board is connected to a PC running IDT Timing Commander™ Software through USB, the device can be configured and programmed to generate frequencies with best-in-class performances.

## Board Overview

Use the following diagram to identify: power supply jacks, USB connector, input and output frequency SMA connectors.

Figure 1. Board Overview

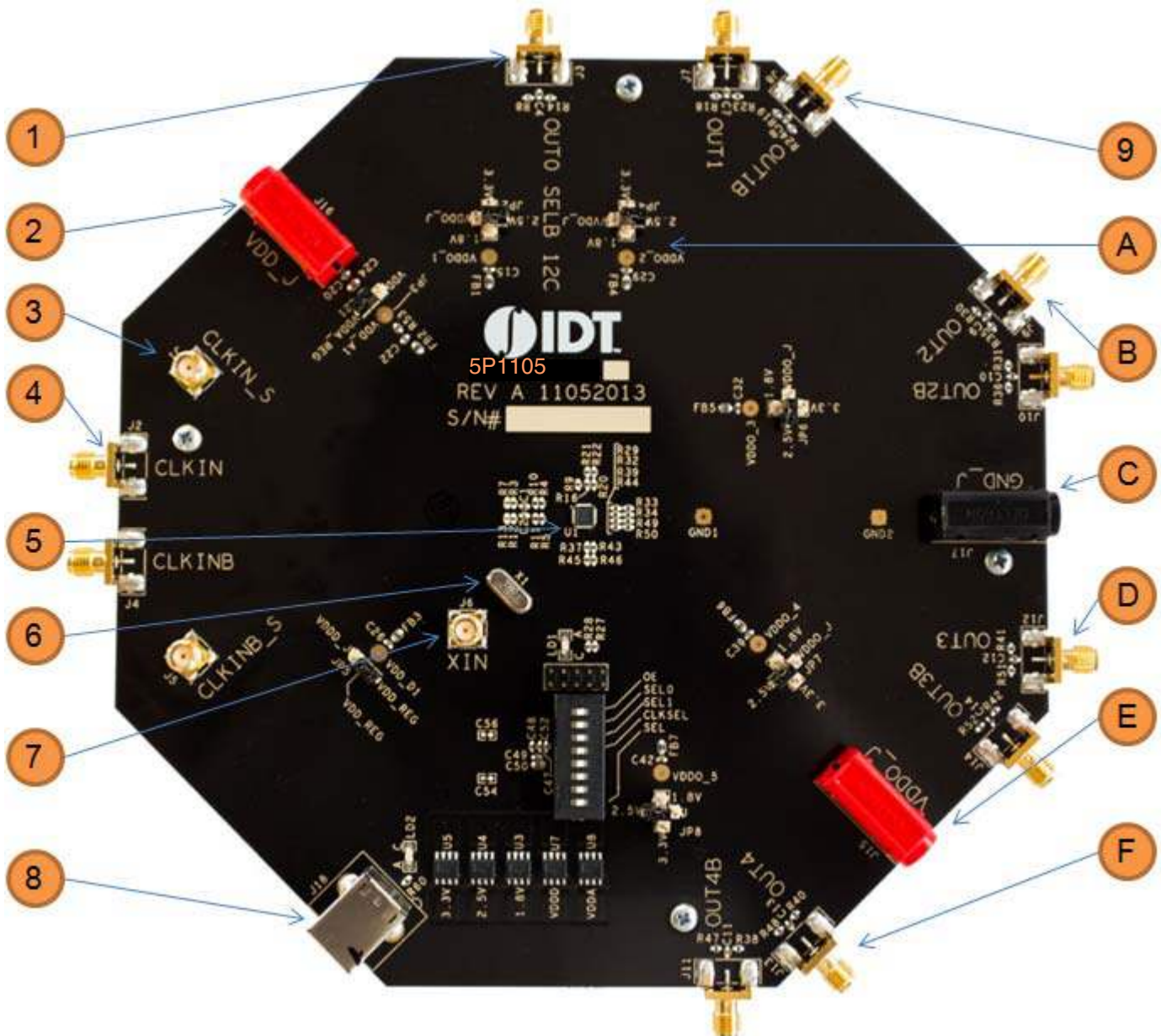

- 1 OUT0 - This is a buffered output of the input reference clock, singled ended.
- 2 Power supply jack, J16 – Connect to 3.3V, 2.5V or 1.8V for the core voltage of the device.
- 3 CLKIN\_S/CLKINB\_S – SMA pair used to monitor the differential input CLKIN/CLKINB.
- 4 Differential Input clock connector – A differential clock can be connected as a source for the device.
- 5 5P1105/5P1103 – the device to be evaluated.
- 6 Crystal – On-board crystal, 25MHz. There are two package holders for crystals: one through-hole and a surface-mount (3225) on the bottom layer of the board.
- 7 XIN connector – This SMA connector is for single-ended clock input. Please note the full swing of this input is 1.2V maximum.
- 8 USB connector – Used this connector to connect with your PC to run IDT Timing Commander Software.
- 9 OUT1 /OUT1B – Output 1. It can be a differential pair or two individual single-ended outputs. Default termination configurations are described in Table 1&2 below.
- A Output voltage selector – 4-way header to select an output voltage. The center pin is the output voltage. Use the jumper to select from 1.8V, 2.5V or 3.3V. VDDO\_J is the voltage from J15 (see E).
- B OUT2/OUT2B – Output 2. It can be a differential pair or two individual single-ended outputs. Default termination configurations are described in Table 1&2 below.
- C Ground Jack – J17. If J15 and/or J16 is used for power supply, this jack is the power return.
- D OUT3/OUT3B – Output 3. It can be a differential pair or two individual single-ended outputs. Default termination configurations are described in Table 1&2 below. (This output is not present on the 5P1103 EVB.)
- E Output Voltage Jack – J15. Connect to a voltage of 1.8V, 2.5V or 3.3V for output voltages.
- F OUT4/OUT4B – Output 4. It can be a differential pair or two individual single-ended outputs. Default termination configurations are described in Table 1&2 below. (This output is not present on the 5P1103 EVB.)

## Board Power Supply

### • Core Voltages

The core voltage includes a digital voltage VDDD and an analog voltage VDDA. Both core voltages can be powered by an external bench power supply or by USB.

**Bench Power Supply** – To supply VDDD with a bench power supply, connect power to J16. To supply VDDA with a bench power supply, connect power to J15. In the same time, place the jumpers in JP3 and JP5 to connect VDDA\_J and VDDD\_J, respectively.

**USB Power Supply** – When the board is connected to a PC through a USB cable, on-board voltage regulators will generate a 3.3V for the device. In this case, place the jumpers in JP3 and JP5 to connect VDDA\_REG and VDDD\_REG, respectively. See JP5 jumper position for VDDD\_REG in the following figure. USB power source is recommended because it's readily available right from your laptop.

**Figure 2. Jumping to the VDDD\_J side will select external bench power supply; Jumping to the VDD\_REG side will select power source from on-board regulators powered by USB**

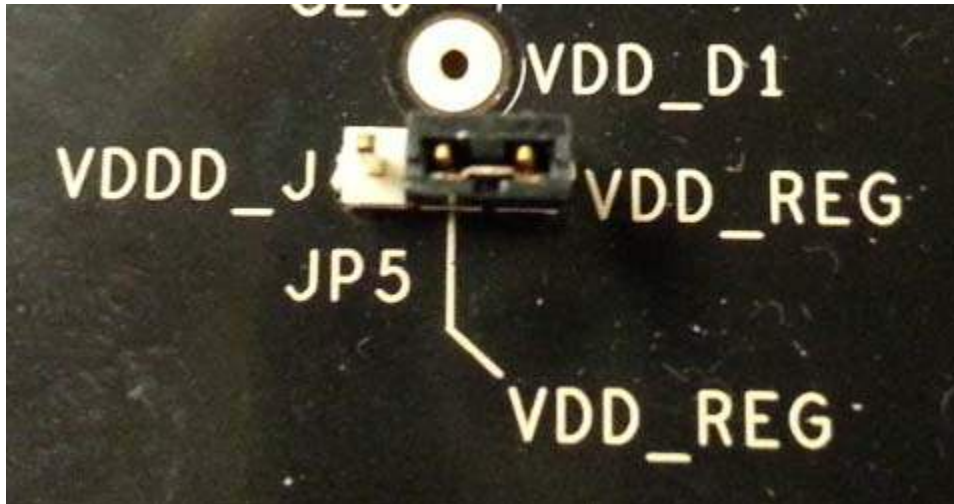

**• Output Clock Voltages**

Like VDDA and VDDD having two sources, each output voltage VDDO0~4 is also provided with two sources to choose from: bench power supply or powered from USB. The selection is made by a 4-way header as shown in Figure 3 below. Jumping to VDDO\_J will select external power supply (JP15 and JP16 are connected to external power supply); Jumping to 1.8V, 2.5V or 3.3V will select each respective voltage from on-board voltage regulators powered by USB port.

**Please note:** each output voltage can be individually selected. Use the label on the evaluation board: VDDO\_1 for OUT0, VDDO\_2 for OUT1, VDDO\_3 for OUT2, VDDO\_4 for OUT3 and VDDO\_5 for OUT4.

**Figure 3. Use the jumper to select a voltage for OUT3: 1.8V/2.5V/3.3V is from on-board voltage regulators powered by USB; VDDO\_J is from external power supply connecting to JP15 and JP16**

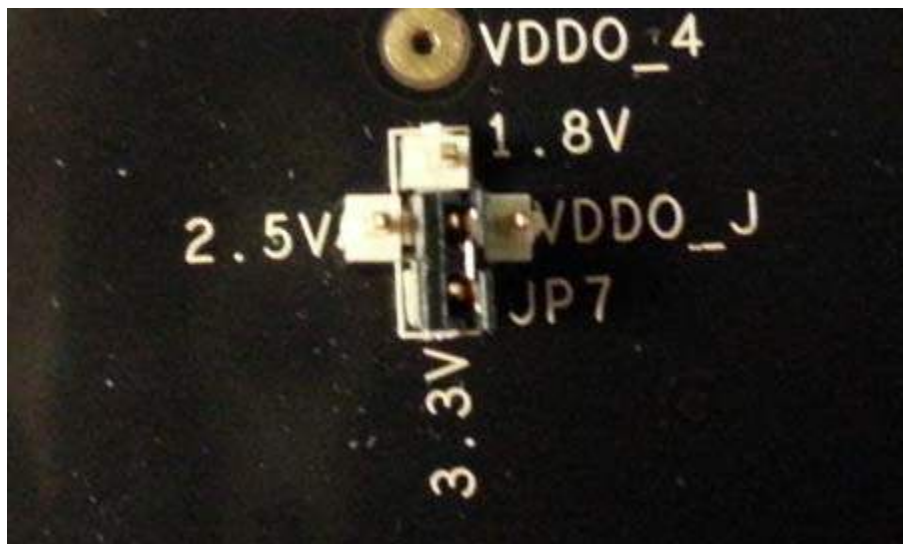

## Connecting the Board

The board is connected to a PC through a USB connector for configuring and programming the device, as shown in Figure 4 below. The USB interface will also provide +5V power supply to the board, from which on-board voltage regulators generate various voltages for the core as well as for each output.

The board can also be powered by a bench power supply by connecting two banana jacks J15, J16 for output and core voltages, respectively. Please see board power supply section for details.

**Note:** The USB port only supports USB 2.0; USB 3.0 is not supported at this time.

**Figure 4. Connecting the Board with USB Port for Communications with Timing Commander Software**

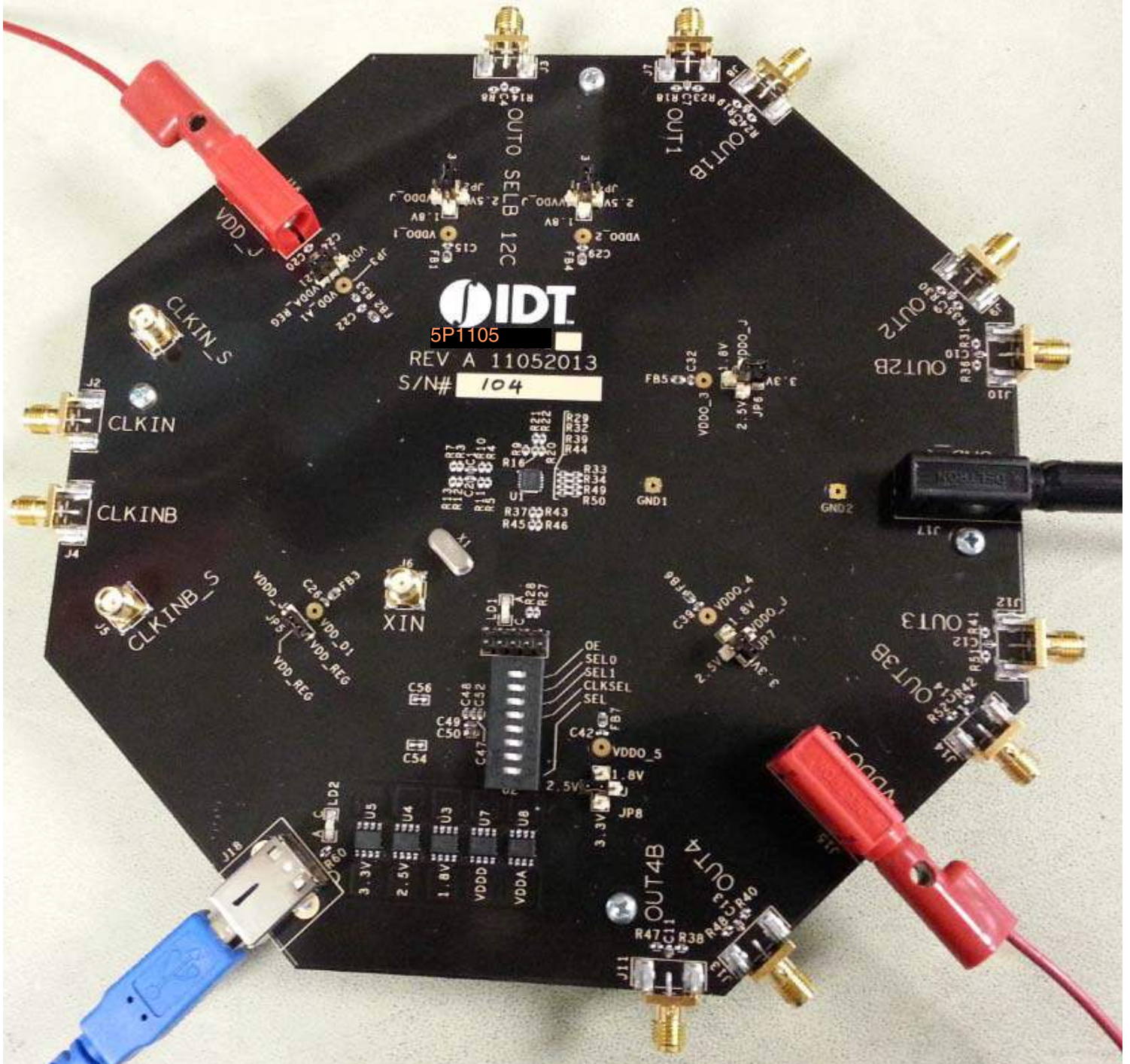

## On-Board Crystal

A 25MHz crystal is installed on the board. It can source a reference frequency to the device when CLKIN/CLKINB is not used. The device can reference from either the crystal or an external clock source. Clock source can be selected within GUI software.

Other input reference can be supplied to CLKIN/CLKINB (differential) or XIN (LVCMOS with full swing of 1.2V) connectors.

## Board Default Frequency Output

When 25MHz crystal is installed, the device will have two default outputs: OUT0 = 25MHz, OUT1 = 100MHz.

## Configuration and Setup

Use the following steps to setup the board using I<sup>2</sup>C and start the configuration of the board.

1. Set SEL pin (pin 8) of dip switch (U2) to "0" to select I2C mode.
2. Connect J18 to a USB port of the PC using the supplied I2C cable.
3. Power up the board.
4. Launch Timing Commander with buffer personality (refer to Programmable Clock Buffer Timing Commander User Guide.). Following the Getting Started steps in the Timing Commander software, an I<sup>2</sup>C connection is established between the GUI software and the programmable clock buffer chip.
5. Load the setting file into the GUI and write the settings to the chip.
6. All intended outputs should be available for measurement.

## Board Schematics

Evaluation board schematics are shown on the following pages.



Figure 6. Evaluation Board Schematic – Page 2

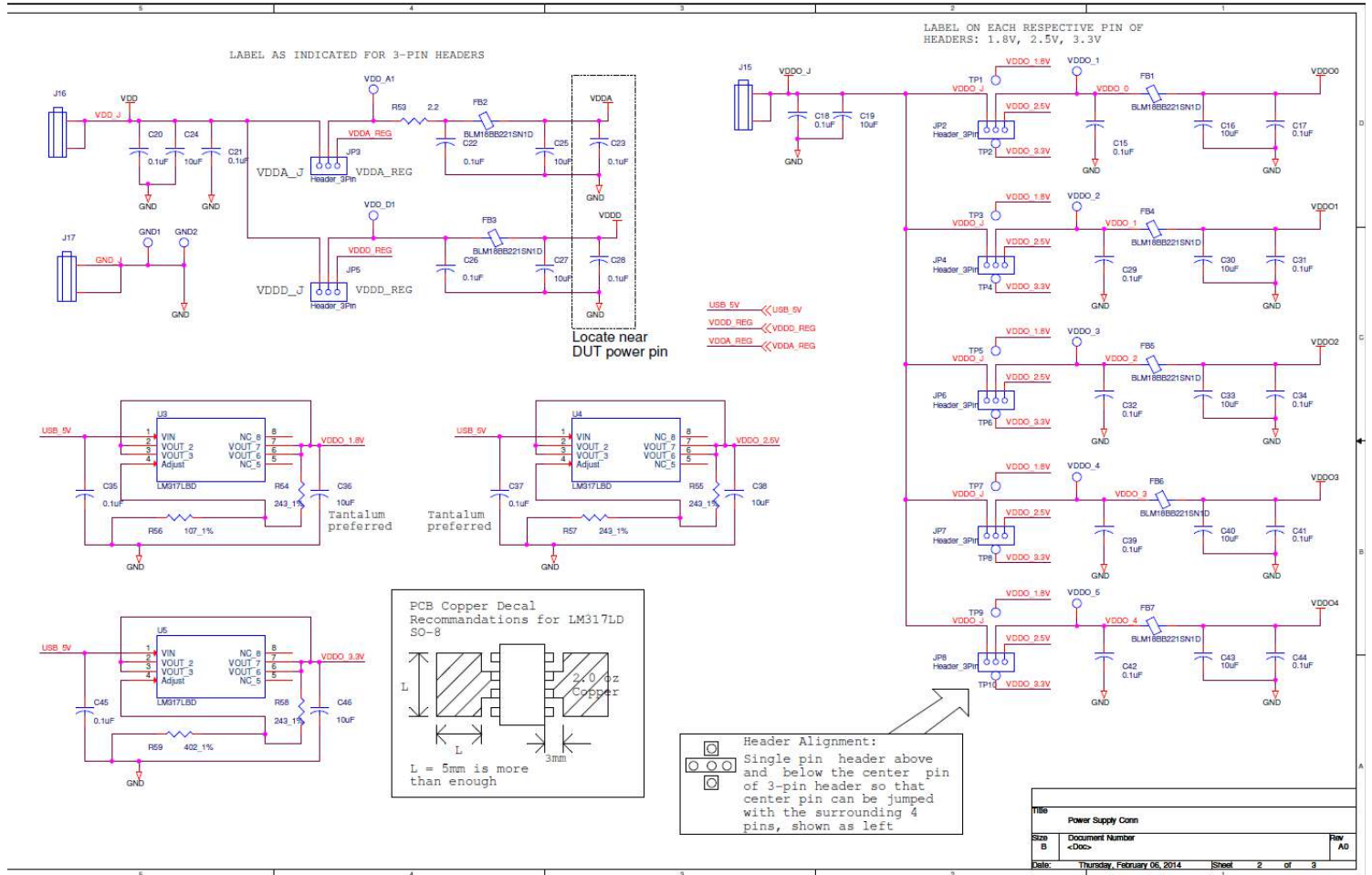
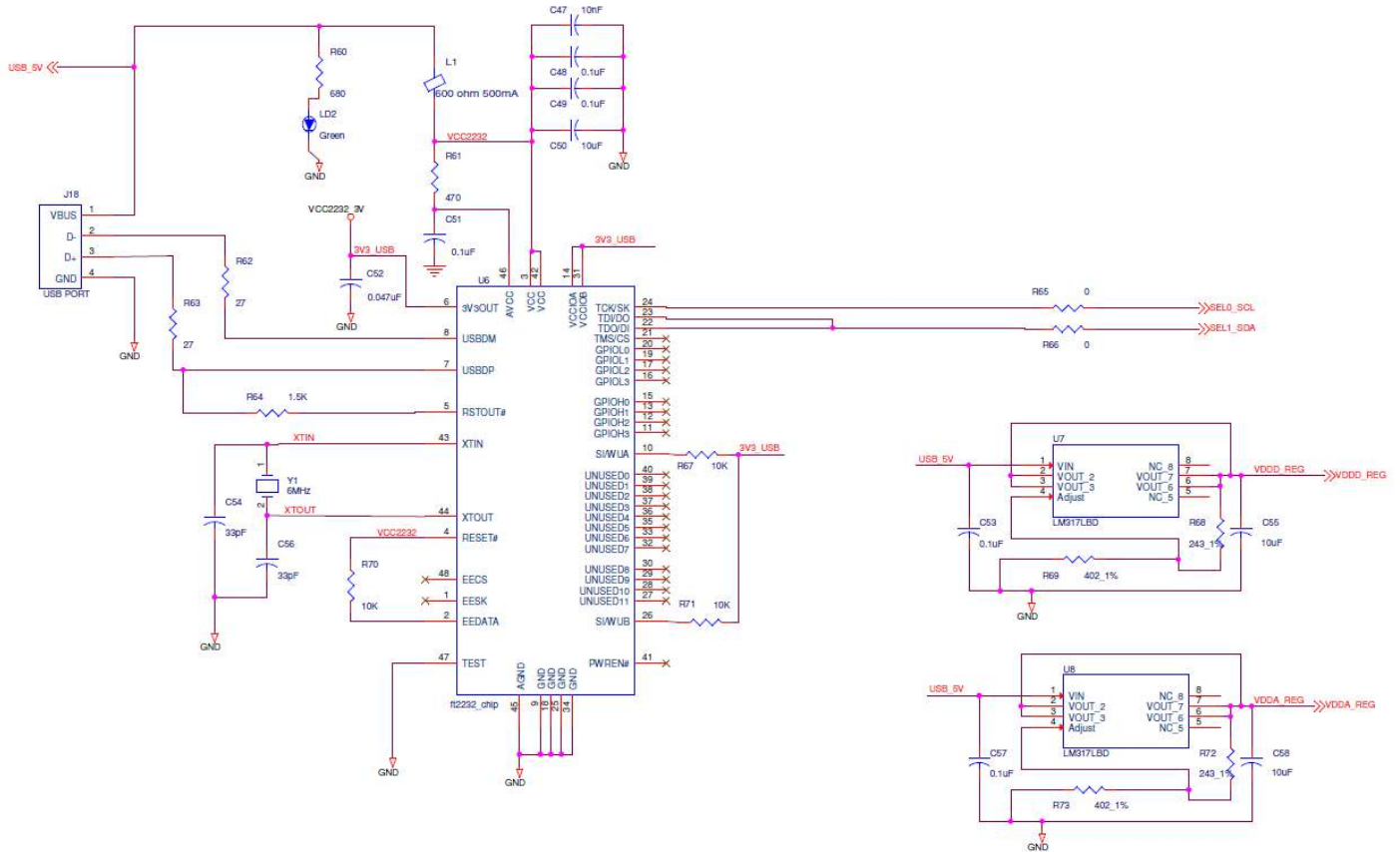

Figure 7. Evaluation Board Schematic – Page 3



Title		
I2C Interface		
Size	Document Number	Rev
B	<Doc>	A0
Date:	Thursday, February 06, 2014	Sheet 9 of 9



## Signal Termination Options

Termination options for OUTPUT1 – 4 in the evaluation board are displayed in Figure 8. The termination circuits are designed to optionally terminate the output clocks in LVPECL, LVDS, LVCMOS and HCSL signal types by populating (or not-populating) some resistors. DC or AC coupling of these outputs are also supported.

Tables 1 and 2, below, tabulates component installations of 5PB1103 and 5PB1105 evaluation boards, to support LVPECL, HCSL, LVCMOS and LVDS signal types for OUTPUT1– 4, respectively. Please note that by doing so, the output signals will be measured and terminated by an oscilloscope with a 50Ω internal termination.

**Figure 8. Output Termination Options**

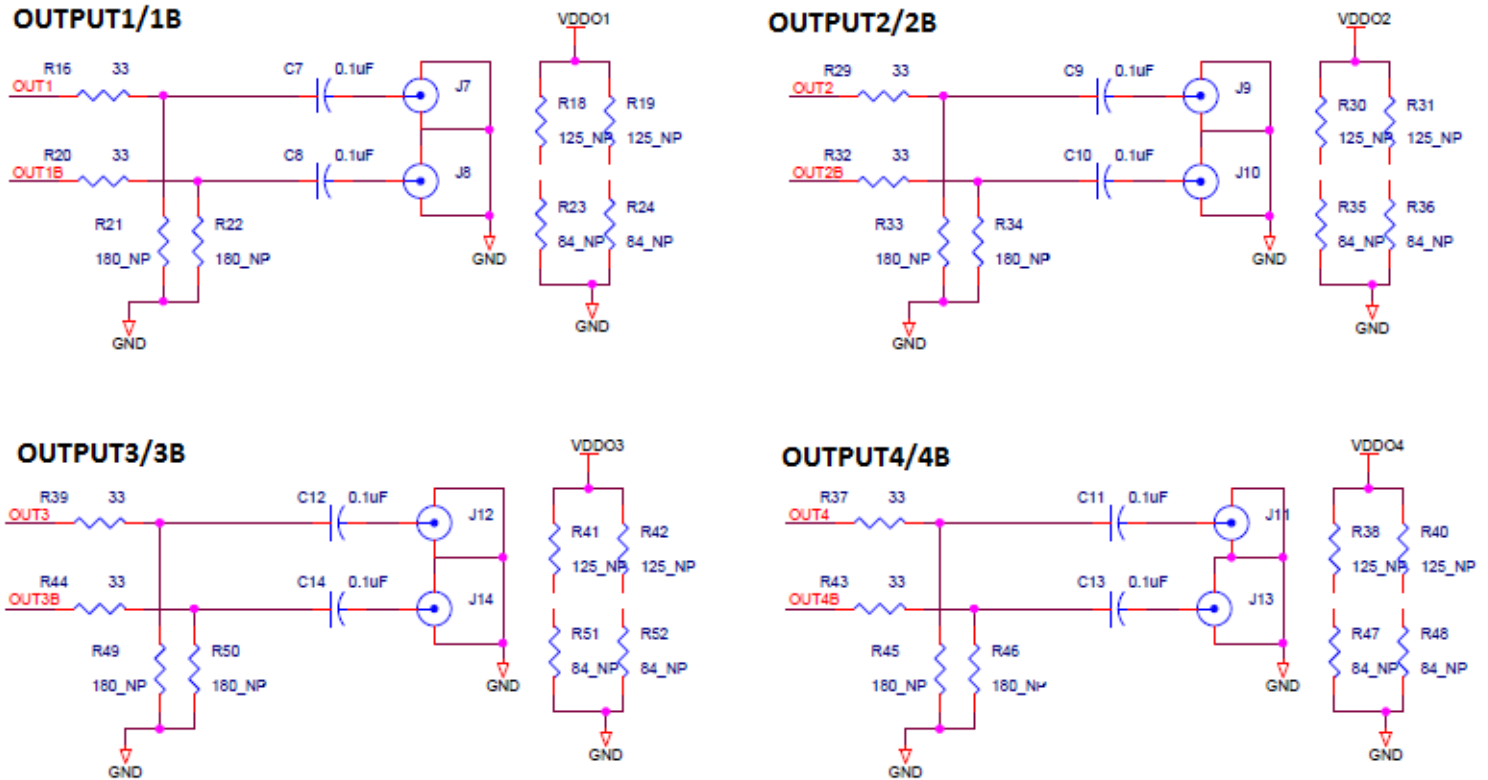

**Table 1. 5PB1103 EVB Output Terminations**

Output Number	Signal Type	Series Resistors	180-ohm pull-down	Series Capacitor	Resistor Network
OUTPUT1	LVPECL	R16=R20=0 Ω	R21, R22 installed	C7=C8=0.1 μF	R18, R19, R23, R24 not installed
OUTPUT2	LVDS	R29=R32=0 Ω	R33, R34 not installed	C9=C10=0.1 μF	R30, R31, R35, R36 not installed

**Table 2. 5PB1105 EVB Output Terminations**

Output Number	Signal Type	Series Resistors	180-ohm pull-down	Series Capacitor	Resistor Network
OUTPUT1	HCSL	R16=R20=33 $\Omega$	R21, R22 not installed	C7=C8=0 $\mu$ F	R18, R19, R23, R24 not installed
OUTPUT2	LVDS	R29=R32=0 $\Omega$	R33, R34 not installed	C9=C10=0.1 $\mu$ F	R30, R31, R35, R36 not installed
OUTPUT3	LVPECL	R39=R44=0 $\Omega$	R49, R50 installed	C12=C14=0.1 $\mu$ F	R41, R42, R51, R52 not installed
OUTPUT4	LVC MOS	R37=R43=33 $\Omega$	R45, R46 not installed	C11=C13=0.1 $\mu$ F	R38, R40, R47, R48 not installed

**Note:** As noted, 4-resistor network is not installed in Table 1 because oscilloscope with internal 50 $\Omega$  termination is utilized for signal termination and measurement. If an AC-coupled, stand-alone LVPECL output is needed (without oscilloscope connections), the 4-resistor network needs to be installed accordingly. The OUTPUT3 and OUTPUT4 are not installed on the 5P1103 EVB.

### Orderable Part Numbers

The following evaluation board part numbers are available for order.

**Table 3. Orderable Part Numbers**

Part Number	Description
EVK-5P1103ALL	Evaluation board for 5P1103. Output termination configurations are as described in Table 1.
EVK-5P1105ALL	Evaluation board for 5P1105. Output termination configurations are as described in Table 2.



## IMPORTANT NOTICE AND DISCLAIMER

RENESAS ELECTRONICS CORPORATION AND ITS SUBSIDIARIES (“RENESAS”) PROVIDES TECHNICAL SPECIFICATIONS AND RELIABILITY DATA (INCLUDING DATASHEETS), DESIGN RESOURCES (INCLUDING REFERENCE DESIGNS), APPLICATION OR OTHER DESIGN ADVICE, WEB TOOLS, SAFETY INFORMATION, AND OTHER RESOURCES “AS IS” AND WITH ALL FAULTS, AND DISCLAIMS ALL WARRANTIES, EXPRESS OR IMPLIED, INCLUDING, WITHOUT LIMITATION, ANY IMPLIED WARRANTIES OF MERCHANTABILITY, FITNESS FOR A PARTICULAR PURPOSE, OR NON-INFRINGEMENT OF THIRD PARTY INTELLECTUAL PROPERTY RIGHTS.

These resources are intended for developers skilled in the art designing with Renesas products. You are solely responsible for (1) selecting the appropriate products for your application, (2) designing, validating, and testing your application, and (3) ensuring your application meets applicable standards, and any other safety, security, or other requirements. These resources are subject to change without notice. Renesas grants you permission to use these resources only for development of an application that uses Renesas products. Other reproduction or use of these resources is strictly prohibited. No license is granted to any other Renesas intellectual property or to any third party intellectual property. Renesas disclaims responsibility for, and you will fully indemnify Renesas and its representatives against, any claims, damages, costs, losses, or liabilities arising out of your use of these resources. Renesas' products are provided only subject to Renesas' Terms and Conditions of Sale or other applicable terms agreed to in writing. No use of any Renesas resources expands or otherwise alters any applicable warranties or warranty disclaimers for these products.

(Disclaimer Rev.1.0 Mar 2020)

### Corporate Headquarters

TOYOSU FORESIA, 3-2-24 Toyosu,  
Koto-ku, Tokyo 135-0061, Japan  
[www.renesas.com](http://www.renesas.com)

### Contact Information

For further information on a product, technology, the most up-to-date version of a document, or your nearest sales office, please visit:  
[www.renesas.com/contact/](http://www.renesas.com/contact/)

### Trademarks

Renesas and the Renesas logo are trademarks of Renesas Electronics Corporation. All trademarks and registered trademarks are the property of their respective owners.